



Leading Conversion Technology for Power Resilience

# INVIEW

Firmware 7.0

## User Manual

### INVIEW MONITORING & CONTROL DEVICES:

- Manages your Infrastructure
- Informs the user in case of Issues
- Minimises Maintenance Expenditures
- Leverages the possibilities of IoT & Big Data
- Allows to save on your electricity bill with Energy Management



### CONTROLLERS FOR BRAVO AND SIERRA MODULES

- Inview Slot
- Inview S
- Inview X & X+
- Inview XC



Copyright ©2026. Construction électroniques & telecommunications S.A.  
All rights reserved. The contents in document are subject to change without notice.  
The products presented are protected by several international patents and trademarks.  
Address: CE+T S.a, Rue du Charbonnage 12, B 4020 Wandre, Belgium  
www.cet-power.com - info@cet-power.com

Version 3.2



# Table of Contents

|                                                      |    |
|------------------------------------------------------|----|
| 1. CE+T Power at a glance.....                       | 7  |
| 2. Abbreviations .....                               | 8  |
| 3. Warranty and Safety Conditions .....              | 9  |
| 3.1 Disclaimer .....                                 | 9  |
| 3.2 Technical care .....                             | 9  |
| 3.3 Installation .....                               | 10 |
| 3.3.1 Handling.....                                  | 10 |
| 3.3.2 Surge and transients .....                     | 10 |
| 3.3.3 Other.....                                     | 10 |
| 3.4 Maintenance .....                                | 11 |
| 3.5 Replacement and Dismantling.....                 | 11 |
| 4. Introduction .....                                | 12 |
| 4.1 Inview Slot .....                                | 12 |
| 4.2 Inview S .....                                   | 12 |
| 4.3 Inview X and X+ .....                            | 13 |
| 4.4 Inview XC.....                                   | 13 |
| 4.5 Inview Widget Page.....                          | 14 |
| 4.6 Inview Slot, S, X, X+ & XC - Specifications..... | 15 |
| 4.7 Inview License .....                             | 16 |
| 4.8 Accessories.....                                 | 18 |
| 4.8.1 MBB (Measure Box Battery).....                 | 18 |
| 4.8.2 Measure Box Battery Specifications.....        | 19 |
| 5. Installation .....                                | 20 |
| 5.1 Site preparation.....                            | 20 |
| 5.2 Installing - Inview Slot .....                   | 20 |
| 5.3 Mounting - Inview S .....                        | 20 |
| 5.3.1 Panel Mounting .....                           | 20 |
| 5.3.2 Din-rail Mounting .....                        | 21 |
| 5.4 Mounting - Inview X / X+.....                    | 22 |
| 5.5 Installing - Inview XC.....                      | 23 |
| 5.5.1 Wall mounting .....                            | 23 |
| 5.5.2 Pole mounting .....                            | 23 |
| 5.5.3 Panel mounting .....                           | 23 |
| 5.6 Hardware Connections .....                       | 23 |
| 5.6.1 Inview Slot - Connections .....                | 24 |
| 5.6.2 Inview S - Connections.....                    | 25 |
| 5.6.3 Inview X / X+ - Connections .....              | 25 |
| 5.6.4 Inview XC - Connections.....                   | 26 |
| 5.6.5 MBB (Measure Box Battery) - Connections .....  | 27 |
| 5.6.6 Output Relay Connections.....                  | 28 |

|           |                                                        |           |
|-----------|--------------------------------------------------------|-----------|
| 5.6.7     | Digital Input Connections.....                         | 28        |
| 5.6.8     | CAN / ModBus (RS485) Pin Details .....                 | 29        |
| 5.6.9     | Inview Slot with Bravo 10 and Sierra 10 - System ..... | 29        |
| 5.6.10    | Inview S with Bravo and Sierra - System .....          | 30        |
| 5.6.11    | Inview X / X+ with Bravo and Sierra - System.....      | 30        |
| 5.6.12    | Inview XC with Sierra XC - System .....                | 31        |
| <b>6.</b> | <b>Overview - Web Interface.....</b>                   | <b>32</b> |
| 6.1       | Interface .....                                        | 33        |
| 6.1.1     | INVIEW Display Option .....                            | 33        |
| 6.1.2     | Home Page.....                                         | 34        |
| 6.1.3     | Widgets.....                                           | 35        |
| 6.2       | Web page Controls .....                                | 36        |
| <b>7.</b> | <b>Power System Settings .....</b>                     | <b>38</b> |
| 7.1       | Login.....                                             | 38        |
| 7.2       | Users Management .....                                 | 38        |
| 7.2.1     | Web Interface - User account .....                     | 39        |
| 7.2.2     | LCD Interface - PIN number.....                        | 39        |
| 7.3       | Site Management .....                                  | 40        |
| 7.3.1     | Site Description.....                                  | 40        |
| 7.3.2     | Date and Time Settings .....                           | 40        |
| 7.3.3     | Network Settings.....                                  | 41        |
| 7.4       | System Configuration .....                             | 41        |
| 7.4.1     | Topology Selection .....                               | 42        |
| 7.4.2     | Fallback mode.....                                     | 43        |
| 7.4.3     | Phase Selection .....                                  | 44        |
| 7.4.4     | AC Output Configuration .....                          | 44        |
| 7.4.5     | Converters Configuration .....                         | 45        |
| 7.4.6     | DC Configuration .....                                 | 46        |
| 7.5       | Battery Configuration .....                            | 47        |
| 7.5.1     | Measurement Source .....                               | 48        |
| 7.5.2     | Battery Disconnect or LVD .....                        | 48        |
| 7.6       | Sensors and Actuators.....                             | 49        |
| 7.6.1     | MBB Configuration .....                                | 50        |
| 7.7       | Manual Bypass Configuration .....                      | 53        |
| 7.8       | Module Remote ON/OFF .....                             | 53        |
| 7.9       | Widgets Configuration .....                            | 55        |
| 7.10      | Communication Protocol.....                            | 58        |
| 7.10.1    | Modbus.....                                            | 58        |
| 7.10.2    | SNMP.....                                              | 63        |
| 7.10.3    | MIB .....                                              | 64        |
| 7.11      | Cyber Security.....                                    | 64        |
| 7.11.1    | Password Policy .....                                  | 64        |
| 7.11.2    | Weak Password Alarm.....                               | 64        |
| 7.11.3    | Password Protection.....                               | 65        |

|                                                                                      |           |
|--------------------------------------------------------------------------------------|-----------|
| 7.11.4 Software Downgrade and Reset .....                                            | 65        |
| <b>8. Overview - LCD Interface .....</b>                                             | <b>66</b> |
| 8.1 Inview Slot - LCD Display .....                                                  | 66        |
| 8.1.1 LED Indications .....                                                          | 66        |
| 8.1.2 Menu Structure .....                                                           | 67        |
| 8.2 Inview S - LCD Interface .....                                                   | 68        |
| 8.2.1 LED Indications .....                                                          | 68        |
| 8.2.2 Menu Structure .....                                                           | 69        |
| 8.3 Inview X / X+ - LCD Interface .....                                              | 70        |
| 8.3.1 Menu Structure .....                                                           | 71        |
| 8.3.2 LED Indications .....                                                          | 72        |
| 8.4 Inview XC - LED Indications .....                                                | 72        |
| 8.5 LCD Interface - Terminology .....                                                | 72        |
| <b>9. Defective Unit .....</b>                                                       | <b>73</b> |
| 9.1 Return Defective Inview .....                                                    | 73        |
| <b>10. Troubleshooting and Service .....</b>                                         | <b>74</b> |
| <b>11. Annexe 1: Converter - Parameter List.....</b>                                 | <b>75</b> |
| <b>12. Annexe 2: PLC/Boolean Expression .....</b>                                    | <b>76</b> |
| 12.1 Overview .....                                                                  | 76        |
| 12.2 Abbreviations used in the Syntax .....                                          | 76        |
| 12.3 Use of Syntax to Access Data Entries from a Monitored Device .....              | 77        |
| 12.4 Use of Syntax to Access Alarms Grouped by Severity Level or Severity Type ..... | 77        |
| 12.5 Operators and Functions .....                                                   | 78        |
| 12.6 Examples of Boolean Expressions for Custom PLC Data, Alarms and Relays .....    | 79        |
| 12.6.1 Create Custom Data .....                                                      | 79        |
| 12.6.2 Create Custom Alarm .....                                                     | 80        |
| 12.6.3 Create Custom Relay .....                                                     | 83        |
| 12.6.4 Simple Examples of Custom Alarms or Data .....                                | 86        |
| <b>13. Annexe 3: Inview - Software Upgrade.....</b>                                  | <b>87</b> |
| <b>14. Annexe 4: Hardware Replacement.....</b>                                       | <b>89</b> |
| 14.1 Inview Slot, S, X, X+ and XC .....                                              | 89        |
| 14.2 Accessories - MBB 60V / MBB 500V.....                                           | 90        |
| <b>15. Annexe 5: Wiring Diagrams .....</b>                                           | <b>91</b> |
| 15.1 Inview Slot with MBB.....                                                       | 91        |
| 15.2 Inview S with MBB .....                                                         | 92        |
| 15.3 Inview X / X+ with MBB.....                                                     | 93        |
| 15.4 Inview XC with MBB .....                                                        | 94        |
| <b>16. Annexe 6: Auxiliary power supply kit .....</b>                                | <b>95</b> |
| 16.1 Auxiliary power supply kit with Din Rail .....                                  | 95        |
| 16.2 Auxiliary power supply kit - Wiring diagram.....                                | 95        |

---

|                                        |    |
|----------------------------------------|----|
| 17. Annexe 7: Inview Panel Sheets..... | 96 |
| 17.1 Inview S - Panel Sheets.....      | 96 |
| 17.2 Inview X / X+ - Panel Sheet.....  | 97 |
| 17.3 Inview XC - Dimensions.....       | 97 |

## Release Note

| Version | Release date (DD/MM/YYYY) | Modified page number      | Modifications                                                                                                                              |
|---------|---------------------------|---------------------------|--------------------------------------------------------------------------------------------------------------------------------------------|
| 1.0     | 23/04/2021                | -                         | First release of the manual                                                                                                                |
| 1.1     | 27/08/2021                | 38                        | Added Remote ON/OFF details                                                                                                                |
|         |                           | 58 - 59                   | Added boolean expressions                                                                                                                  |
| 1.2     | 28/09/2021                | 17 & 19                   | Updated auxiliary power supply kit part number                                                                                             |
| 1.3     | 16/11/2022                | 13, 16 & 21               | Added License Options, Din-rail mounting procedure and RS485 details                                                                       |
| 1.4     | 16/12/2022                | 44                        | Added new password policy details                                                                                                          |
| 1.5     | 14/02/2023                | 55 - 63                   | Updated section the Annexe 1: Converter - Parameter List                                                                                   |
| 2.0     | 14/09/2023                | -                         | Updated the manual to Firmware version 6                                                                                                   |
| 2.1     | 28/02/2024                | -                         | Added Inview XC details                                                                                                                    |
| 2.2     | 06/06/2024                | 28                        | Updated the Sierra XC with Inview XC connections                                                                                           |
| 2.3     | 14/08/2024                | 71-82                     | Updated the PLC/Boolean expression details                                                                                                 |
| 2.4     | 28/04/2025                | -                         | Removed UMB details, added MB500 and Inview X+ details                                                                                     |
| 2.5     | 16/05/2025                | 16                        | Updated the Inview License details                                                                                                         |
| 3.0     | 16/12/2025                | -                         | Updated Inview 7.0 web UI and HMI                                                                                                          |
| 3.1     | 12/03/2026                | 100, 29,<br>30, 31,<br>15 | Added legal Information to "Disclaimer"<br>Updated measure box battery (MBB) information<br>Updated operating temperature in specification |
| 3.2     | 18/03/2026                | 27                        | Updated Inview XC pin details                                                                                                              |

# 1. CE+T Power at a glance

---

CE+T Power is your trusted partner in **advanced power solutions** engineered to meet the demands of modern and dynamic industrial applications. With over 60 years of experience in power conversion technology, CE+T Power nurtures the industry with **innovative solutions designed for critical power backup and energy management**.

Our complete range of power solutions includes **modular inverters** (DC to AC), UPS (securing AC loads with batteries), and **multi-directional converters** (inverter, rectifier, and UPS all-in-one). Coupled with our state-of-the-art **monitoring solution**, you have a real energy blender to connect multiple sources of energy seamlessly!

Whether you require **robust backup power solutions**, **energy management solutions**, or a **combination of both**, CE+T Power delivers tailored solutions to meet your specific needs. Our products are **designed with integration in mind**, ensuring **seamless compatibility with other components of your system**. CE+T Power is committed to providing you with the expertise and resources needed to maximize the performance of your power systems.

Thank you for choosing CE+T Power as your partner in advanced power management. Let's power the future together.

## 2. Abbreviations

---

|        |                                                          |
|--------|----------------------------------------------------------|
| AC     | Alternating current                                      |
| AL     | Alarm                                                    |
| DC     | Direct current                                           |
| DHCP   | Dynamic Host Configuration Protocol                      |
| DSP    | Digital Signal Processor                                 |
| ECI    | Enhanced Conversion Innovation                           |
| EPC    | Enhanced Power Conversion                                |
| ESD    | Electro Static Discharge                                 |
| ETH    | Ethernet                                                 |
| HTTP   | HyperText Transfer Protocol                              |
| HTTPS  | Secure HyperText Transfer Protocol                       |
| LAN    | Local Access Network                                     |
| LVD    | Low Voltage Disconnect                                   |
| MBB    | Measure Box Battery                                      |
| MBP    | Manual By-pass                                           |
| MET    | Main Earth Terminal                                      |
| MIB    | Management Information Base                              |
| N      | Neutral                                                  |
| NTP    | Network Time Protocol                                    |
| NT/KO  | Not Okay                                                 |
| NUA    | Non-Urgent Alarm                                         |
| PCB    | Printed Circuit Board                                    |
| PE     | Protective Earth (also called Main Protective Conductor) |
| PEK    | Power Extension Kit                                      |
| PWR    | Power                                                    |
| REG    | Regular                                                  |
| SNMP   | Simple Network Management Protocol                       |
| TCP/IP | Transmission Control Protocol/Internet Protocol          |
| TRS    | True Redundant Structure                                 |
| UA     | Urgent Alarm                                             |
| USB    | Universal Serial Bus                                     |

## 3. Warranty and Safety Conditions\*

### WARNING:

Except Inview XC, the electronics in the power supply system are designed for an indoor, clean environment.

When installed in a dusty and/or corrosive environment, outdoor or indoor, it is important to:

- Install an appropriate filter on the enclosure door, or on the room's air conditioning system.
- Keep the enclosure door closed during operation.
- Replace the filters on a regular basis.

**Important safety instructions, save these instructions.**

### 3.1 Disclaimer

- The manufacturer declines all responsibilities if equipment is not installed, used or operated according to the instructions herein by skilled technicians according to local regulations.
- Warranty does not apply if the product is not installed, used and handled according to the instructions in the manuals.

### 3.2 Technical care

- This electric equipment can only be repaired or maintained by a “qualified employee” with adequate training. Even personnel who are in charge of simple repairs or maintenance are required to have knowledge or experience related to product maintenance.
- Please follow the procedures contained in this Manual, and note all the “DANGER”, “WARNING” AND “NOTICE” marks contained in this Manual. Warning labels must not be removed.
- Qualified employees are trained to recognize and avoid any dangers that might be present when working on or near exposed electrical parts.
- Qualified employees understand how to lock out and tag out machines so the machines will not accidentally be turned on and injure employees working on them.
- Qualified employees also understand safety related work practices, including those by OSHA and NFPA, as well as knowing what personal protective equipment should be worn.
- All operators are to be trained to perform the emergency shut-down procedure.
- Never wear metallic objects such as rings, watches, or bracelets during installation, service and maintenance of the product.
- Insulated tools must be used at all times when working with live systems.
- When handling the system/units pay attention to sharp edges.

---

\* These instructions are valid for most CE+T Products/Systems. Some points might however not be valid for the product described in this manual.

### 3.3 Installation

- This product is intended to be installed only in restricted access areas.
- The Inverter System may contain output over current protection in the form of circuit breakers. In addition to these circuit breakers, the user must observe the recommended upstream and downstream circuit breaker requirements as per the local regulations.
- Please use extreme caution when accessing circuits that may be at hazardous voltages or energy levels.
- The modular inverter rack is a dual input power supply. The complete system shall be wired in a way that both input and output leads can be made power free.
- In REG systems, to comply with local and international safety standards the N (output) and PE shall be bonded. The bonded connection between N (output) and PE must be removed once the AC input is connected.
- AC and DC circuits shall be terminated with no voltage / power applied.
- The safety standard IEC/EN62040-1-1 requires that, in the event of an output short circuit, the inverter must disconnect in 5 seconds maximum. The parameter can be adjusted on Inview controller; however, if the parameter is set at a value > 5 seconds, an external protection must be provided so that the short circuit protection operates within 5 seconds. Default setting is 60 seconds.
- The system is designed for installation within an IP20 or IP21 environment. When installed in a dusty or humid environment, appropriate measures (air filtering) must be taken.
- All illustrations in the manual are for general reference.

#### 3.3.1 Handling

- The cabinet shall not be lifted using lifting eyes.
- Remove weight from the cabinet by unplugging the inverters. Mark inverters clearly with shelf and position for correct rebuild. This is especially important in dual or three phase configurations.
- Empty module positions must not be left open. Replace with dummy cover.

#### 3.3.2 Surge and transients

The mains (AC) supply of the modular inverter system shall be fitted with Lightning surge suppression and Transient voltage surge suppression suitable for the application at hand. Manufacturer's recommendations of installation shall be adhered to. Selecting a device with an alarm relay for function failure is advised.

Indoor sites are considered to have a working lightning surge suppression device in service.

- Indoor sites Min Class II.
- Outdoor sites Min Class I + Class II or combined Class I+II. The modular inverter system/rack can reach hazardous leakage currents. Earthing must be carried out prior to energizing the system. Earthing shall be made according to local regulations.

#### 3.3.3 Other

- Isolation test (Hi-Pot) must not be performed without instructions from the manufacturer.

### 3.4 Maintenance

- The converter system/rack can reach hazardous leakage currents. Earthing must be carried out prior to energizing the system. Earthing shall be made according to local regulations.
- Prior to any work conducted to a system/unit, make sure that AC input voltage and DC input voltage are disconnected.
- Prior to accessing the system or modules, make sure all source of supply is disconnected.
- **CAUTION** – Risk of electric shock. Capacitors store hazardous energy. Do not remove cover until five minutes after disconnecting all sources of supply.
- Some components and terminals carry high voltage during operation. Contact may result in fatal injury.

### 3.5 Replacement and Dismantling

- ESD Strap must be worn when handling PCBs and open units.
- CE+T cannot be held responsible for disposal of the Inverter system and therefore the customer must segregate and dispose of the materials which are potentially harmful to the environment, in accordance with the local regulations in force in the country of installation.
- If the equipment is dismantled, to dispose of its component products, you must comply with the local regulations in force in the country of destination and in any case avoid causing any kind of pollution.

Note: To download the latest documents, please visit our website [www.cet-power.com](http://www.cet-power.com) and to download latest software visit our website [my.cet-power.com](http://my.cet-power.com).

## 4. Introduction

### 4.1 Inview Slot

**Inview Slot** is an advanced monitoring and controller unit for Bravo 10 and Sierra 10 power systems. This product is specially designed in 1U height to accommodate in the converter shelf and reduces the additional space in the cabinet.

The Inview Slot also allows the user to easily access the system information through inbuilt powerful LCD touch screen graphic display. In addition to the touch screen display, the user can also access the system information through the web interface and SNMP protocol.

The Inview Slot interface provides the user to access the configuration and setup files of the modules in the system. Also, it is a controller for DC regulation

Inview Slot can monitor up to 32 inverters/converters and featured with:

- 1.8" LCD touch screen display
- Three LED's to indicate Major alarm, Minor alarm and System status
- Two Digital Inputs
- Two Output Relay contacts
- Records 5000 logs as FIFO



*Inview Slot*

### 4.2 Inview S

**Inview S** is an advanced monitoring and controller unit for Bravo 10, Bravo 25, Sierra 10 and Sierra 25 power systems. It allows the user to easily access the system information through inbuilt powerful touch screen graphic display. In addition to the touch screen display, the user can also access the system information through the web interface and SNMP protocol.

The Inview S interface provides the user to access the configuration and setup files of the modules in the system. Like Inview Slot, it is also a controller for DC regulation.

Inview S can monitor up to 32 inverters/converters and featured with:

- 2.8" LCD touch screen display
- Three LED's to indicate Major alarm, Minor alarm and System status
- Two Digital Inputs
- Two Output Relay contacts
- Records 5000 logs as FIFO



*Inview S*

### 4.3 Inview X and X+

**Inview X / X+** is an advanced monitoring and controller unit for **Bravo 10, Bravo 25, Sierra 10 and Sierra 25** power systems. It allows the user to easily view, access the system information through LCD screen graphic display and web interface. The home screen of both LCD and web interface provides a summary of system power, modules, batteries, and events information.

The Ethernet ports in Inview X / X+ allows multiple communication points for remote communication and Web interface. This additional Ethernet port makes it compulsory to use Inview X / X+ with large systems relying on the Power Extension Kit and also when Inview Gateway is required to manage several kinds of CE+T converters.

The Inview X / X+ comes up with easier access to connect accessories such as Measure Box Battery, Smart Battery BMS and so on. Its interface provides the user access to the configuration and setup files of the modules that are connected in the system. It is also a controller for DC regulation.

Inview X / X+ is featured with the following:

- Monitor up to 32 converters, and with Power Extension Kits, it can monitor up to 270.
- 7" LCD touch screen display with LED strip around the screen to indicate Major alarm, minor alarm and system status.
- Two Digital Inputs and two Output Relay contacts.
- Higher Temperature Resistance
- Records 5000 events as FIFO



*Inview X*



*Inview X+*

### 4.4 Inview XC

**Inview XC** is an advanced monitoring and controller unit especially suited for **Sierra XC** power systems. It allows the user to easily access the system information through the web interface and SNMP protocol.

The Inview XC interface provides the user to access the configuration and setup files of the modules in the system. Like the other Inview interfaces, it is also a controller for DC regulation.

Inview XC is featured with the following:

- Monitors up to 32 converters.
- Three LEDs to indicate Major alarm, Minor alarm and System Status.
- Two Digital Inputs and two Output Relay contacts.
- Higher temperature resistance.



*Inview XC*

## 4.5 Inview Widget Page

The generic view of different Inview (Slot, S, X and X+) displays and their web interface are provided below.

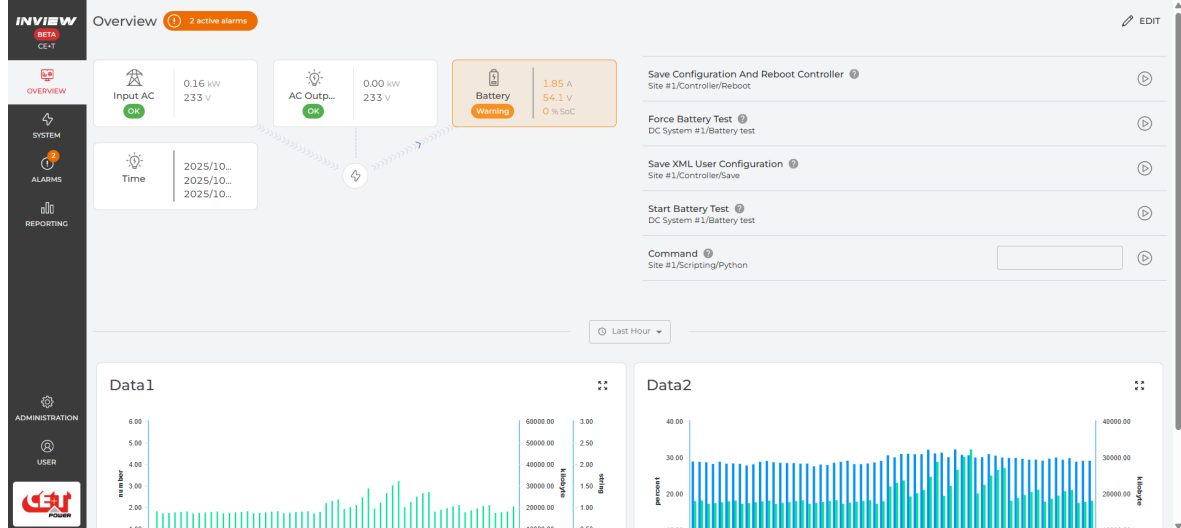

Widget view in web interface

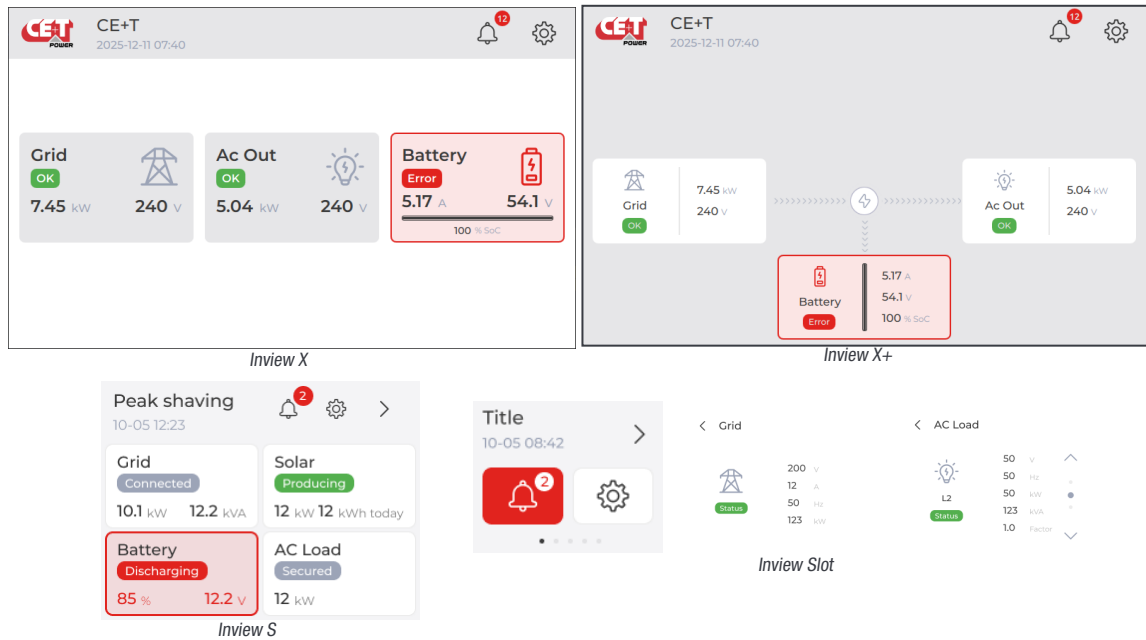

Widget view in LCD touch screen

## 4.6 Inview Slot, S, X, X+ & XC - Specifications

| Models                       | Inview Slot                                                            | Inview S                                      | Inview X                                     | Inview X+                                                      | Inview XC                                               |
|------------------------------|------------------------------------------------------------------------|-----------------------------------------------|----------------------------------------------|----------------------------------------------------------------|---------------------------------------------------------|
| Modules compatibility        | Bravo 10 and Sierra 10                                                 | Bravo 25 and Sierra 25                        |                                              |                                                                | Sierra XC                                               |
| Display                      | 1.8" resistive touchscreen                                             | 2.8" capacitive touchscreen                   | 7" capacitive touchscreen                    |                                                                | No (IP65 protected)                                     |
| Hardware interfaces          | 1 x ETH*,<br>1 x RS485**,<br>1 x CAN, 1 x USB                          | 1 x ETH*,<br>1 x RS485**,<br>1 x CAN, 1 x USB | 3 x ETH*, 1 x RS485**,<br>1 x CAN, 2 x USB   |                                                                | 1 x ETH*, 1 x RS485**,<br>1 x CAN, 1 x 19 Pin connector |
| Supported protocols          | Modbus RS485, Modbus TCP, SNMP v1, v2C and v3, HTTP/HTTPS              |                                               |                                              |                                                                |                                                         |
| Digital Input / Output relay | 2 / 2                                                                  |                                               |                                              |                                                                |                                                         |
| Accessories                  | Measure Box Battery (MBB 60V and 500V)                                 |                                               |                                              |                                                                | Measure Box Battery (MBB) with external power supply    |
| Buzzer                       | Yes                                                                    |                                               |                                              |                                                                | No                                                      |
| Mounting                     | 1U Shelf                                                               | DIN / Panel / Door                            | Panel / Door                                 |                                                                | Pole / Wall / Panel / Door                              |
| Power supply                 | Internal shelf 48 Vdc (40 to 60 Vdc) or External 12 Vdc (10 to 14 Vdc) | External 12 Vdc (10 to 14 Vdc)                | External redundant 2 x 48 Vdc (40 to 60 Vdc) | External redundant 2 x 12 Vdc - 24 Vdc - 48 Vdc (12 to 60 Vdc) | Internal power supply 12 Vdc (from Modules)             |
| Power consumption            | 6 W                                                                    | 5 W                                           | 17 W                                         |                                                                | 5 W                                                     |
| Operating Temperature Range  | -20 to 50°C                                                            | -20 to 50°C                                   | -20 to 65°C                                  |                                                                | -20 to 65°C                                             |
| CPU                          | NXP i.MX 6UltraLite                                                    |                                               |                                              | NXP i.MX 6QuadPlus                                             | NXP i.MX 6UltraLite                                     |
| CPU cores                    | 1 x ARM Cortex A7                                                      |                                               |                                              | 4 x ARM Cortex A9                                              | 1 x ARM Cortex A7                                       |
| CPU frequency                | 528 MHz                                                                |                                               |                                              | 996 MHz                                                        | 528 MHz                                                 |
| Integrated GPU               | No                                                                     |                                               |                                              | Yes                                                            | No                                                      |
| RAM                          | 512 MB                                                                 |                                               |                                              | 1 GB                                                           | 512 MB                                                  |
| eMMC                         | 2 x 4 GB                                                               |                                               |                                              | 2 x 8 GB                                                       | 2 x 4 GB                                                |
| Dimension (WxHxD)            | 87 x 42 x 331 mm                                                       | 180 x 83 x 31 mm                              | 187 x 128 x 54 mm                            |                                                                | 312 x 71 x 155 mm                                       |
| Weight                       | 650 g                                                                  | 240 g                                         | 725 g                                        |                                                                | 2.5 kg                                                  |
| Part number                  | T602004110                                                             | T602004100                                    | T602004200                                   | T602004220                                                     | T602004140                                              |

(\*: 100 Mbps, auto-negotiation), (\*\* : internal termination on Inview)

## 4.7 Inview License

Inview Slot/S/X/X+/XC includes a default standard licence. To upgrade this default licence to any listed licence option. Contact your supplier or CE+T for the latest price.

| License Number | License Type               | Features                                                                                                                                                                                                                                                                                                                                                                                                                                                                                                                                                                                                                                                                                                                                                                                                                                                                                                                                                                                                                                                                                                                                                                                                                                                                                                                                                                                                                                                                                                                                                                                                                                                                         |
|----------------|----------------------------|----------------------------------------------------------------------------------------------------------------------------------------------------------------------------------------------------------------------------------------------------------------------------------------------------------------------------------------------------------------------------------------------------------------------------------------------------------------------------------------------------------------------------------------------------------------------------------------------------------------------------------------------------------------------------------------------------------------------------------------------------------------------------------------------------------------------------------------------------------------------------------------------------------------------------------------------------------------------------------------------------------------------------------------------------------------------------------------------------------------------------------------------------------------------------------------------------------------------------------------------------------------------------------------------------------------------------------------------------------------------------------------------------------------------------------------------------------------------------------------------------------------------------------------------------------------------------------------------------------------------------------------------------------------------------------|
| 1              | Standard (called 'Inview') | <ul style="list-style-type: none"> <li>• Communication with a limited number of CE+T devices: <ul style="list-style-type: none"> <li>▪ Maximum 32 Sierra/Bravo</li> <li>▪ MBB 60V and MBB 500V without limitation</li> </ul> </li> <li>• Real Time Monitoring and Configuration via Web Interface, including relay mapping: <ul style="list-style-type: none"> <li>▪ Access to Inview web interface</li> <li>▪ Alarms reflecting the system status</li> <li>▪ Events</li> <li>▪ Real-Time Data</li> <li>▪ Access to controls to send manual set points via web interface</li> </ul> </li> <li>• System Remote Interaction for data collecting: Modbus read, email alerts, SNMP traps and NTP: <ul style="list-style-type: none"> <li>▪ Modbus TCP/RS485 Read Only</li> <li>▪ Email Notification from a certain alarm level (SMTP)</li> <li>▪ SNMP v1, v2c, v3 Read Only and Traps</li> <li>▪ NTP Protocol</li> </ul> </li> <li>• Cybersecurity Capabilities: <ul style="list-style-type: none"> <li>▪ Firewall access</li> <li>▪ https with self-signed /standard certificate</li> </ul> </li> <li>• 3 Levels of User Roles: <ul style="list-style-type: none"> <li>▪ Basic, Expert, Admin roles give access to different parameters</li> <li>▪ User Role Management via Admin login</li> </ul> </li> <li>• Provides basic power management capabilities, including battery regulation (with Sierra modules): <ul style="list-style-type: none"> <li>▪ UPS for AC loads &amp; UPS for AC and DC loads with Bidirectionality on DC port</li> <li>▪ Battery Regulation Algorithms: CC-CV, Boost, Temperature Compensation, Battery Test, Battery Disconnect</li> </ul> </li> </ul> |
| 2              | Operation extension        | <ul style="list-style-type: none"> <li>• Reporting, configuration and control via Machine-to-Machine Interface: <ul style="list-style-type: none"> <li>▪ Customized Boolean Expressions for Relay control (PLC)</li> <li>▪ Data recordings and charts display</li> <li>▪ Modbus TCP/ RS485 and SNMP Read &amp; Write</li> </ul> </li> <li>• Enhanced Cybersecurity Capabilities: <ul style="list-style-type: none"> <li>▪ RADIUS (Remote Authentication Dial-In User Service)</li> <li>▪ IEEE 802.1X Standard (DoT.1X) - Authentication with SCEP with automatic certificate renewal</li> <li>▪ Https connection (custom/official certificate)</li> </ul> </li> </ul>                                                                                                                                                                                                                                                                                                                                                                                                                                                                                                                                                                                                                                                                                                                                                                                                                                                                                                                                                                                                            |

|                                     |                                  |                                                                                                                                                                                                                                                                                                                                                                                                                                                                                                                                                                                                                                                                                                                                                                                                                                                                                                                                                                                                                                         |
|-------------------------------------|----------------------------------|-----------------------------------------------------------------------------------------------------------------------------------------------------------------------------------------------------------------------------------------------------------------------------------------------------------------------------------------------------------------------------------------------------------------------------------------------------------------------------------------------------------------------------------------------------------------------------------------------------------------------------------------------------------------------------------------------------------------------------------------------------------------------------------------------------------------------------------------------------------------------------------------------------------------------------------------------------------------------------------------------------------------------------------------|
| 3                                   | Equipment extension              | <ul style="list-style-type: none"> <li>• Communication with Third Party device: <ul style="list-style-type: none"> <li>▪ Communication with any interfaced third party device (MPPT, SunSpec modbus inverters, smart batteries, meters...)</li> <li>◆ May require additional cost due to interfacing service if the device has not been interfaced yet. Interfacing service to be provided by CE+T</li> <li>◆ Maximum number of devices depends on the device itself</li> </ul> </li> <li>• Communication with additional CE+T devices: <ul style="list-style-type: none"> <li>▪ One or several Power Extension Kits, i.e. communication with more than 32 of Bravo 25 or Sierra 25 converters</li> <li>▪ Several kinds of modules in a single system</li> </ul> </li> </ul>                                                                                                                                                                                                                                                            |
| 5<br>(2+3)                          | Operation & Equipment extensions | <ul style="list-style-type: none"> <li>• Contains all the content of Operation and Equipment licenses</li> </ul>                                                                                                                                                                                                                                                                                                                                                                                                                                                                                                                                                                                                                                                                                                                                                                                                                                                                                                                        |
| 6                                   | Power management extension       | <ul style="list-style-type: none"> <li>• Contains all the content of Operation and Equipment licenses</li> <li>• Advanced Battery Management (only with Sierra 25 - 48/277 and Sierra 25 - 380/230): <ul style="list-style-type: none"> <li>▪ Maximum Discharging Current limitation</li> <li>▪ State of Charge Operating Range</li> <li>▪ Top-Off Charge</li> </ul> </li> <li>• Tools for PMS Functionalities (only with Sierra 25 - 48/277 and Sierra 25 - 380/230): <ul style="list-style-type: none"> <li>▪ Grid Interactive converter parameters</li> <li>▪ Access to converter parameters for AC-out coupling</li> </ul> </li> <li>• Power Management System (PMS) functionalities (only with Sierra 25 - 48/277 and Sierra 25 - 380/230): <ul style="list-style-type: none"> <li>▪ Peak-Shaving</li> <li>▪ Self-Consumption/Off-Grid: Dispatchable Source Control, AC-out Coupled and Load-Shedding</li> <li>▪ Forced Import/Export</li> </ul> </li> <li>• Scheduling Tool: calendar to configure PMS functionalities</li> </ul> |
| 4<br>(existed before PMS extension) | Customization extension          | <ul style="list-style-type: none"> <li>• Contains all the content of Operation, Equipment and Power management licenses</li> <li>• Gives access to scripting: <ul style="list-style-type: none"> <li>▪ The scripts are developed by CE+T</li> <li>▪ Only accessible on request after discussion and approval with the Engineering/Pre-sales team</li> <li>▪ Price depends on the request</li> </ul> </li> </ul>                                                                                                                                                                                                                                                                                                                                                                                                                                                                                                                                                                                                                         |

Refer to “Login”, page 38 to Login into web interface.

To know about the available license options, log in to the web interface, go to *System > Site > Data* , and scroll down to check the ID DA11 in the Controller section.

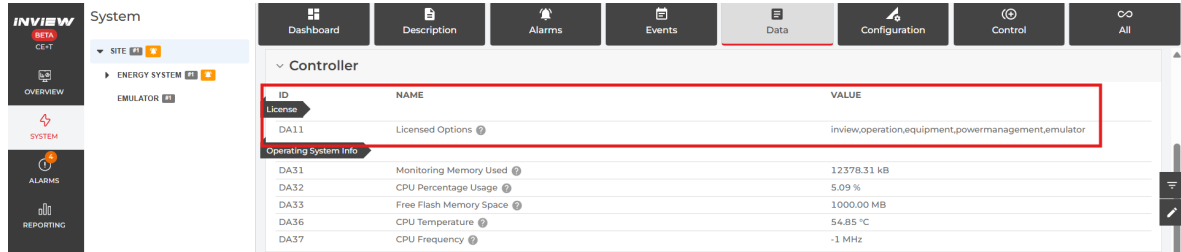

## 4.8 Accessories

### 4.8.1 MBB (Measure Box Battery)

Measure Box Battery is a device which monitors the battery parameters such as battery voltage, current, temperature and LVD. In addition it contains extended Digital Inputs and Output Relay contacts. Measure Box Battery has 60 V and 500 V variants for low and high DC power, respectively.

It is possible to connect up to maximum three MBB 60V and two MBB 500V in parallel on the power supply available on the CAN/iso RS485 ports of the Inview Slot, Inview S and Inview X/X+. If more MBB are connected in parallel or when used with Inview XC, use an external power supply to power the MBB.

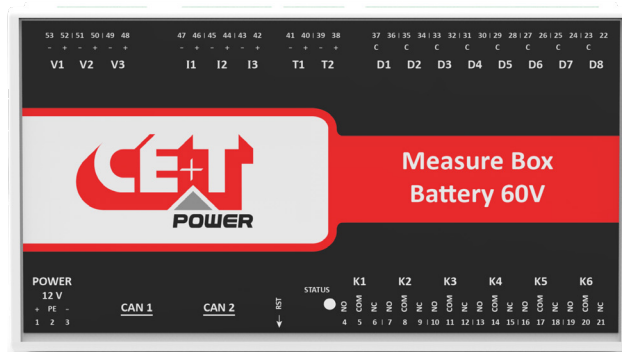

Measure Box Battery 60V

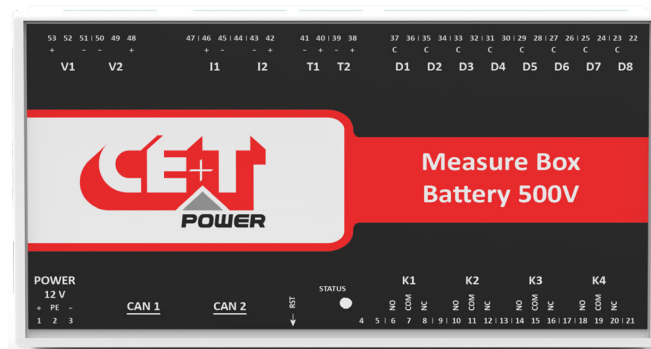

Measure Box Battery 500V

#### 4.8.2 Measure Box Battery Specifications

| Models                      | Measure Box Battery 60V                 | Measure Box Battery 500V                                                        |
|-----------------------------|-----------------------------------------|---------------------------------------------------------------------------------|
| VDC measurements            | 3 Vdc inputs                            | 2 Vdc inputs                                                                    |
| VDC range                   | 0 - 60 Vdc                              | 0 - 500 Vdc                                                                     |
| IDC measurements            | 3 Idc inputs                            | 2 Idc inputs                                                                    |
| IDC range                   | 0 - 75 mV shunt                         |                                                                                 |
| Temperature sensors         | 2 (type: LM335)                         |                                                                                 |
| Output relays               | 6<br>0-60 Vdc, 30 W (max 0.5 A)         | 4<br>0-60 Vdc, 60 W (max 6 A); 60-250 Vdc, 40 W<br>0-250 Vac, 1500 VA (max 6 A) |
| Digital inputs              | 8 (from free potential contact)         |                                                                                 |
| Communication               | CAN                                     |                                                                                 |
| Power supply                | Through Inview or External 12 Vdc input |                                                                                 |
| Power consumption           | 1.8 W (6 output relays activated)       | 2.4 W (4 output relays activated)                                               |
| Synoptics                   | 1 LED                                   |                                                                                 |
| Mounting                    | DIN Rail                                |                                                                                 |
| Operating Temperature Range | -20 to 65°C                             |                                                                                 |
| Dimension (W x H x D)       | 160 x 97 x 38 mm                        |                                                                                 |
| Weight                      | 240 g                                   |                                                                                 |
| Part number                 | T602006000                              | T602006011                                                                      |

## 5. Installation

### 5.1 Site preparation

- All cables should be copper wire and must be rated for min 90°C (194°F).
- All cables must be sized according to the rated current of the Inview / Measure Box Battery and to the customer terminal connection.
- All power and signal cables should be routed properly.

### 5.2 Installing - Inview Slot

1. Place the Inview Slot and slide into the shelf.
2. Push the unit firmly until the controller rear part is engaged correctly with shelf.
3. Make sure the latch is locked in the shelf.

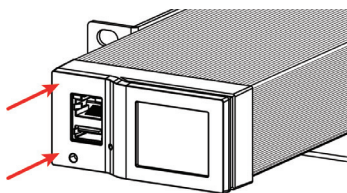

*Place the module & slide into the shelf*

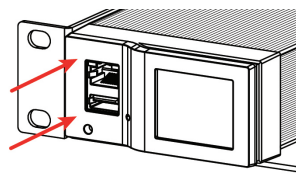

*Push firmly until module is engaged*

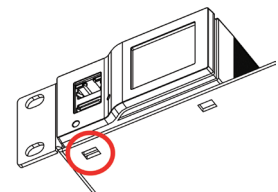

*Make sure the latch is locked in the shelf*

### 5.3 Mounting - Inview S

Before mounting the Inview S in the system, route all the required connection cables from the system and place near to the Inview S mounting location.

#### 5.3.1 Panel Mounting

1. Place the Inview S in the panel sheet.
2. Lock all the four latches at the rear side of the Inview S in the panel sheet.
3. Connect required connection cables to the Inview S.
4. Mount the panel sheet in the system with screws.

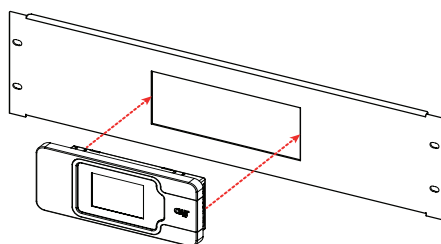

*Place the Inview S in the panel sheet*

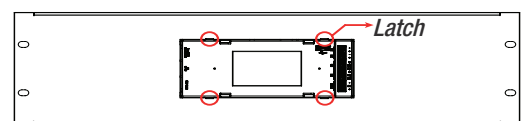

*Lock it with four latches at rear*

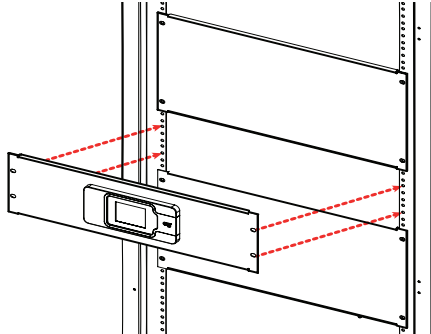

*Connect wires and place the panel sheet in the cabinet*

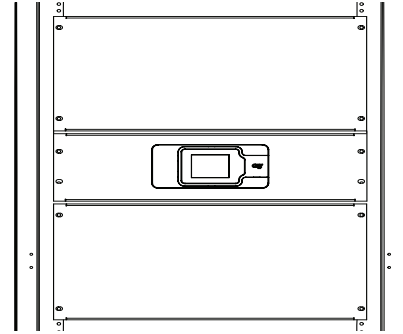

*Mount the panel sheet with screws*

**Note:** To know about panel sheet dimension and cut-out details, refer “17. Annexe 7: Inview Panel Sheets”, page 98.

### 5.3.2 Din-rail Mounting

1. Place the two clips on the mounting bracket and fix them with M4 x 8 mm screws and washers.
2. Place the assembled mounting bracket on the Inview S rear side and fix it with self-tapping 2.9 x 9.5 mm screws.
3. Fix the Inview S assembly in the Din-rail.

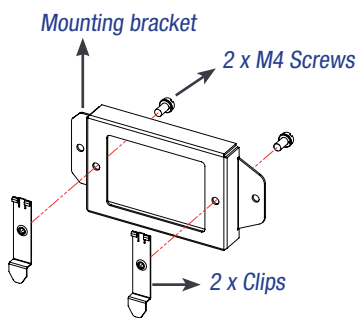

*Place clips on the mounting bracket*

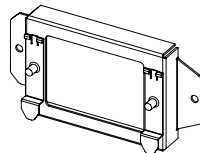

*Fix it with M4 Screws*

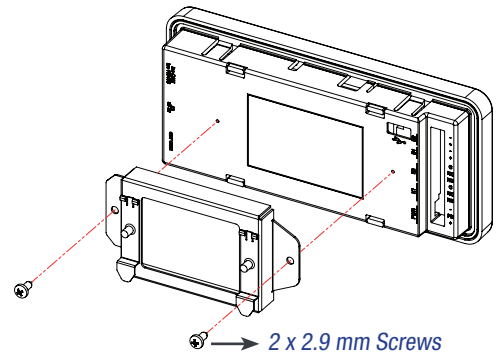

*Place the mounting bracket assembly on the Inview S*

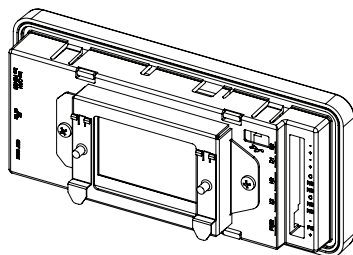

*Fix it with 2.9 mm Screws*

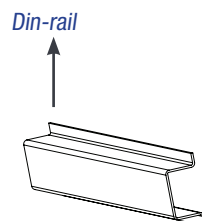

*Take the Inview assembly near to the Din-rail*

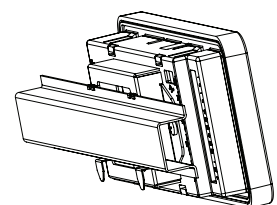
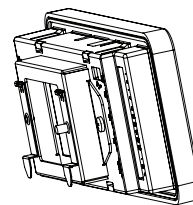

*Fix it on the Din-rail*

## 5.4 Mounting - Inview X / X+

Before mounting the Inview X / X+ in the system, route all the required connection cables from the system and place near to the Inview X / X+ mounting location.

1. Place the Inview X / X+ in the panel sheet.
2. Fix the Inview X / X+ in the panel sheet using four screws at the rear side.
3. Connect required connection cables to the Inview X / X+.
4. Place the panel sheet in the system and fix it with screws.

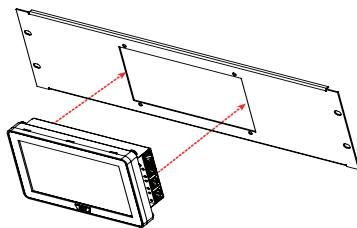

*Place the Inview X in the panel sheet*

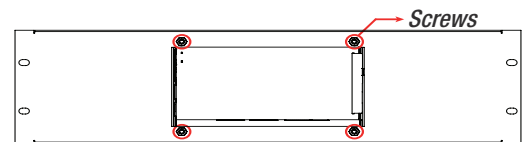

*Fix it with four screws*

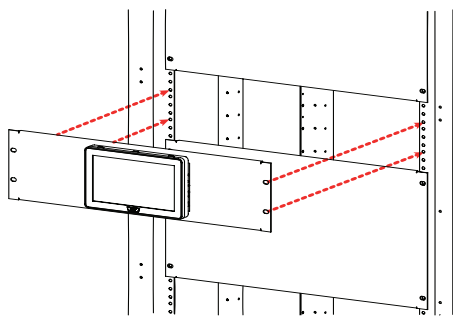

*Connect wires and place the panel sheet in the cabinet*

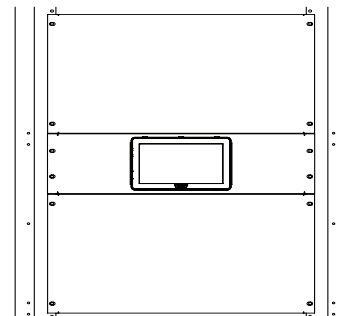

*Fix the panel sheet with screws*

**Note:** To know about panel sheet dimension and cut-out details, refer [“17.2 Inview X / X+ - Panel Sheet”](#), page 99

## 5.5 Installing - Inview XC

Before mounting the Inview XC in the system, route all the required connection cables from the system and place them near the Inview XC mounting location.

**Note:** To know about Inview XC dimensions and hole details, refer "[17.3 Inview XC - Dimensions](#)", page 99.

### 5.5.1 Wall mounting

- Clean the wall surface.
- Lift up and hold the controller in position and mark the holes.
- Drill holes on the marked points.
- Fix the controller on the wall using the screws.

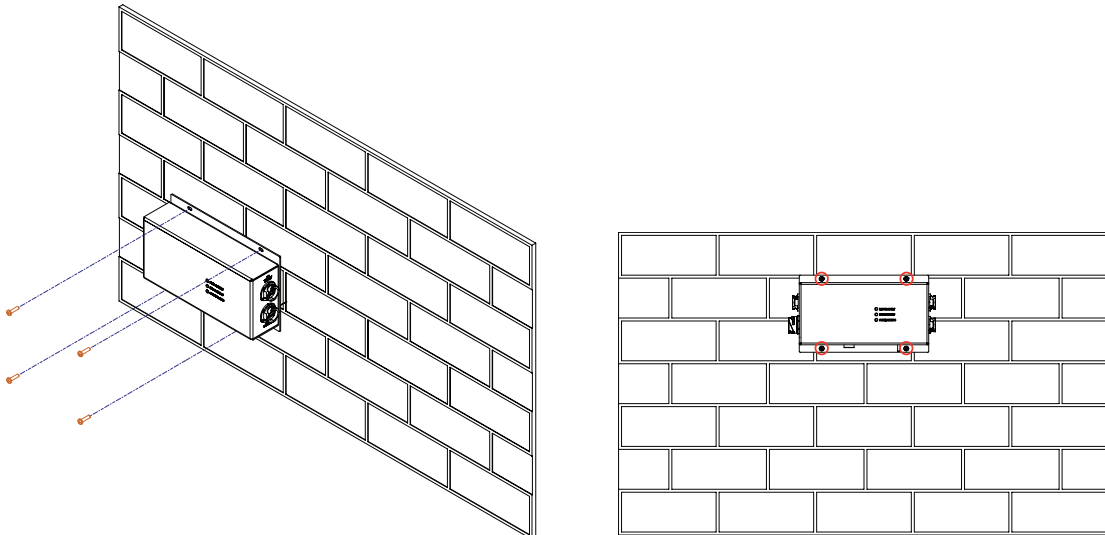

### 5.5.2 Pole mounting

Use pole mounting kits to mount the Inview XC on a pole. We suggest using the PK-121 Pole Mount Kit from Polycase (with a rail length of 305 mm) ([link](#)), or any other pole mounting kit could be used. Refer for the fixations' hole spacing.

### 5.5.3 Panel mounting

- Place the Inview XC in the panel sheet.
- Fix the Inview XC in the panel sheet using four screws at the rear side.
- Connect required connection cables to the Inview XC.
- Place the panel sheet in the system and fix it with screws.

## 5.6 Hardware Connections

This section describes the hardware connections of the Inview controllers and measure boxes (MBB). For further information about system interconnections, refer to the converters' user manuals (Sierra, Bravo, Flexa,...) available on [www.cet-power.com](http://www.cet-power.com).

### 5.6.1 Inview Slot - Connections

Inview Slot has an ETH port and USB at the front. Output relays, digital inputs, CAN and power connections are present at the rear side of the Inview Slot connected shelf.

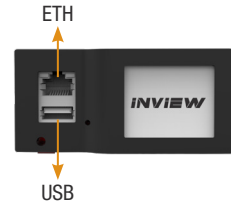

#### 5.6.1.1 Inview Slot - Front connections

- **LAN port** is used for network connectivity and user can access the system information in the Web Interface. The default static IP address is *10.250.250.1/24* (the "/24" indicates the Subnet mask address: *255.255.255.0*)
- **USB port** is used for internal factory purpose.

#### 5.6.1.2 Inview Slot - Shelf rear connections

- **Digital Inputs (D1 and D2):** Two digital inputs are available for customer connections.
- **Output Relays (K1 and K2):** Two output relays are available and can be used for Major and Minor Alarms.
- **CAN Modbus RTU (RS485) port** is used to establish communication between Inview Slot and accessories. It also provide the +12 Vdc power to one Measure Box Battery. To know about RS485 pin details, refer to the section 5.6.8, page 29.
- **iso CAN terminal** is used to establish CAN communication.  
(Note: This new CAN feature is available in the PCBs purchased in / after 2025 only)
- **Power:** The redundant external auxiliary +12 Vdc and the power consumption is **5W**. By default, Inview Slot takes power from DC bus. If DC is not present, it takes +12 V from external Auxiliary power supply converter (AC to DC).

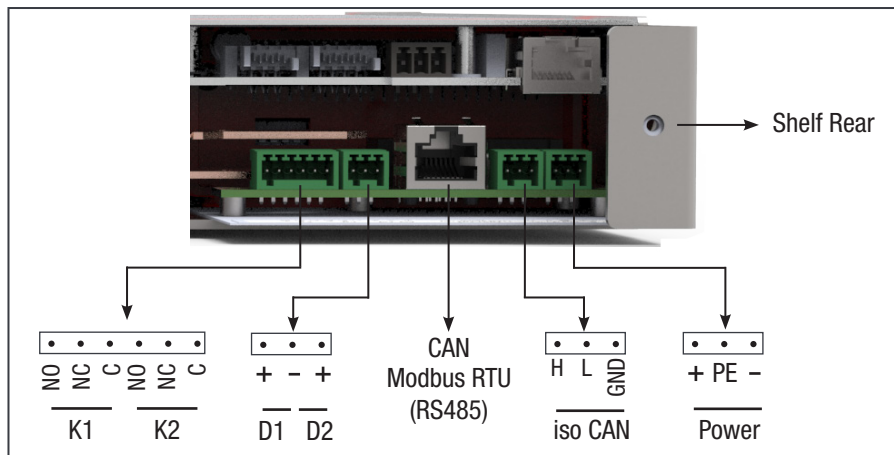

### 5.6.2 Inview S - Connections

Inview S is composed of multiple network ports, digital inputs and Output Relay contacts which are present at the rear side of the product.

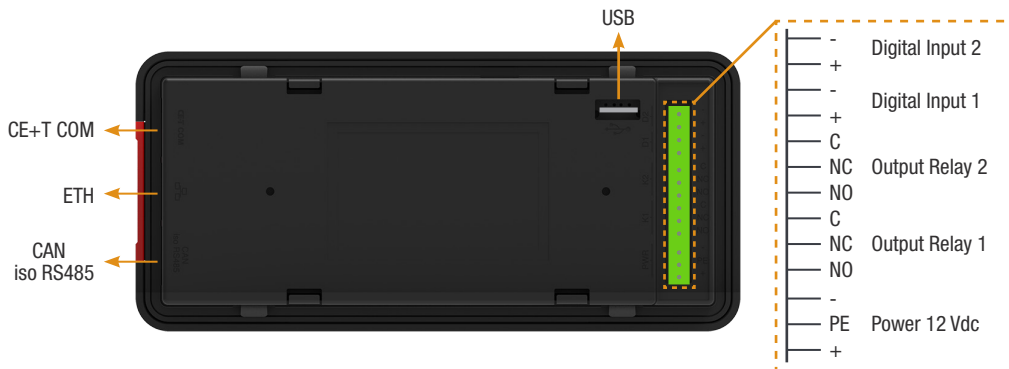

- **CE+T COM** port is dedicated to establish connection between Inview S and converters.
- **ETH** (  ) port is used for network connectivity and user can access the system information in the Web Interface and SNMP. The default static IP address is 10.250.250.1/24 (the "/24" indicates the Subnet mask address: 255.255.255.0)
- **CAN / iso RS485** port is used to establish communication between Inview S and Measure Box Battery. To know about RS485 pin details, refer to the section 5.6.8, page 29. It also provides the +12 Vdc power to three MBB 60V or two MBB 500V which are connected in series.
- **USB** port is used for internal factory purpose.
- **Digital Inputs (D1 and D2):** Two digital inputs are available for customer connections.
- **Output Relays (K1 and K2):** Two output relays are available and it is used for Major and Minor Alarms.
- **Power:** +12 Vdc is required for powering the controller and the power consumption is 5W. (CE+T can provide auxiliary power supply converter (48 to 12 Vdc). Part number is **T602004120**).

### 5.6.3 Inview X / X+ - Connections

Inview X / X+ composed of multiple network ports and inbuilt free potential contacts.

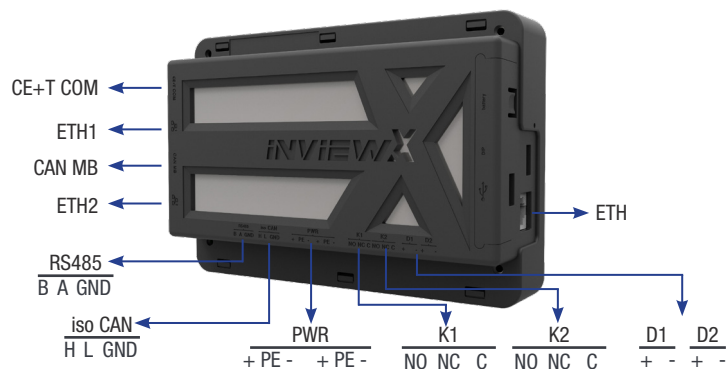

- **CE+T COM** port is dedicated to establish connection between Inview X / X+ and converters.
- **ETH** ports are used for network connectivity, and user can access the system information through the web

interface.

- **ETH Front:** DHCP server, providing access to the configuration at URL <https://inview.local> or <https://10.250.252.1>
  - Intended for direct connection of a laptop computer.  
**Warning: Do not connect this port to the network, as it might interfere with other DHCP servers.**
- **ETH1:** Main network interface
  - Default static IP address: 10.250.250.1/24
  - It can be configured to other static addresses or as a DHCP client in a web-based configuration interface
- **ETH2:** Secondary network interface
  - It is dedicated to CE+T accessories like Inview Gateway and do not connect to the network
- **CAN MB** port is used to share the system information to the Measure Box Battery. It also provides the +12 Vdc power to three MBB 60V or two MBB 500V which are connected in series. To know about pin details, refer to the section 5.6.8, page 29.
- **iso CAN** is used for CAN communication.
- **RS485** is used for Modbus communication.
- **USB** port is used for internal factory purpose.
- **Digital Inputs (D1 and D2):** Two potential free Digital Inputs are available for customer connections.
- **Output Relays (K1 and K2):** Two output relays are available and can be used for Major and Minor alarms.
- **Power:**
  - +48V supply is required to power up the Inview X.
  - +12V, +24V or +48 are required to power up the Inview X+.
  - Two terminals are available for redundancy purposes. Note that an alarm (AL100) is monitoring the use of that dual source and should be disabled in case only one of those is used.

#### 5.6.4 Inview XC - Connections

- **CE+T COM** port is dedicated to establish connection between Inview XC and converters.
- **ETH port:** used for network connectivity and user can access the system information in the Web Interface and SNMP. The default static IP address is 10.250.250.1/24.
- **iso CAN/ RS485 ports:** for Modbus RTU and CAN communication. This port should be used for the communication with the Measure Box Batteries. An external power supply is needed for the Measure Box Battery. To know about the pin details, refer to the following figure.
- An “Others” port that comprises:
  - Digital inputs (D1 and D2): Two potential free Digital Inputs are available for customer connections.
  - Output relays (K1 and K2): Two output relays are available and can be used for Major and Minor alarms.
  - An additional iso CAN for CAN communication.

For Inview XC, IP65 rated NLINK0 connectors must be used. Refer to the below picture for Inview XC connectors' pin details.

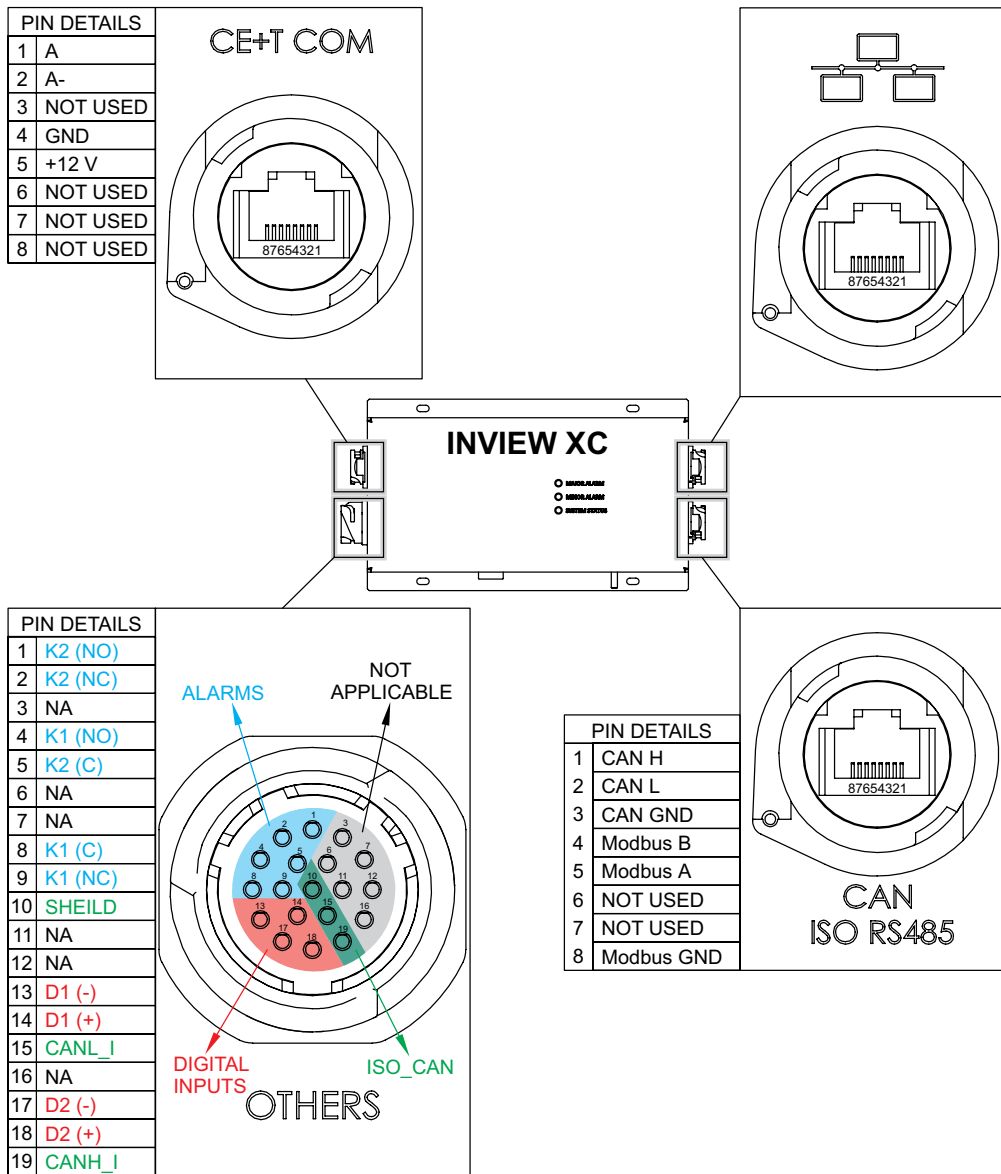

**Note:** To solder pins together on the Inview XC side of the 19 pin connector, use a magnifier to view the pin numbers. The numbering corresponds to the pin details given here above.

### 5.6.5 MBB (Measure Box Battery) - Connections

MBB is composed of multiple digital inputs and analog outputs.

- **Voltage (V1 to V3)** is used to monitor the voltage of DC. Ensure the polarity while wiring.
  - V1: common DC 48V voltage
  - V2: string 1 monitoring
  - V3: string 2 monitoring (Not available in MBB 500V)



### 5.6.8 CAN / ModBus (RS485) Pin Details

| Pin Number | Name       | Description                     |
|------------|------------|---------------------------------|
| 1          | CAN_H      | CANH pin for CAN protocol       |
| 2          | CAN_L      | CANL pin for CAN protocol       |
| 3          | GND_Can    | Ground pin for CAN protocol     |
| 4          | ModBus_B   | ModBus B through serial port    |
| 5          | ModBus_A   | ModBus A through serial port    |
| 6          | GND        | Ground pin for MBB power supply |
| 7          | +12 VDC    | +12 VDC for MBB power supply    |
| 8          | GND_ModBus | ModBus ground                   |

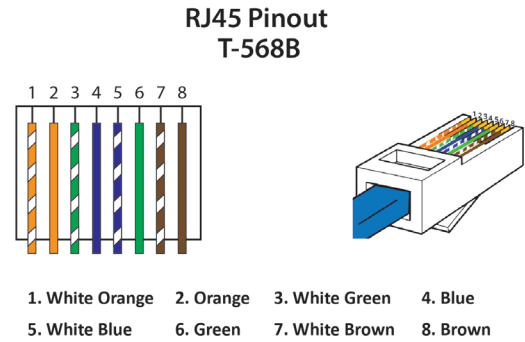

**Note:** The wire colours might vary, but make sure the wire positions are exactly crimped.

### 5.6.9 Inview Slot with Bravo 10 and Sierra 10 - System

In Bravo 10 and Sierra 10 systems, the Inview Slot and Measure Box Battery should be connected as per the following:

1. Connect “CAN Modbus RTU (RS485)” port in Inview Slot and “CAN1” port in MBB 60V and MBB 500V. **(Note: MBB is not mandatory for Bravo Systems)**
2. Connect power to Inview Slot and MBB (if needed) from auxiliary power supply kit.

**Note:** Use an auxiliary power supply only if more than two MBB 500V or three MBB 60V are connected to the system.

#### System with Inview Slot and MBB

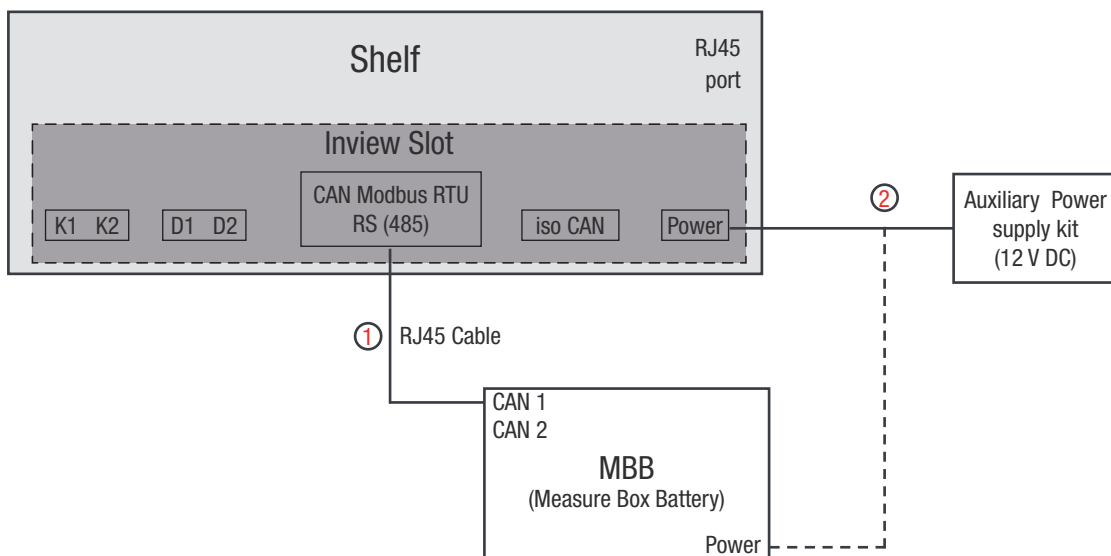

For more information about wiring refer “15.1 Inview Slot with MBB”, page 93.

### 5.6.10 Inview S with Bravo and Sierra - System

In Bravo and Sierra systems, the Inview S and Measure Box Battery should be connected as per the following:

1. Connect “RJ45” port in shelf and “CE+T COM” port in Inview S using RJ45 straight cable.
2. Connect “CAN / iso RS485” port in Inview S and “CAN1” port in MBB 60V and MBB 500V.  
(Note: MBB is not mandatory for Bravo Systems)
3. Connect the auxiliary power supply kit to power the Inview Slot, Inview S, Inview X and MBB (if needed).

Note: Use an auxiliary power supply only if more than two MBB 500V or three MBB 60V are connected to the system.

#### System with Inview S and MBB

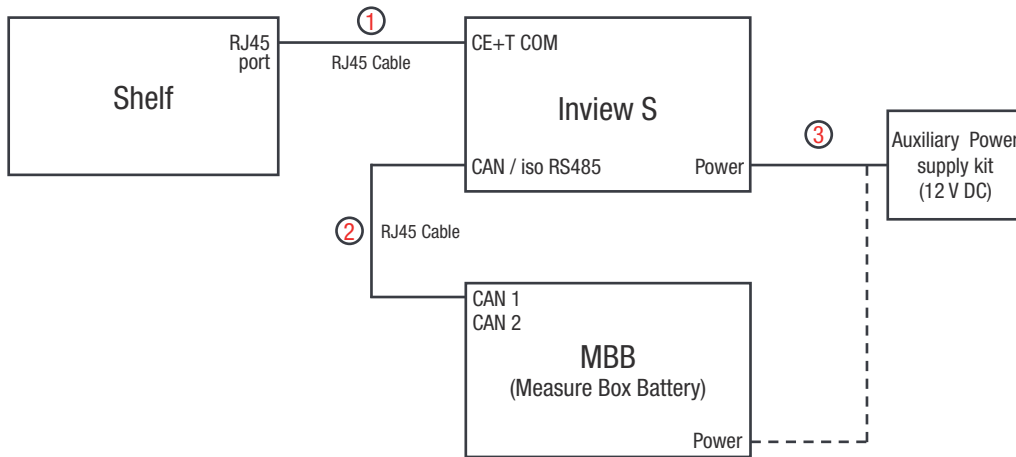

For more information about wiring refer “15.2 Inview S with MBB”, page 94.

### 5.6.11 Inview X / X+ with Bravo and Sierra - System

In Sierra system, the Inview X / X+ and Measure Box Battery should be connected as per the following:

1. Connect “RJ45” port in shelf and “CE+T COM” port in Inview X / X+ using RJ45 straight cable.
2. Connect “CAN MB” port in Inview X / X+ and “CAN1” port in MBB 60V / MBB 500V.  
(Note: MBB is not mandatory for Bravo Systems)
3. Connect 48 V supply to Inview X / X+ from AC to DC adapter and Battery.

**System with Inview X / X+ and MBB**

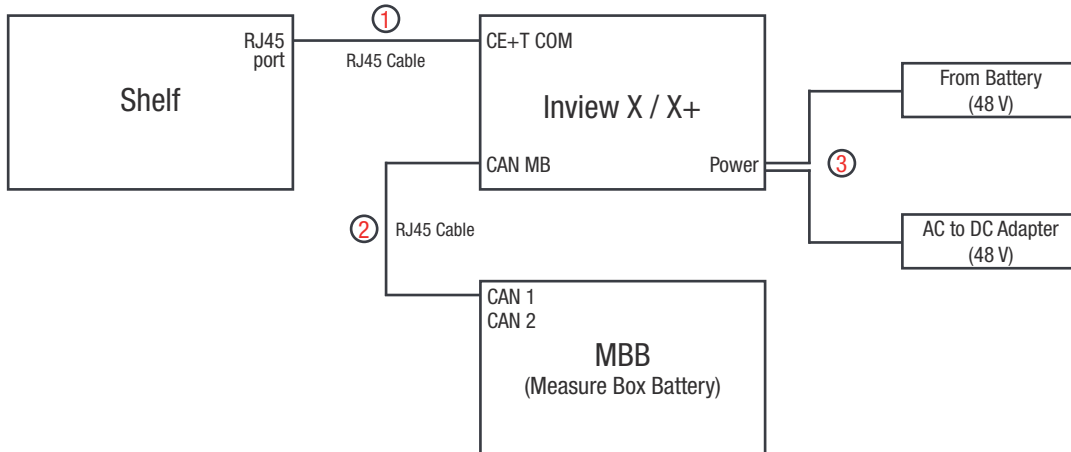

For more information about wiring refer "15.3 Inview X / X+ with MBB", page 95.

- Use an auxiliary power supply (12 VDC) if more than two MBB 500V or three MBB 60V are connected to the system.

**5.6.12 Inview XC with Sierra XC - System**

In Sierra XC module, the Inview XC should be connected as per the following:

- Connect "COM" port in Sierra XC System and "CE+T COM" port in Inview XC using RJ45 straight cable.
- Connect "CAN ISO RS485" port in Inview XC and "CAN1" port in MBB 60V and MBB 500V.  
(Note: Sierra XC provides power to Inview XC only and not to MBB. An external power supply is required to power up the MBB)
- Connect power to MBB from auxiliary power supply kit

**System with Inview XC and MBB**

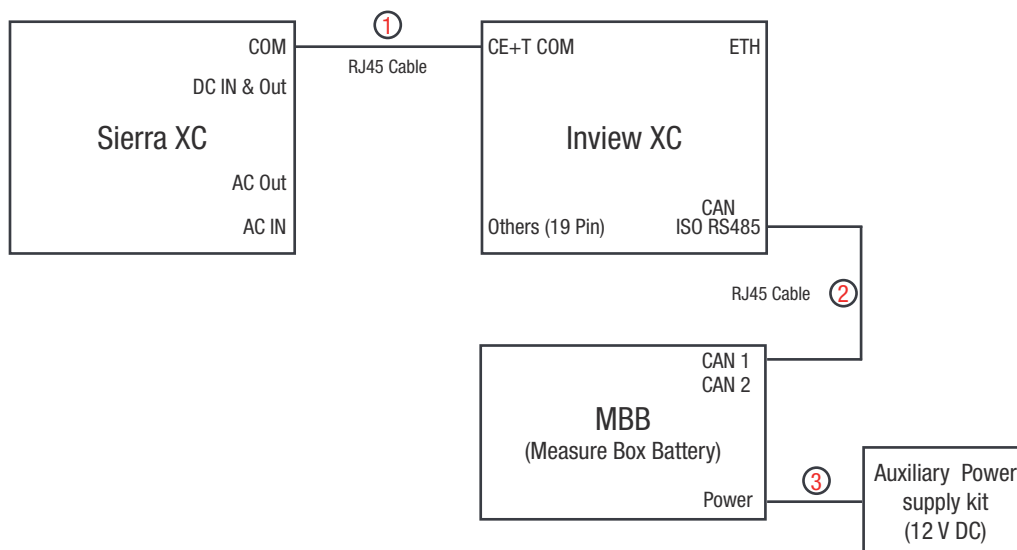

For more information about wiring refer "15.4 Inview XC with MBB", page 96.

## 6. Overview - Web Interface

The web interface of all the Inview controllers is the same. The Inview web interface allows the user to interact with system, access, configure and modify the system parameters. The below tree provides an overview of the menu structure in the web interface.

*Note: Widgets varies depending upon the topology selection.*

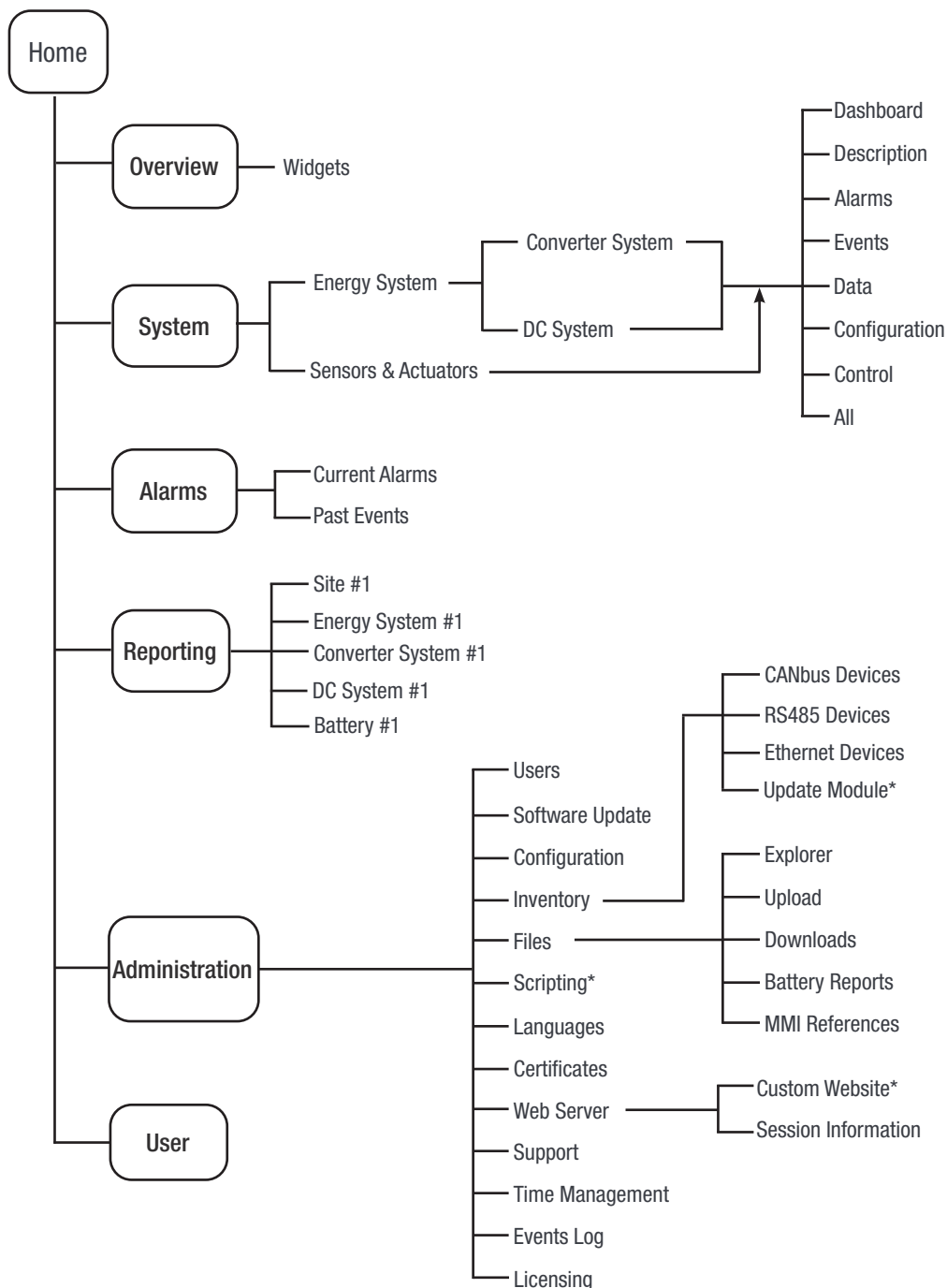

\*: Requires customization license

## 6.1 Interface

### 6.1.1 INVIEW Display Option



The icons provide quick access to the corresponding pages.

- 1 → **INVIEW:** Click the **INVIEW** logo to navigate to the home page from any menu page in the system.
- 2 → **Notification:** Click the **NOTIFICATION** icon to open the Alarm page and view Current Alarms and Past Events.
- 3 → **Widgets:** Click Widget to view more detailed data and information related to the selected widget.
- 4 → **Control:** Shortcuts to specific control functions that are selected from the drop down list.
- 5 → **EDIT:** Click **EDIT** to edit the main screen overview (widgets/controls/data).
- 6 → **OVERVIEW:** Click **OVERVIEW** to navigate to main screen.
- 7 → **SYSTEM:** Click **SYSTEM** to navigate to advance settings of power system, connectivity, PMS and more.
- 8 → **ALARMS:** Click **ALARMS** to navigate to the Alarm page to view Current Alarms and Past Events.
- 9 → **REPORTING:** Click **REPORTING** to display data graph (Data from Site, Energy system, Converter system DC System, Battery, etc..).
- 10 → **DATA (1 & 2):** The **DATA 1** and **DATA 2** charts shows the variable data in both formate (Graph Chart or Bar Chart).
- 11 → **ADMINISTRATION:** Click **ADMINISTRATION** to access the User management, Software update, Configuration, Inventory, files, Languages selection, Certificates, Web Server, Support package, Time management, Events log and Licensing.
- 12 → **USER:** Click **USER** to access the information of login account such as Quick Links to Save Configuration, Save Inventory and Reboot controller, Website links to download software and documents, Change Password and Logout.

### 6.1.2 Home Page

The default home page shows Widgets, Optional tabs and Charts (Graph or Bar graph). The widgets displays details system information. The optional tabs can be selected based on the requirement. The charts shows variable data in a graph or bar graph. To perform any configuration, refer to the section 7.9, page 55.

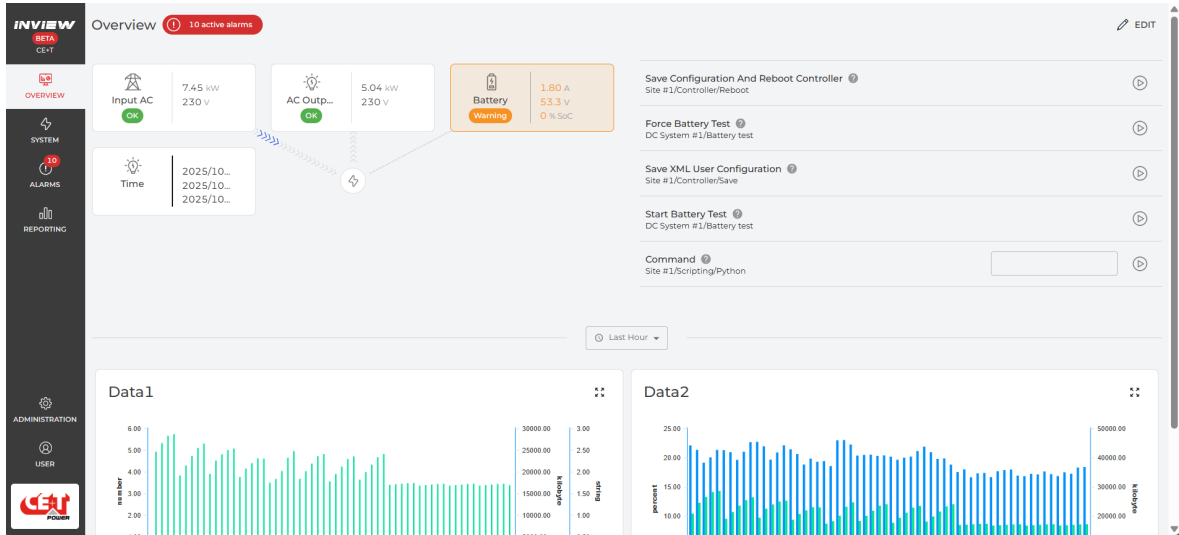

- Click the AC Input Widget to view the corresponding details on right side on the screen.

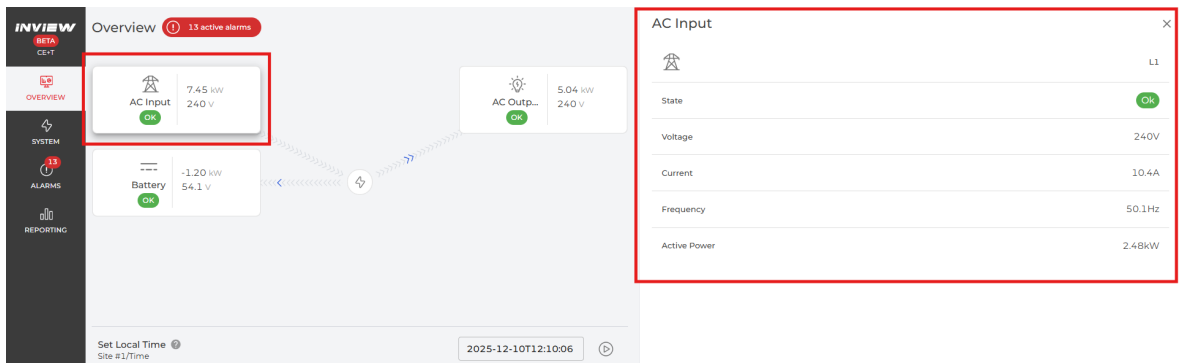

### 6.1.3 Widgets

The Inview (Slot, S, X) widgets do not appear same as in the web interface and LCD touch screens. Only in Inview X+, the Widgets appears identical in both web interface and LCD touch screen. The flexible view can be configured depending on the system topology with the following types of widgets:

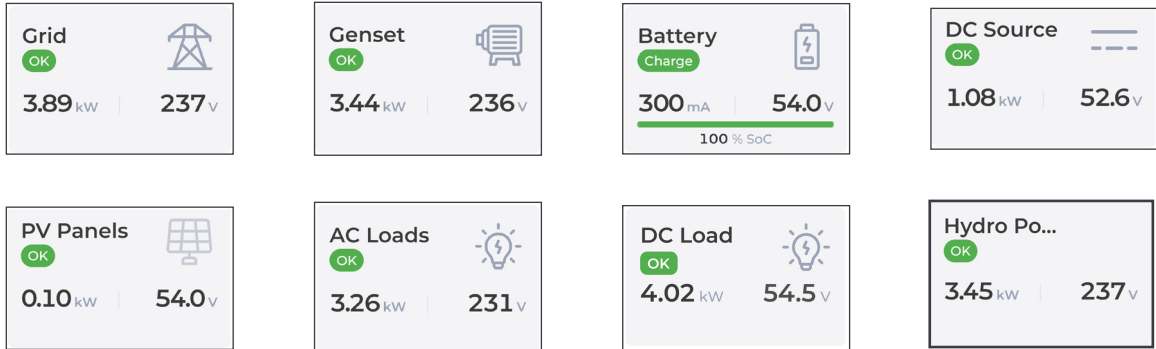









Source and Load are the different convention signs used for the different assets. The conventions of the different assets are listed in the below table. Based on the type of asset, the widget icon is displayed on the home page.

| S.No | Widget      | Convention Type | Power Supplied | Power Received |
|------|-------------|-----------------|----------------|----------------|
| 1    | Grid        | Source          | Positive       | Negative       |
| 2    | Genset      | Source          | Positive       | Negative       |
| 3    | Battery     | Load            | Negative       | Positive       |
| 4    | DC Source   | Source          | Positive       | Negative       |
| 5    | Solar       | Source          | Positive       | Negative       |
| 6    | AC Load     | Load            | Negative       | Positive       |
| 7    | DC Load     | Load            | Negative       | Positive       |
| 8    | Hydro Power | Source          | Negative       | Positive       |



## 6.2 Web page Controls

Click the control icons to perform the configuration or setup.

| Controls                                                                            | Description                                                                                                                                                            |
|-------------------------------------------------------------------------------------|------------------------------------------------------------------------------------------------------------------------------------------------------------------------|
|    | Filters: Page displays depending upon the filter selection.                                                                                                            |
|    | Page changes to edit mode and the user can change the parameters. If any parameter value is changed, the edit icon changes to modification icon and displays the list. |
|    | Rename the parameter name.                                                                                                                                             |
|    | Select the corresponding parameter to display the dashboard data.                                                                                                      |
|  | Visibility of the parameters , Mark the check box to view                                                                                                              |
|  | On-Board help: Provide a short description to help to know about the corresponding parameters.                                                                         |
|  | Page or section expands.                                                                                                                                               |
|  | Page or section collapse.                                                                                                                                              |
|  | Particular section opens in a new tab.                                                                                                                                 |
|  | Particular section open as a pop-up.                                                                                                                                   |
|  | Drop down list – more options are present.                                                                                                                             |
|  | Delete / Clear the corresponding parameter.                                                                                                                            |

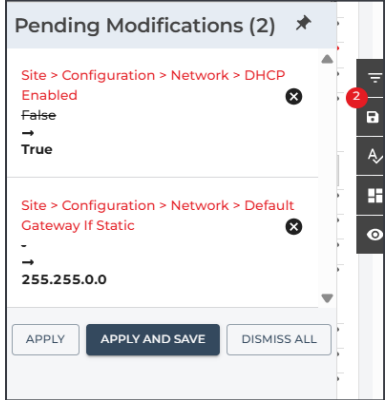

Note: Filter, Edit, Re-name and Dashboard icons are present at right side of the web page.

| Controls                                                                          | Description                                                                                                                                                                                                                                                                                                                                                                                                                                                                                                                                                                                                                                                                                                                                                                                                                                                                                                                                                                         |
|-----------------------------------------------------------------------------------|-------------------------------------------------------------------------------------------------------------------------------------------------------------------------------------------------------------------------------------------------------------------------------------------------------------------------------------------------------------------------------------------------------------------------------------------------------------------------------------------------------------------------------------------------------------------------------------------------------------------------------------------------------------------------------------------------------------------------------------------------------------------------------------------------------------------------------------------------------------------------------------------------------------------------------------------------------------------------------------|
|  | <p><b>Modifications list:</b> this list helps the user to overview the changes and can apply the required parameters.</p> <p><b>Apply:</b> Clicking on “<b>APPLY</b>” button, the controller accepts all the parameter changes in the modifications list.</p> <p><b>Apply and Save:</b> Clicking on “<b>APPLY AND SAVE</b>” button, the controller accepts all the parameter changes in the modifications list and saves them in the configuration file.</p> <p><b>Dismiss All:</b> Clicking on “<b>DISMISS ALL</b>” button, the controller rejects all the parameter changes in the modifications list.</p> <p>Clicking on  button, the controller rejects only the particular modification from the list.</p> <p><b>Note:</b> The number on the icon indicates the number of modifications in the list.</p>  |

## 7. Power System Settings

Once system is powered on, the Inview Slot, S, X, X+ or XC is up and ready for operation. Configuration and other parameters can be changed using the web interface. Perform the following procedure to configure the system through web interface.

### 7.1 Login

Open the web browser, type the default IP address **10.250.250.1** in the address field and press enter.

**Note:** Use any of the latest web browsers: Google Chrome, Mozilla Firefox, Safari, or Microsoft Edge.

Inview Slot, S, X, X+ and XC have three login – Basic, Expert and Admin. All three login is password protected.

The default password for all three logins is “1234”. It can be modified, refer section 7.2.1, page 39.

An auto-logout feature is available to avoid a user being connected all the time. When no action is performed for more than 10 minutes, the session will expire and goes to the login screen.

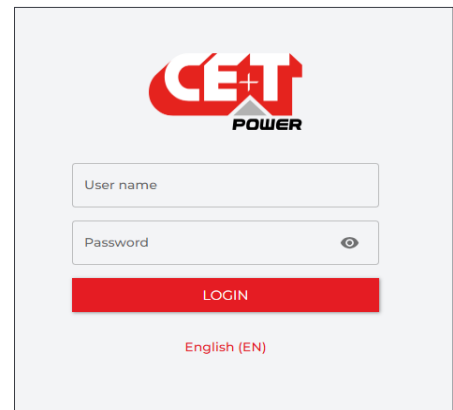

### 7.2 Users Management

The users page provides the access to create and modify the user accounts for web interface and PIN modification for LCD interface.

Navigate to **ADMINISTRATION > Users**, for user management.

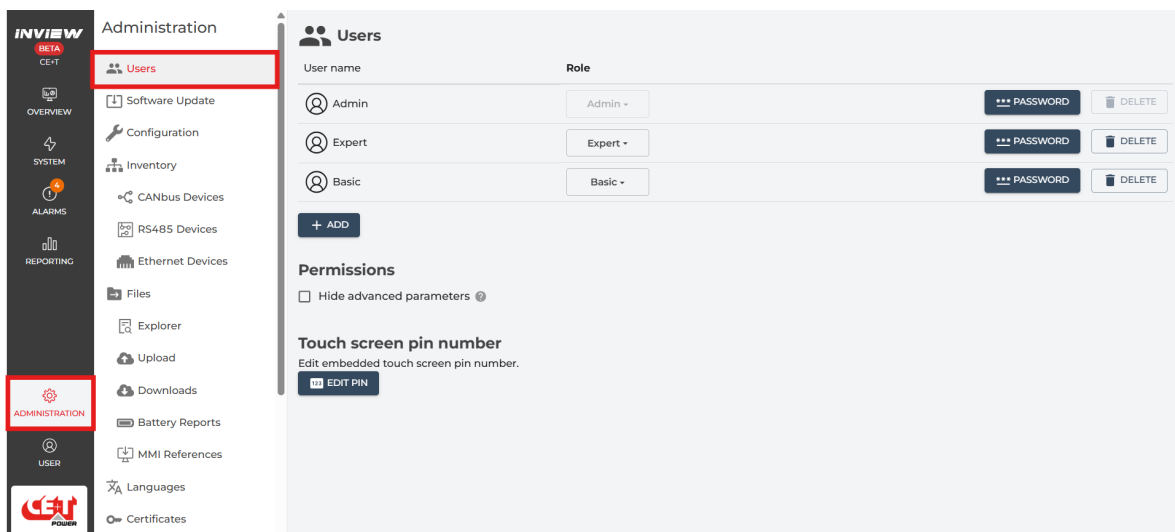

The screenshot shows the Inview web interface. On the left is a navigation menu with 'ADMINISTRATION' highlighted. The main content area shows the 'Users' management page. It includes a table with columns for 'User name' and 'Role'. Below the table are buttons for '+ ADD', 'Permissions', and 'Touch screen pin number'.

| User name | Role   | Actions          |
|-----------|--------|------------------|
| Admin     | Admin  | PASSWORD, DELETE |
| Expert    | Expert | PASSWORD, DELETE |
| Basic     | Basic  | PASSWORD, DELETE |

Below the table, there is a '+ ADD' button. Under 'Permissions', there is a checkbox for 'Hide advanced parameters'. Under 'Touch screen pin number', there is an 'EDIT PIN' button.

### 7.2.1 Web Interface - User account

Users can create up to **ten** accounts for web interface and assign role as Admin, Expert, or Basic.

- **Basic** – User can only view the parameters and download the files.
- **Expert** - User can access and modify all the applicable parameters, and can change their own password.
- **Admin** – User can access, modify all the applicable parameters, and manage user accounts. All parameters are displayed by default (**Note: The manufacturer created *Admin account* cannot be deleted**)

**Note:** The feature of creating and editing user account is available only in Admin privilege.

- **Creating a new user account**

- In Users page, Click on “+ADD” button. A pop window appears with the title “Add a new user.”
- Enter an appropriate user name and assign a role from the drop down list as Basic or Expert.
- Enter a new password, type the same password for confirmation, and then click **ADD** button. The password length should be at least eight characters.

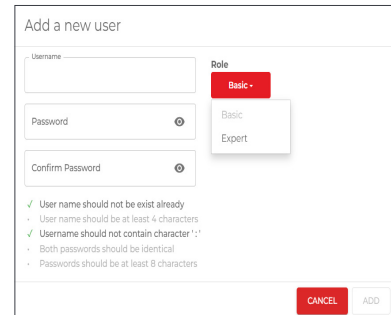

- **Editing the existing user account**

In the Users page, choose a user account which you like modify.

- Modify the privilege from the “**Role**” drop-down list as Expert or Basic.
- Click on “**PASSWORD**” button to edit existing password.
- Click on “**DELETE**” button to remove the user account.

### 7.2.2 LCD Interface - PIN number

Inview Slot, S, X, X+ and XC LCD interface do not have any user account; the user can view the system details and cannot modify the parameters. The LCD interface is protected with the PIN during any action request.

The default PIN is 1234.

- **Editing the LCD PIN number**

- Select *Administration > Users*.
- In users page, Click on “**EDIT PIN**” button below the “Touch screen pin number”.
- Enter a new pin, type the same for confirmation, and then click **OK**. The pin should be four characters.

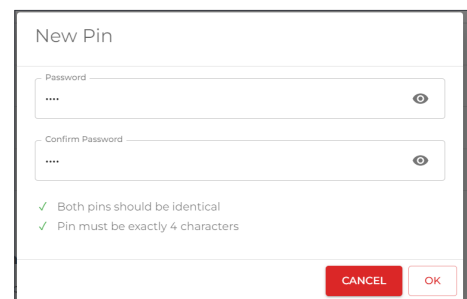

## 7.3 Site Management

### 7.3.1 Site Description

Navigate to *SYSTEM > SITE > Description*.

Enter the Site details such as *Site description, Location and Contact details*.

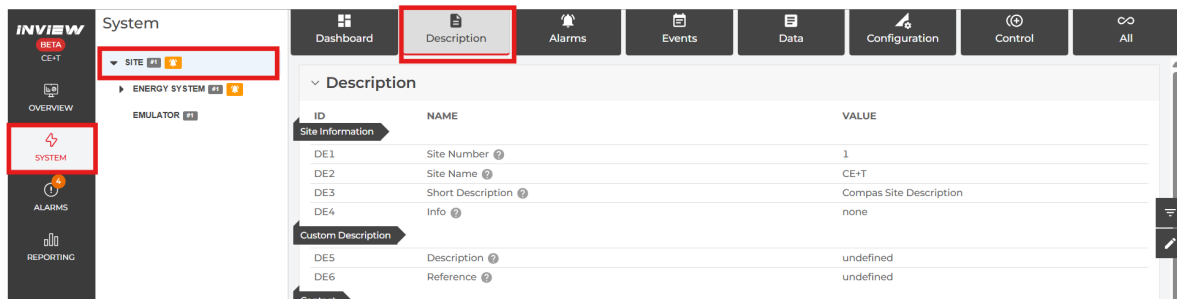

| ID                        | NAME              | VALUE                   |
|---------------------------|-------------------|-------------------------|
| <b>Site Information</b>   |                   |                         |
| DE1                       | Site Number       | 1                       |
| DE2                       | Site Name         | CE+T                    |
| DE3                       | Short Description | Compas Site Description |
| DE4                       | Info              | none                    |
| <b>Custom Description</b> |                   |                         |
| DE5                       | Description       | undefined               |
| DE6                       | Reference         | undefined               |

### 7.3.2 Date and Time Settings

Navigate to *ADMINISTRATION > Time Management*.

- **Update with Computer time:** Inview read the laptop time during the configuration and adapt that time.
- **Update with NTP:** Inview Internal clock synchronizes with the server time.

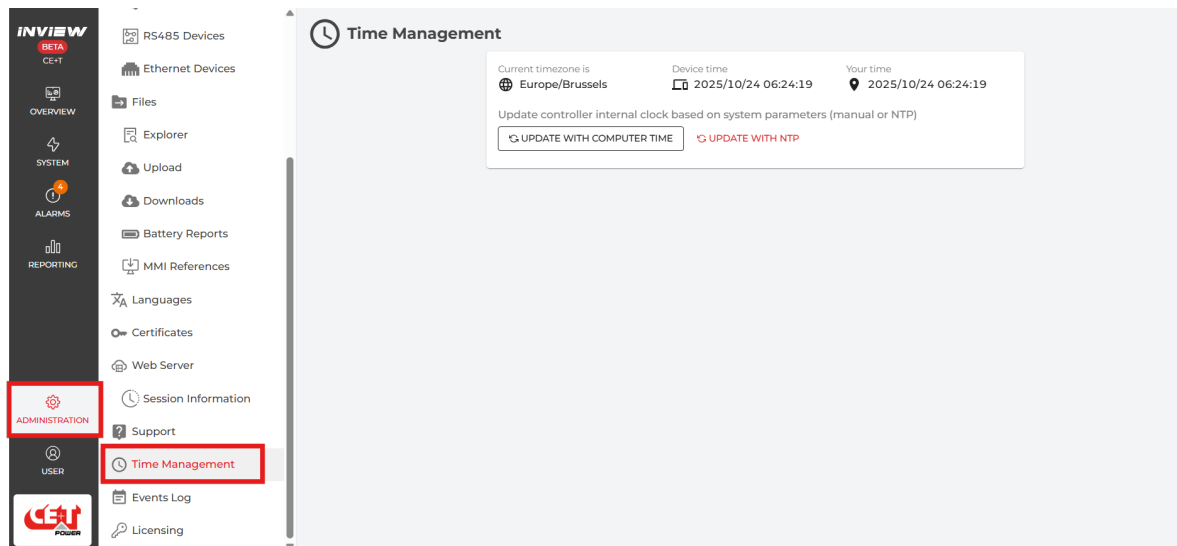

### 7.3.3 Network Settings

Navigate to *SYSTEM > SITE > Configuration*

Enter the **Network** details such as *IP address, Firewall settings, authentication controls, web server,* and applicable parameters.

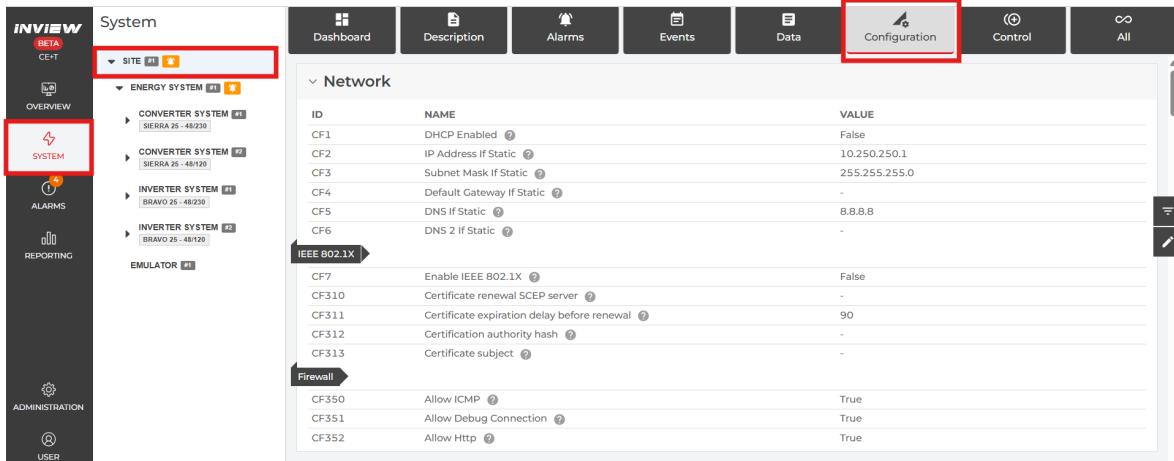

| ID                 | NAME                                        | VALUE         |
|--------------------|---------------------------------------------|---------------|
| CF1                | DHCP Enabled                                | False         |
| CF2                | IP Address If Static                        | 10.250.250.1  |
| CF3                | Subnet Mask If Static                       | 255.255.255.0 |
| CF4                | Default Gateway If Static                   | -             |
| CF5                | DNS If Static                               | 8.8.8.8       |
| CF6                | DNS 2 If Static                             | -             |
| <b>IEEE 802.1X</b> |                                             |               |
| CF7                | Enable IEEE 802.1X                          | False         |
| CF310              | Certificate renewal SCEP server             | -             |
| CF311              | Certificate expiration delay before renewal | 90            |
| CF312              | Certification authority hash                | -             |
| CF313              | Certificate subject                         | -             |
| <b>Firewall</b>    |                                             |               |
| CF350              | Allow ICMP                                  | True          |
| CF351              | Allow Debug Connection                      | True          |
| CF352              | Allow Http                                  | True          |

### 7.4 System Configuration

To configure the converter systems, navigate to *SYSTEM > SITE > ENERGY SYSTEM > CONVERTER SYSTEM > Configuration*.

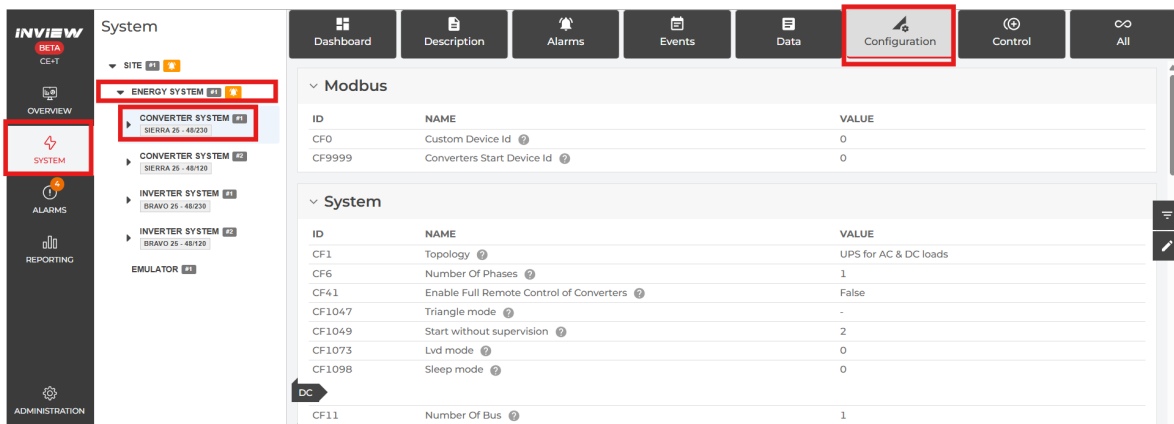

| ID     | NAME                       | VALUE |
|--------|----------------------------|-------|
| CF0    | Custom Device Id           | 0     |
| CF9999 | Converters Start Device Id | 0     |

| ID        | NAME                                     | VALUE                 |
|-----------|------------------------------------------|-----------------------|
| CF1       | Topology                                 | UPS for AC & DC loads |
| CF6       | Number Of Phases                         | 1                     |
| CF41      | Enable Full Remote Control of Converters | False                 |
| CF1047    | Triangle mode                            | -                     |
| CF1049    | Start without supervision                | 2                     |
| CF1073    | Lvd mode                                 | 0                     |
| CF1098    | Sleep mode                               | 0                     |
| <b>DC</b> |                                          |                       |
| CF11      | Number Of Bus                            | 1                     |

### 7.4.1 Topology Selection

Navigate to *SYSTEM > SITE > ENERGY SYSTEM > CONVERTER SYSTEM > Configuration > System*.  
In System section ID CF1, select the topology from the drop-down list based upon the system design.

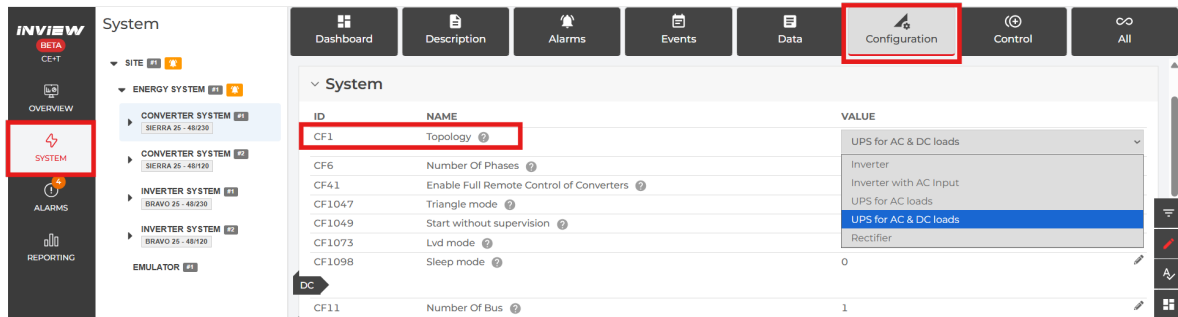

After selecting the topology, scroll down to *DC > Modes* section on the same page and set the ID CF1071 to "0" or "1" as per in the following table.

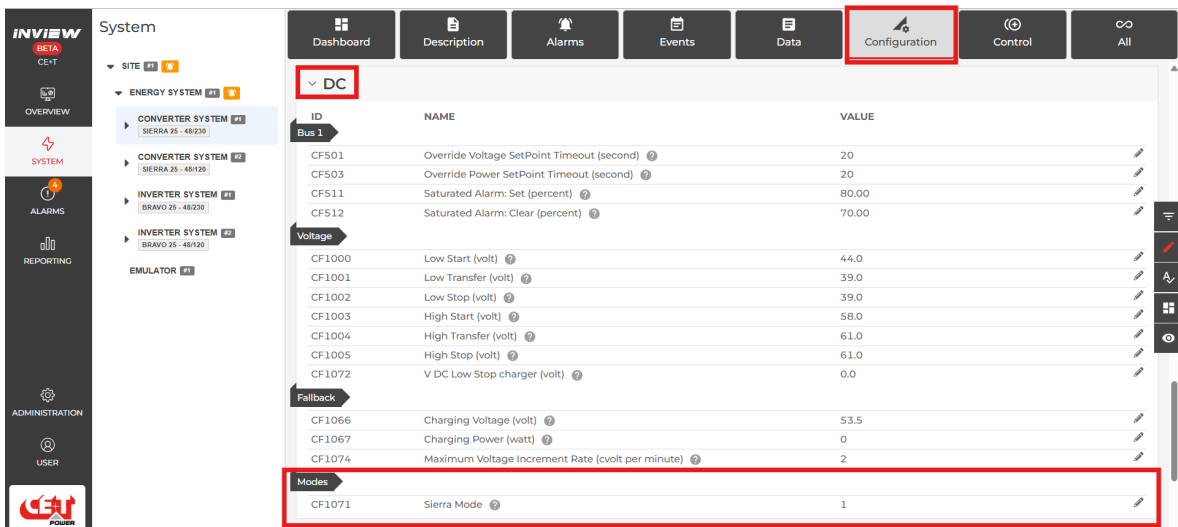

| Topology CF1                      | Supported Modules    | Input     | Output                       | Parameter ID CF1071 | Parameter ID CF1066 | Parameter ID CF1067 | Parameter ID CF1074 |
|-----------------------------------|----------------------|-----------|------------------------------|---------------------|---------------------|---------------------|---------------------|
| Inverter (REG DC / AC only)       | Bravo 25 and 10      | DC        | AC load                      | 0                   | NA                  | NA                  | NA                  |
| Inverter with AC Input (EPC mode) | Bravo 25 and 10      | AC and DC | AC load                      | 0                   | NA                  | NA                  | NA                  |
| UPS for AC loads                  | Sierra 10, 25 and XC | AC and DC | AC load and battery charging | 1                   | Fall back mode 1    | Fallback mode 1     | Fallback mode 1     |

| Topology CF1            | Supported Modules    | Input     | Output                             | Parameter ID CF1071 | Parameter ID CF1066 | Parameter ID CF1067 | Parameter ID CF1074 |
|-------------------------|----------------------|-----------|------------------------------------|---------------------|---------------------|---------------------|---------------------|
| UPS for AC and DC loads | Sierra 10, 25 and XC | AC and DC | AC & DC load, and battery charging | 1                   | Fallback mode 2     | Fallback mode 2     | Fallback mode 2     |
| Rectifier               | Sierra 10, 25 and XC | AC and DC | DC Load and battery charging       | 1                   | Fallback mode 2     | Fallback mode 2     | Fallback mode 2     |

## 7.4.2 Fallback mode

This mode will be activated when the modules lose communication with Inview. There are two modes available depending on the kind of system. Navigate to [SITE > ENERGY SYSTEM > CONVERTER SYSTEM > Configuration](#), Scroll down to section [Fallback](#).

### Fallback mode 1:

- **CF1 Topology:**
  - UPS for AC loads
- **CF1066 Charging Voltage:**
  - Configure the voltage required on the DC port in fallback mode. Since the modules do not calculate temperature compensation once communication between the Inview controller and the module is lost. Consider the float voltage at the worst operating scenario.
- **CF1067 Charging Power:**
  - Maximum charging power is required for batteries in fallback mode. Set it according to the datasheet of the connected battery manufacturer.
- **CF1074 Max VDC Increment:**
  - By default, set it to 0. It doesn't have to be used for UPS for AC loads.

### Fallback mode 2:

- **CF1 Topology:**
  - UPS for AC & DC loads or Rectifier is set
- **CF1066 Charging Voltage:**
  - Configure the voltage required on DC port in fallback mode. Since the modules do not calculate temperature compensation once communication between the Inview controller and the module is lost. Consider the float voltage at the worst operating scenario.
- **CF1067 Charging Power:**
  - Set the charging power to the maximum power required for charging the battery + Maximum power required for the connected DC load. If the power limit is unknown, set this value to the maximum power capacity of the system so that the DC loads are powered up at any time. **CF1074 Max VDC Increment:**
  - Voltage increment is used to recharge the battery in cV/min. Ensures the battery's maximum charging power is limited in fallback mode.
  - If the voltage has to increase rapidly, you can change this value.

For example, configuring it to '6' will increase the DC port voltage to a maximum of 3.6V per hour.

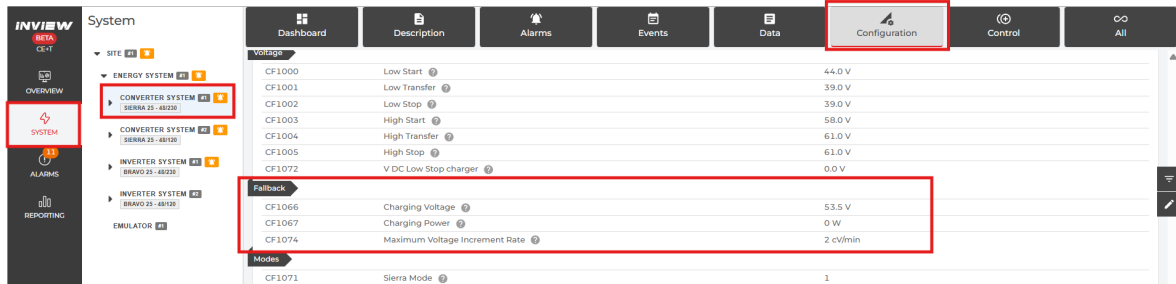

### 7.4.3 Phase Selection

To configure the Single, Dual or Three phase of the system, navigate to *SITE > ENERGY SYSTEM > CONVERTER SYSTEM > Configuration*.

In the System section ID CF6, enter the number of phases based upon the system input/output power.

*(Note: while configuring the AC phases, all the converters should be in OFF mode)*

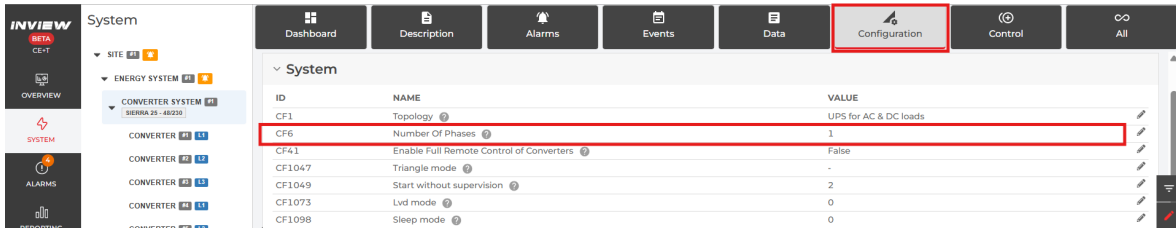

### 7.4.4 AC Output Configuration

To configure AC output parameters, navigate to *SITE > ENERGY SYSTEM > CONVERTER SYSTEM > Configuration*.

In the AC Outputs section, enter the values for the corresponding parameter ID:

- ID CF121: enter the number of converters configured for phase 1 (Installed power)
- ID CF122: enter the number of converters redundant for phase 1 (Available power)
- ID CF123: enter the phase shift degree for phase 1
- Similarly, enter the values for phase 2 and 3
- ID CF1016: enter the nominal frequency

*(Note: while configuring the AC phases, the converter should be in OFF mode)*

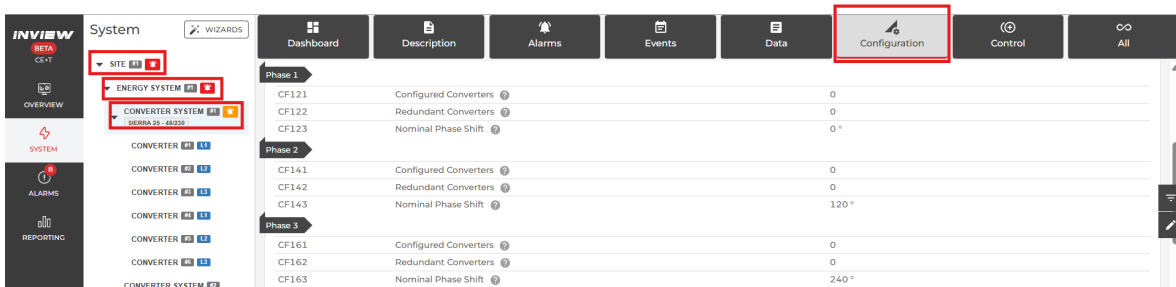

### 7.4.5 Converters Configuration

If the system has more than one converter, it is better to start configuring with one converter on each phase.

1. Insert only one converter in the first phase of the system.  
Navigate to *SITE > ENERGY SYSTEM > CONVERTER SYSTEM > CONVERTER > Control > Global*.

(Note: while assigning the phases of the converter, its AC output must be in OFF)

- I) Execute the ID CT12, to turn off the converter
- II) In the ID CT2, type “1” to set the converter ID and in the ID CT13 as “1” to assign phase 1
- III) After setting the values, click the  icon to execute that command

In this page, you can turn on/off the module or AC output and DC port of the module.

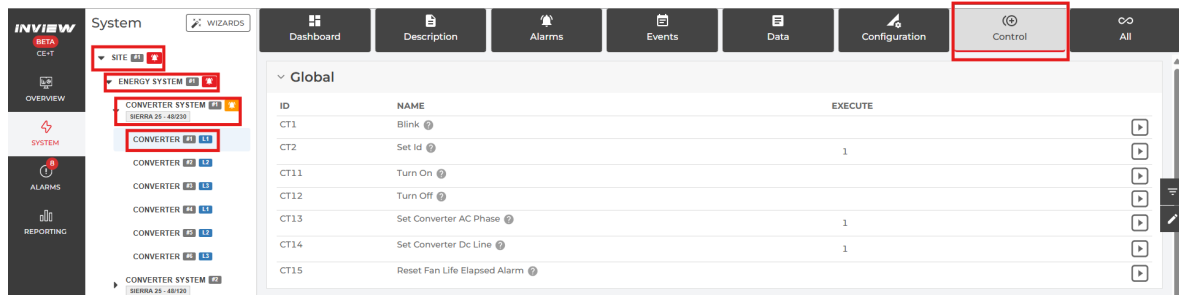

To get an overview of the converter details, go to *SITE > ENERGY SYSTEM > CONVERTER SYSTEM > CONVERTER > Dashboard*.

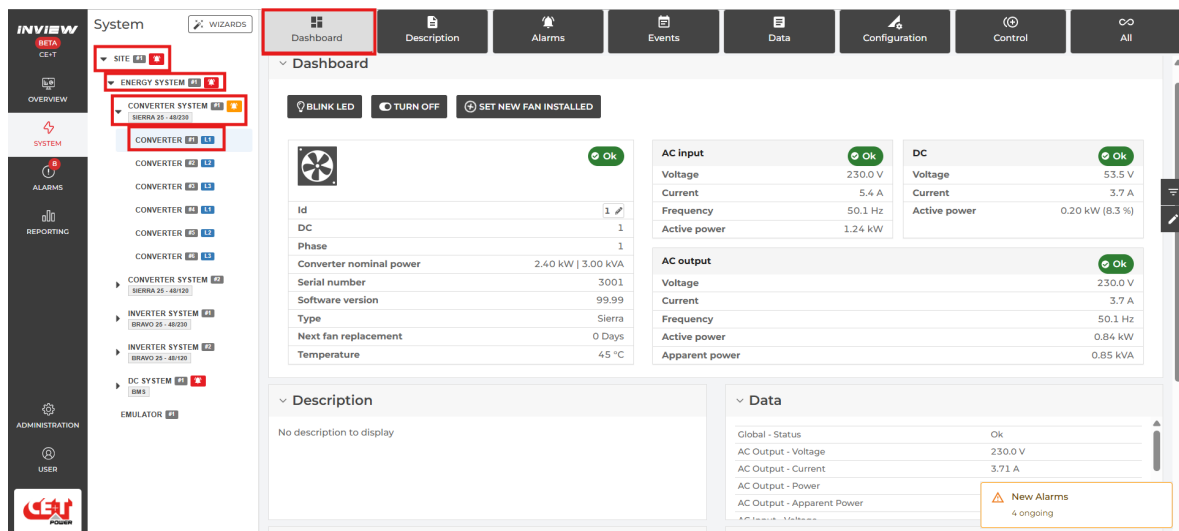

In this page also you can modify the converter ID and Phase number.

**Other Features:**

- **Blink LED:** Clicking on “BLINK LED” button, the corresponding converter LED’s blink for 6 seconds. It helps to identify the converter in the system and also the assigned phase of the converter.
- **Turn Off:** Clicking on “TURN OFF” button, the corresponding converter will be turned OFF and generates an alarm in events page as converter off.
- **Set new fan installed:** Clicking on “SET NEW FAN INSTALLED” button, the corresponding converter “Module fan replacement” due will be reset to 2556 days (7 years).

*Note: Do not click this button, until a new fan is replaced inside the converter.*

2. If it is a single-phase system, insert the remaining converters and set module ID and assign them to phase 1.

*Note: Perform the following procedure for the multiphase system*

3. Insert the second converter in phase 2, and set the Converter ID as “2,” and assign it “Phase 2”
4. Insert the third converter in phase 3, and set the Converter ID as “3,” and assign it “Phase 3.”
5. Repeat the process for remaining converters by adding one converter in each phase.
6. After configuring all the converters, turn ON all the converters.

To turn on all the converters, navigate to *SITE > ENERGY SYSTEM > CONVERTER SYSTEM > CONVERTER > Control and execute CT41 parameter.*

### 7.4.6 DC Configuration

Navigate to *SYSTEM > SITE > ENERGY SYSTEM > DC SYSTEM > Configuration.*

In the DC Bus section, set the parameters depending upon the DC voltage. The below page is configured to 48 Vdc.

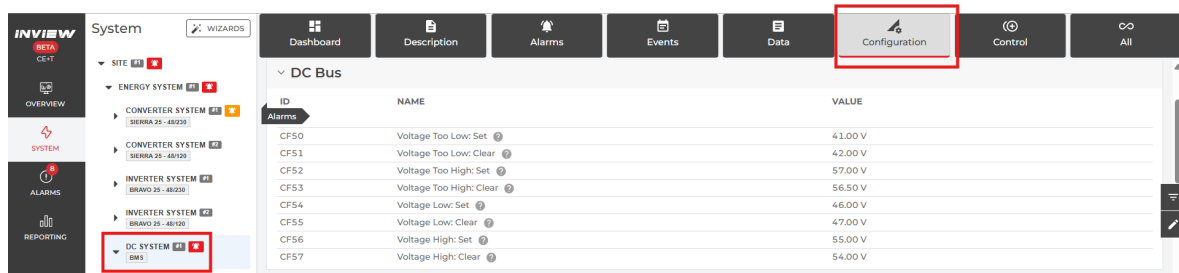

| ID   | NAME                    | VALUE   |
|------|-------------------------|---------|
| CF50 | Voltage Too Low: Set    | 41.00 V |
| CF51 | Voltage Too Low: Clear  | 42.00 V |
| CF52 | Voltage Too High: Set   | 57.00 V |
| CF53 | Voltage Too High: Clear | 56.50 V |
| CF54 | Voltage Low: Set        | 46.00 V |
| CF55 | Voltage Low: Clear      | 47.00 V |
| CF56 | Voltage High: Set       | 55.00 V |
| CF57 | Voltage High: Clear     | 54.00 V |

## 7.5 Battery Configuration

The battery page provides access and configures battery parameters such as battery characteristics, LVD, temperature compensation, boost charging, and test.

Battery configuration page is applicable only for the following topology designed system.

- UPS for AC loads
- UPS for AC and DC loads

Make sure the ID CF1071 is set as “1” to configure Sierra converter. (Access to CF1071: *SYSTEM > SITE > ENERGY SYSTEM > CONVERTER SYSTEM > Configuration* , scroll down to DC > Modes)

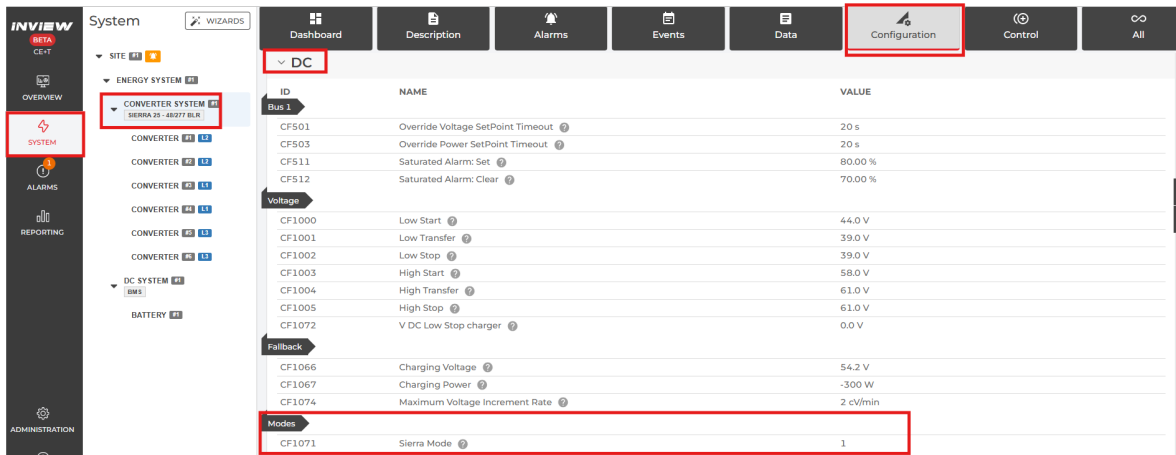

| ID              | NAME                              | VALUE    |
|-----------------|-----------------------------------|----------|
| <b>Bus 1</b>    |                                   |          |
| CF501           | Override Voltage SetPoint Timeout | 20 s     |
| CF503           | Override Power SetPoint Timeout   | 20 s     |
| CF511           | Saturated Alarm: Set              | 80.00 %  |
| CF512           | Saturated Alarm: Clear            | 70.00 %  |
| <b>Voltage</b>  |                                   |          |
| CF1000          | Low Start                         | 44.0 V   |
| CF1001          | Low Transfer                      | 39.0 V   |
| CF1002          | Low Stop                          | 39.0 V   |
| CF1003          | High Start                        | 58.0 V   |
| CF1004          | High Transfer                     | 61.0 V   |
| CF1005          | High Stop                         | 61.0 V   |
| CF1072          | V DC Low Stop charger             | 0.0 V    |
| <b>Fallback</b> |                                   |          |
| CF1066          | Charging Voltage                  | 54.2 V   |
| CF1067          | Charging Power                    | -300 W   |
| CF1074          | Maximum Voltage Increment Rate    | 2 cV/min |
| <b>Modes</b>    |                                   |          |
| CF1071          | Sierra Mode                       | 1        |

Navigate to *SYSTEM > SITE > ENERGY SYSTEM > CONVERTER SYSTEM > Configuration*.

In the Battery section, enter the details of the battery connected to the system such as Battery characteristics, Measurement source, Autonomy and Temperature Alarms.

**Note:** In this page, the parameters are configured with default values. While modifying the parameters, it is recommended to enter the values as per the system DC voltage and battery datasheet.

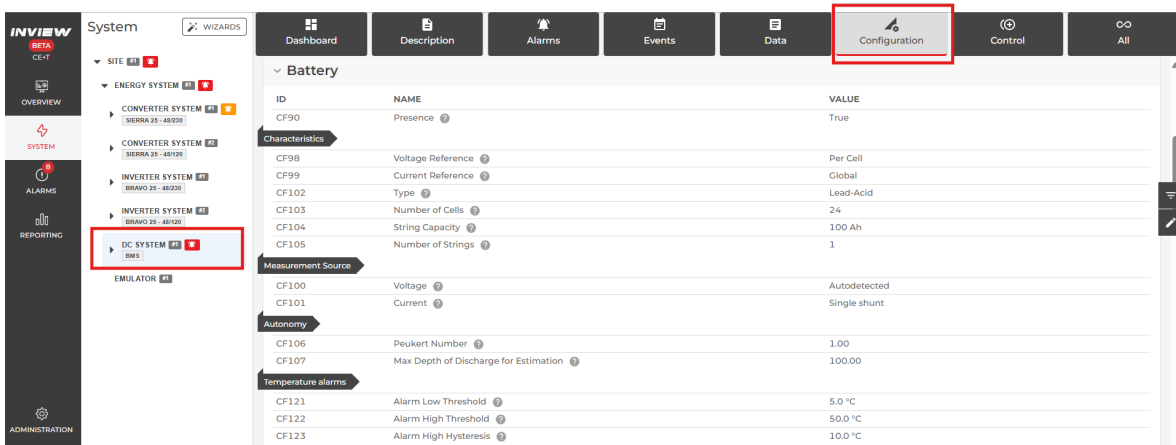

| ID                        | NAME                                  | VALUE        |
|---------------------------|---------------------------------------|--------------|
| CF90                      | Presence                              | True         |
| <b>Characteristics</b>    |                                       |              |
| CF98                      | Voltage Reference                     | Per Cell     |
| CF99                      | Current Reference                     | Global       |
| CF102                     | Type                                  | Lead-Acid    |
| CF103                     | Number of Cells                       | 24           |
| CF104                     | String Capacity                       | 100 Ah       |
| CF105                     | Number of Strings                     | 1            |
| <b>Measurement Source</b> |                                       |              |
| CF100                     | Voltage                               | Autodetected |
| CF101                     | Current                               | Single shunt |
| <b>Autonomy</b>           |                                       |              |
| CF106                     | Peukert Number                        | 1.00         |
| CF107                     | Max Depth of Discharge for Estimation | 100.00       |
| <b>Temperature alarms</b> |                                       |              |
| CF121                     | Alarm Low Threshold                   | 5.0 °C       |
| CF122                     | Alarm High Threshold                  | 50.0 °C      |
| CF123                     | Alarm High Hysteresis                 | 10.0 °C      |

### 7.5.1 Measurement Source

Select any one option for dashboard voltage and current based upon the battery source in the ID CF100 and CF101, respectively.

- *Auto Detected*: It detects automatically based upon the voltage and current measurement
- Select “*Single probe*”, if MBB measures the DC values
- Select “*Modules*”, if MBB is not installed
- Select “*Smart Batteries*”, if BMS of the battery measures the DC values

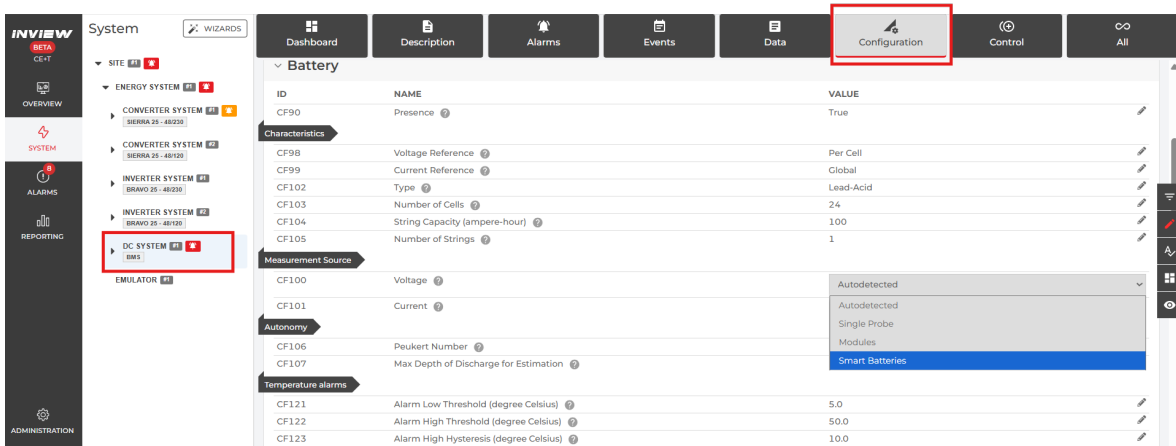

| ID                        | NAME                                   | VALUE        |
|---------------------------|----------------------------------------|--------------|
| CF90                      | Presence                               | True         |
| <b>Characteristics</b>    |                                        |              |
| CF98                      | Voltage Reference                      | Per Cell     |
| CF99                      | Current Reference                      | Global       |
| CF102                     | Type                                   | Lead-Acid    |
| CF103                     | Number of Cells                        | 24           |
| CF104                     | String Capacity (ampere-hour)          | 100          |
| CF105                     | Number of Strings                      | 1            |
| <b>Measurement Source</b> |                                        |              |
| CF100                     | Voltage                                | Autodetected |
| CF101                     | Current                                | Autodetected |
| <b>Autonomy</b>           |                                        |              |
| CF106                     | Peukert Number                         |              |
| CF107                     | Max Depth of Discharge for Estimation  |              |
| <b>Temperature alarms</b> |                                        |              |
| CF121                     | Alarm Low Threshold (degree Celsius)   | 5.0          |
| CF122                     | Alarm High Threshold (degree Celsius)  | 50.0         |
| CF123                     | Alarm High Hysteresis (degree Celsius) | 10.0         |

### 7.5.2 Battery Disconnect or LVD

The LVD in the CE+T system prevents batteries from discharging beyond the threshold voltage. It is installed in-line between the load and the battery. On this page, the parameters are configured with default values. Users can modify it as per the LVD installed in the system.

Navigate to **SYSTEM > SITE > ENERGY SYSTEM > DC SYSTEM > Configuration**.

In the *Battery Disconnect* section, enter the details of LVD connected to the system.

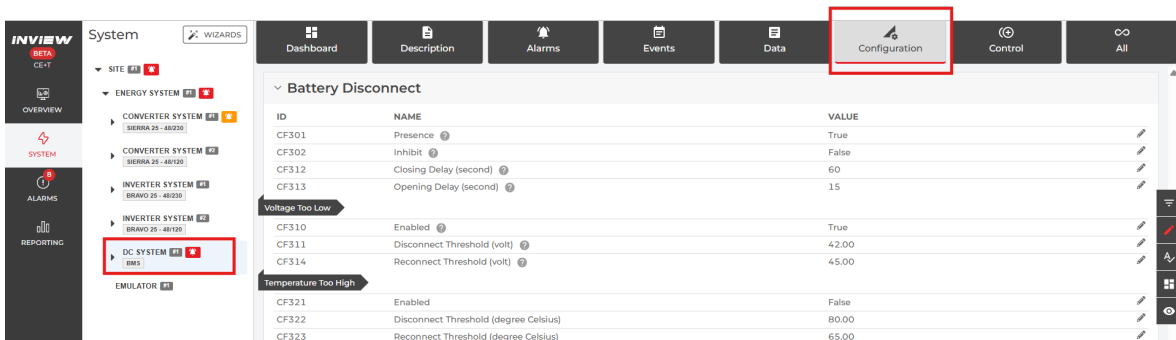

| ID                          | NAME                                  | VALUE |
|-----------------------------|---------------------------------------|-------|
| CF301                       | Presence                              | True  |
| CF302                       | Inhibit                               | False |
| CF312                       | Closing Delay (second)                | 60    |
| CF313                       | Opening Delay (second)                | 15    |
| <b>Voltage Too Low</b>      |                                       |       |
| CF310                       | Enabled                               | True  |
| CF311                       | Disconnect Threshold (volt)           | 42.00 |
| CF314                       | Reconnect Threshold (volt)            | 45.00 |
| <b>Temperature Too High</b> |                                       |       |
| CF321                       | Enabled                               | False |
| CF322                       | Disconnect Threshold (degree Celsius) | 80.00 |
| CF323                       | Reconnect Threshold (degree Celsius)  | 65.00 |

Refer to the section “Relay Configuration”, page 51 for further LVD relay/shunt settings.

## 7.6 Sensors and Actuators

The Sensors and Actuators page contains details of external devices such as MBB 60V / MBB 500V, which are connected through CANBUS, Ethernet or RS485.

Navigate to **SYSTEM > SITE > SENSORS AND ACTUATORS > Dashboard** and set the ID as “MBB -1”.

*Note: If a new MBB is replaced, clear the old MBB from the list by clicking “Clean Equipment Inventory”.*

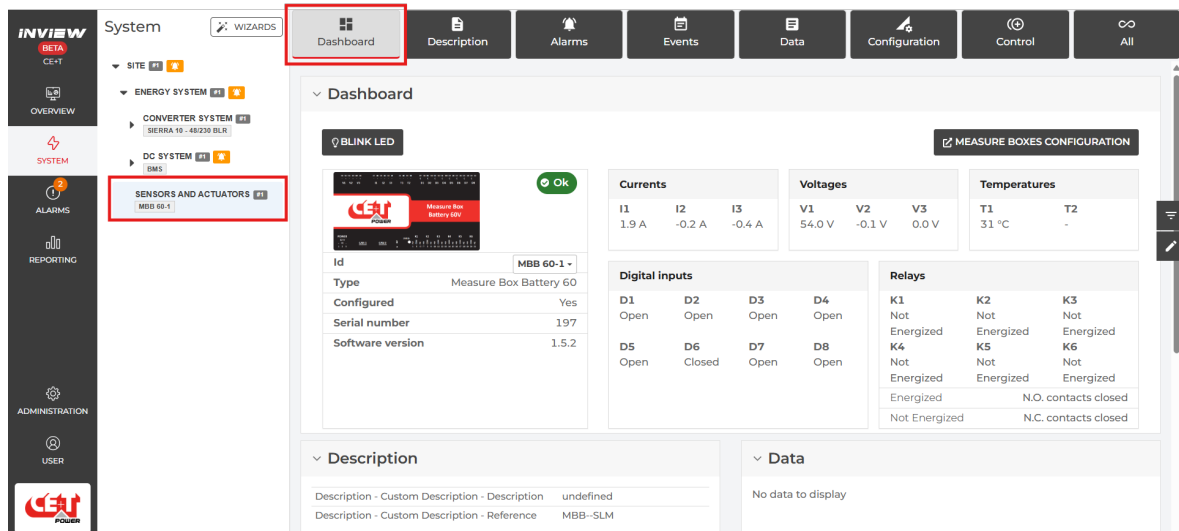

The screenshot displays the 'SENSORS AND ACTUATORS' dashboard for device 'MBB 60-1'. The dashboard includes several monitoring panels: 'BLINK LED' (Ok), 'MEASURE BOXES CONFIGURATION', 'Currents' (I1: 1.9 A, I2: -0.2 A, I3: -0.4 A), 'Voltages' (V1: 54.0 V, V2: -0.1 V, V3: 0.0 V), 'Temperatures' (T1: 31 °C, T2: -), 'Digital inputs' (D1-D8), and 'Relays' (K1-K6). A table at the bottom shows 'Description' and 'Data' sections.

To clear the old MBB 60V / MBB 500V, navigate to **SYSTEM > SITE > Control**, scroll down to the **Inventory** section. In the ID CT61 (Clean Equipment Inventory), click the  icon to clear it from the list.

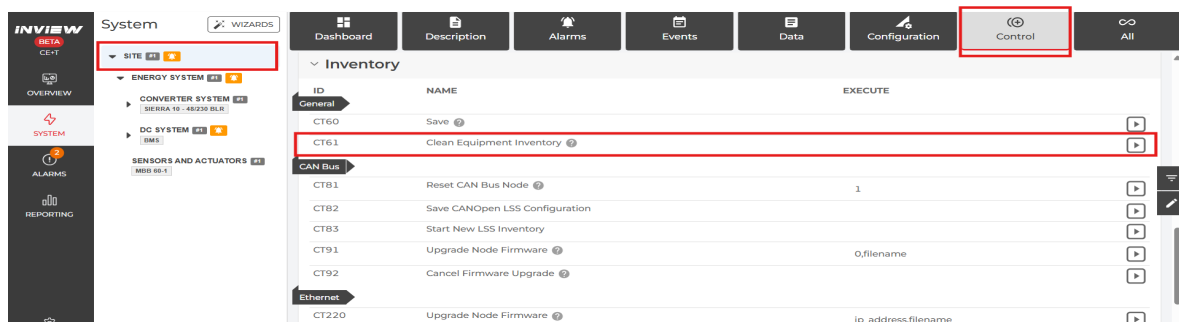

The screenshot shows the 'Inventory' section under the 'Control' menu. The 'Inventory' table lists various actions with their IDs and names. The 'Clean Equipment Inventory' row (ID: CT61) is highlighted with a red box, and its corresponding red square icon is also highlighted.

| ID              | NAME                           | EXECUTE             |
|-----------------|--------------------------------|---------------------|
| CT60            | Save                           |                     |
| CT61            | Clean Equipment Inventory      |                     |
| <b>CAN Bus</b>  |                                |                     |
| CT81            | Reset CAN Bus Node             | 1                   |
| CT82            | Save CANOpen LSS Configuration |                     |
| CT83            | Start New LSS Inventory        |                     |
| CT91            | Upgrade Node Firmware          | 0,filename          |
| CT92            | Cancel Firmware Upgrade        |                     |
| <b>Ethernet</b> |                                |                     |
| CT220           | Upgrade Node Firmware          | ip_address,filename |

### 7.6.1 MBB Configuration

Before configuring MBB, navigate to **SYSTEM > SITE > ENERGY SYSTEM > DC SYSTEM > Configuration > Battery** and in the **Measurement Source** section, make sure the ID CF100 is set to “Single probe” and ID CF101 to “Single shunt”.

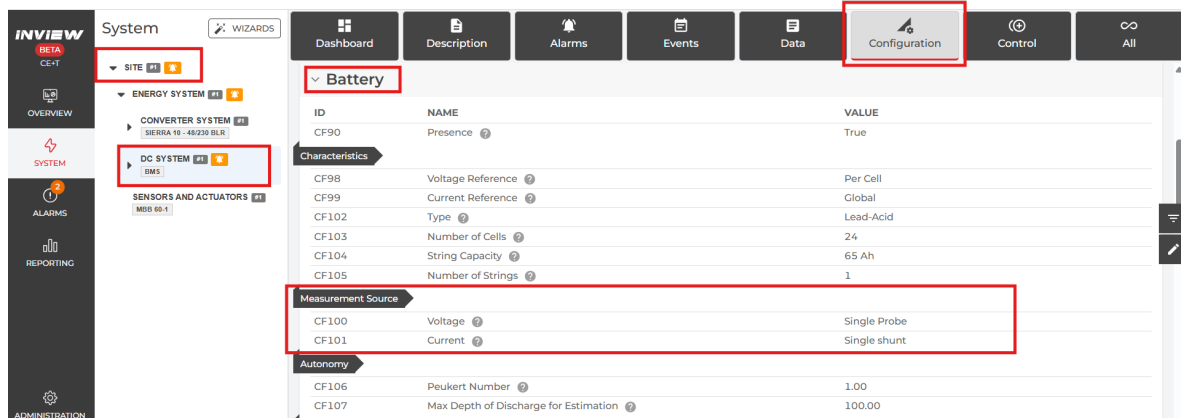

| ID                        | NAME                                  | VALUE        |
|---------------------------|---------------------------------------|--------------|
| CF90                      | Presence                              | True         |
| <b>Characteristics</b>    |                                       |              |
| CF98                      | Voltage Reference                     | Per Cell     |
| CF99                      | Current Reference                     | Global       |
| CF102                     | Type                                  | Lead-Acid    |
| CF103                     | Number of Cells                       | 24           |
| CF104                     | String Capacity                       | 65 Ah        |
| CF105                     | Number of Strings                     | 1            |
| <b>Measurement Source</b> |                                       |              |
| CF100                     | Voltage                               | Single Probe |
| CF101                     | Current                               | Single shunt |
| <b>Autonomy</b>           |                                       |              |
| CF106                     | Peukert Number                        | 1.00         |
| CF107                     | Max Depth of Discharge for Estimation | 100.00       |

To configure MBB, navigate to **SYSTEM > SITE > SENSORS AND ACTUATORS > Configuration**.

- Voltage section:** select an option for the V1, V2 and V3 from the drop-down list in the ID CF101, CF106, and CF111, respectively.

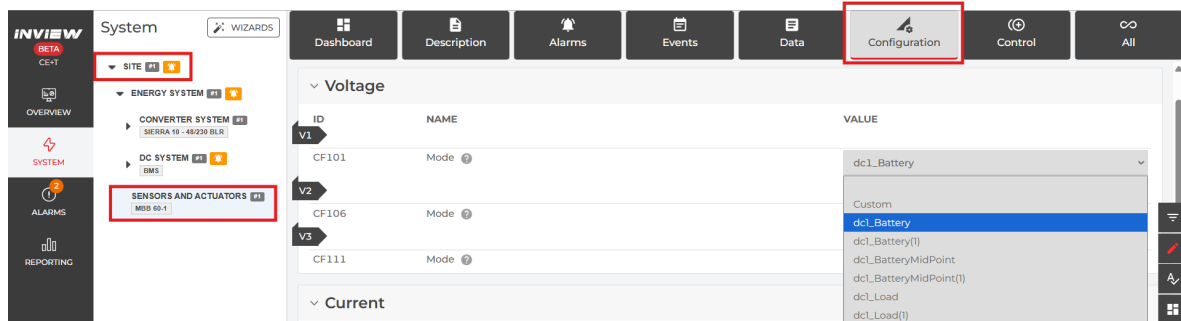

| ID             | NAME | VALUE       |
|----------------|------|-------------|
| V1             |      |             |
| CF101          | Mode | dc1_Battery |
| V2             |      |             |
| CF106          | Mode | dc1_Battery |
| V3             |      |             |
| CF111          | Mode | dc1_Battery |
| <b>Current</b> |      |             |

- **dc1\_Load:** to measure voltage of DC load
- **dc1\_Battery:** to measure the voltage of battery
- **dc1\_BatteryMidPoint:** to measure the DC voltage between the batteries midpoint by using V2 and V3

- Current section:** select an option for the I1, I2 and I3 from the drop-down list in the ID CF201, CF206 and CF211, respectively.

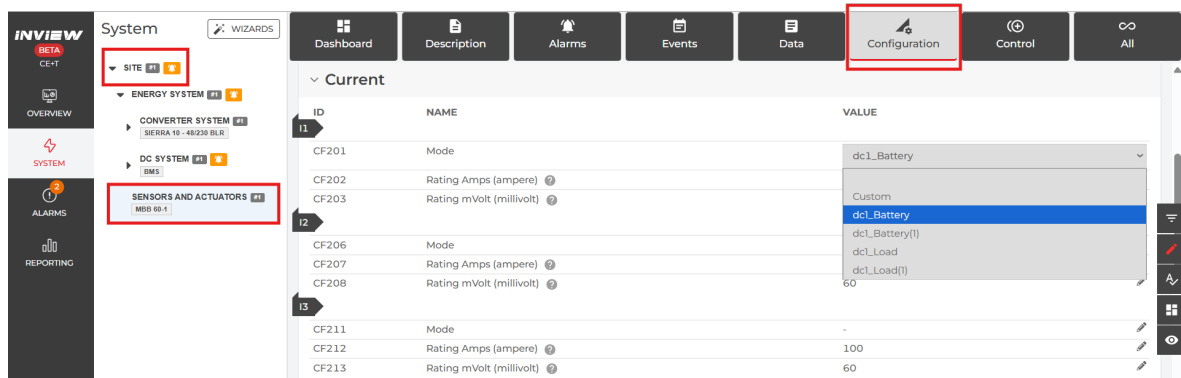

| ID    | NAME                     | VALUE       |
|-------|--------------------------|-------------|
| I1    |                          |             |
| CF201 | Mode                     | dc1_Battery |
| CF202 | Rating Amps (ampere)     |             |
| CF203 | Rating mVolt (millivolt) |             |
| I2    |                          |             |
| CF206 | Mode                     | dc1_Battery |
| CF207 | Rating Amps (ampere)     |             |
| CF208 | Rating mVolt (millivolt) | 60          |
| I3    |                          |             |
| CF211 | Mode                     |             |
| CF212 | Rating Amps (ampere)     | 100         |
| CF213 | Rating mVolt (millivolt) | 60          |

- **dc1\_Load**: to measure the current of DC load
  - **dc1\_Battery**: to measure the current of battery
  - Enter the corresponding rating values of shunt
3. **Temperature section**: select an option for the T1 and T2 from the drop-down list in the ID CF301 and CF306, respectively.

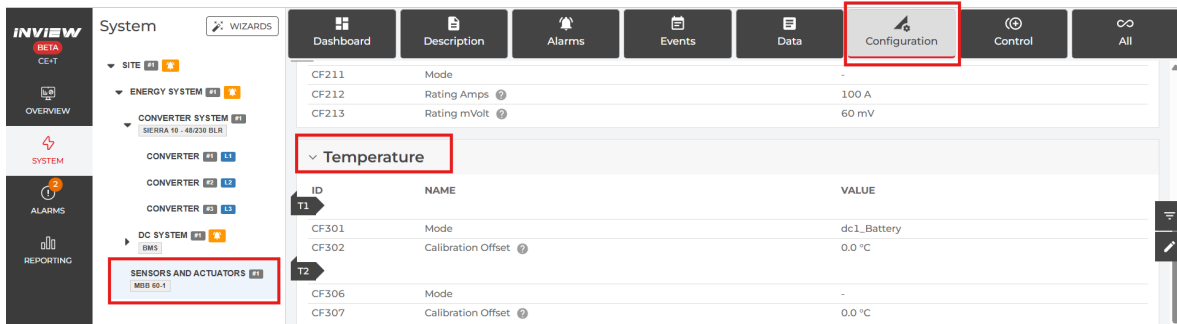

- **dc1\_Battery**: to measure the temperature of battery
  - **dc1\_Ambient**: to measure the ambient temperature of battery
4. **Relay Configuration**: The MBB has six (MBB 60V) and four (MBB 500V) relays and configured as below:
- K1 and K2 are configured to Minor and Major alarms if used.
  - K3 and K4 can be configured to any desired alarms or digital inputs if used (not applicable for MBB 500V)

**Example: Assigning a relay to the digital input**

- Go to K3 relay and select the following options
- ID CF411: select the mode as “Custom”
- ID CF412: select the Default state as “Energized” or “De-energized”
- ID CF413: enter the formula as “@(sa1\_data501)”

(Sa1: Sensors and Actuators, data501: Data section, Digital input D1 (DA501))

- After selecting the options, click “APPLY AND SAVE” in the modification list.

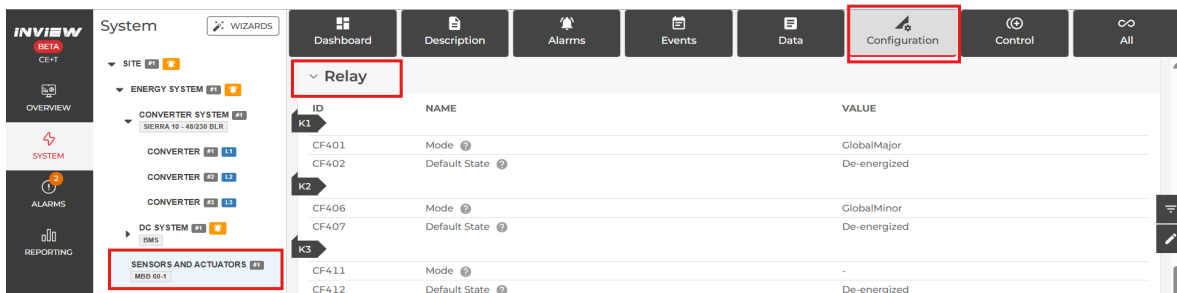

- K5 and K6 are configured to latch or non-latch LVD, if used

- **Relay section:** select an option for K5 and K6 from “Mode” drop down list
- For latch LVD, select the ID CF421 as “dc1\_LvdLatchClose” and CF426 as “dc1\_LvdLatchOpen” or vice versa, but must not assign the same value for both relays.
- For non-latch LVD, select the ID CF421 as “dc1\_Lvd”
- Select Default State as “De-energized”

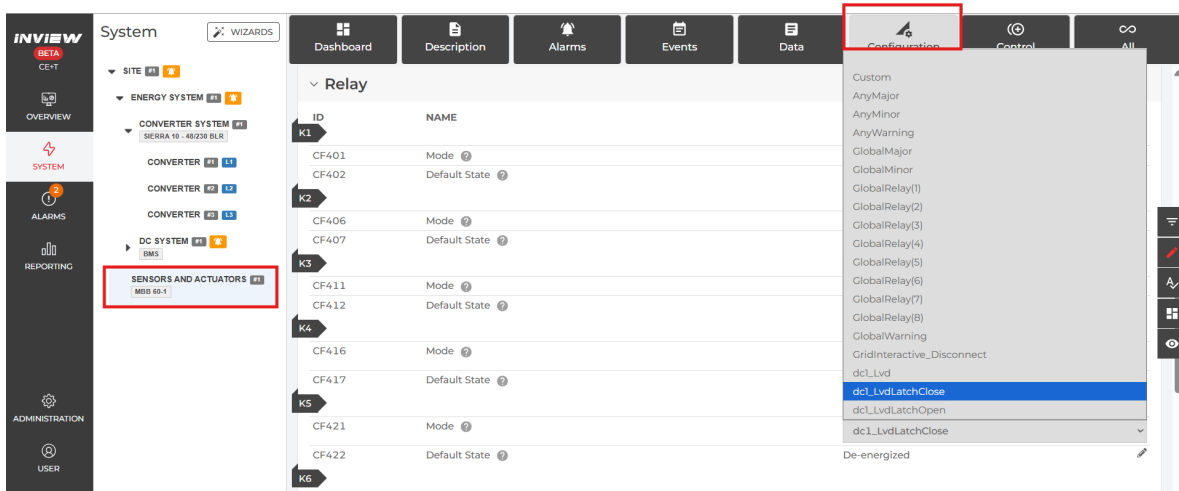

5. **Digital Inputs:** To know LVD status, connect the auxiliary contact to the Digital Input 6. The ID CF526 is to select as “dc1\_LvdState”

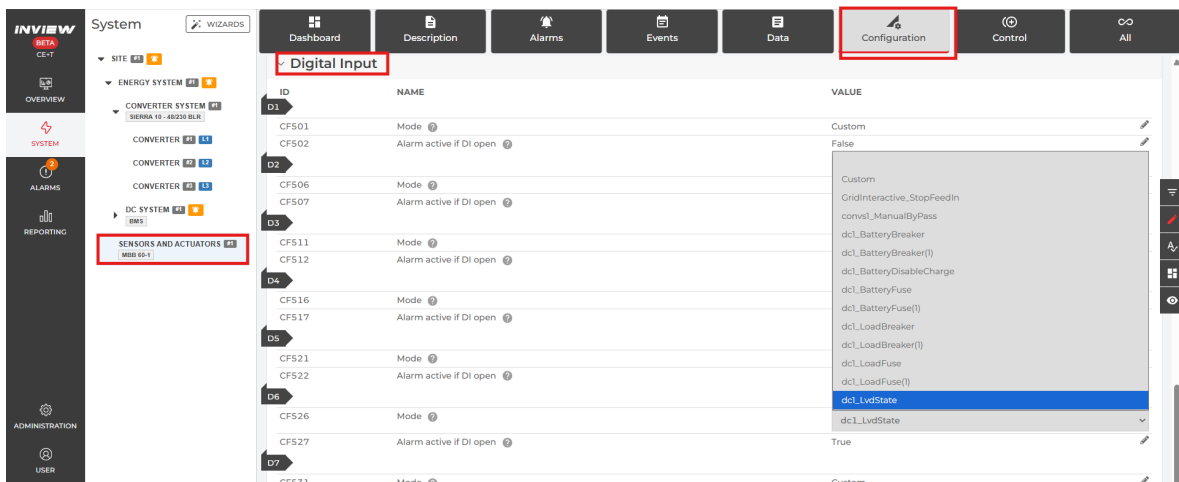

The below connection diagram is an example of LVD Auxiliary contact.

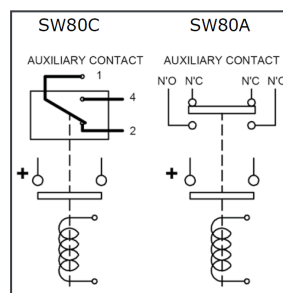

## 7.7 Manual Bypass Configuration

The manual by-pass is a manually operated switch, and it is used to transfer the load from normal to by-pass without interruption. When the system is in by-pass, the load is subjected to AC main disturbances. The standard manual by-pass is “Make before Break”. The MBP auxiliary contact must be connected to the Inview Digital input 1.

Navigate to **SYSTEM > SITE > Configuration** and scroll down to the **Digital Input** section. In the ID CF501, select the “*convst1\_ManualByPass*” from the drop down list.

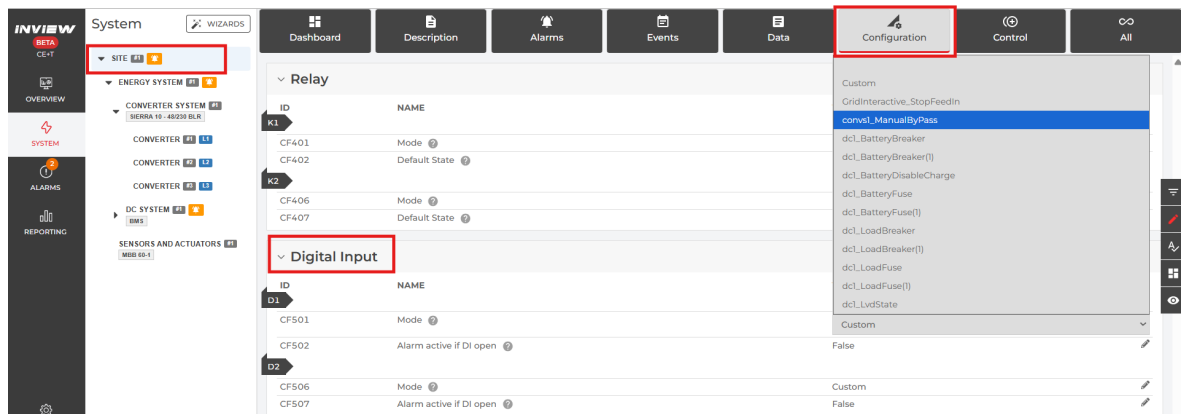

The screenshot shows the Inview web interface. The left sidebar has 'SYSTEM' selected. The main content area is 'Configuration'. Under 'Digital Input', there is a table with columns 'ID' and 'NAME'. The row for ID CF501 is selected, and a dropdown menu is open, showing 'convst1\_ManualByPass' as the selected option. Other options include 'Custom', 'GridInteractive\_StopFeedIn', 'dcl\_BatteryBreaker', 'dcl\_BatteryBreaker()', 'dcl\_BatteryDisableCharge', 'dcl\_BatteryFuse', 'dcl\_BatteryFuse()', 'dcl\_LoadBreaker', 'dcl\_LoadBreaker()', 'dcl\_LoadFuse', 'dcl\_LoadFuse()', 'dcl\_LvdState', and 'dcl\_LvdState()'.

*Note: For more information about MBP auxiliary connection with remote ON/OFF, refer to the system user manual.*

## 7.8 Module Remote ON/OFF

The AC and DC output of the system and also each module in the system can be turned ON/OFF in two ways:

1. Remote ON/OFF terminal at rear side of the shelf or on a junction kit for Sierra XC parallelization: will impact only AC output.
2. Through web interface:
  - System Level
    - Both AC and DC: **SITE > CONVERTER SYSTEM > Control > System** section > CT41 and CT42
    - AC Only: **SITE > CONVERTER SYSTEM > Control > AC Outputs** section > CT101 and CT102
    - DC Only: **SITE > CONVERTER SYSTEM > Control > DC** section > CT511 and CT512

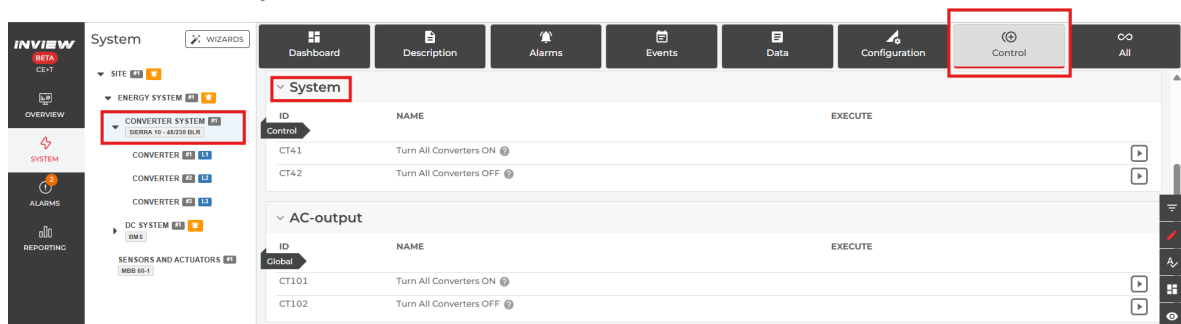

The screenshot shows the Inview web interface. The left sidebar has 'SYSTEM' selected. The main content area is 'Control'. Under 'System', there is a table with columns 'ID', 'NAME', and 'EXECUTE'. The row for ID Control is selected, and a dropdown menu is open, showing 'Control' and 'AC-output' sections. The 'Control' section has rows for CT41 (Turn All Converters ON) and CT42 (Turn All Converters OFF). The 'AC-output' section has rows for CT101 (Turn All Converters ON) and CT102 (Turn All Converters OFF).

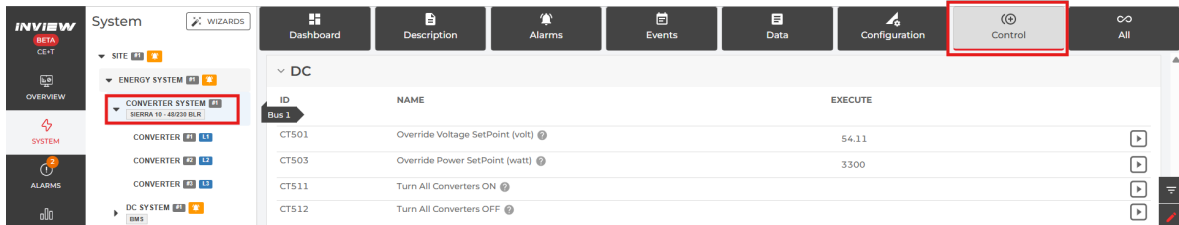

- Module Level

- Both AC and DC: *SYSTEM > SITE > CONVERTER SYSTEM > CONVERTER > Control > Global > CT11 and CT12*
- AC Only: *SYSTEM > SITE > CONVERTER SYSTEM > CONVERTER > Control > AC output > CT21 and CT22*
- DC Only: *SYSTEM > SITE > CONVERTER SYSTEM > CONVERTER > Control > DC > CT31 and CT32*

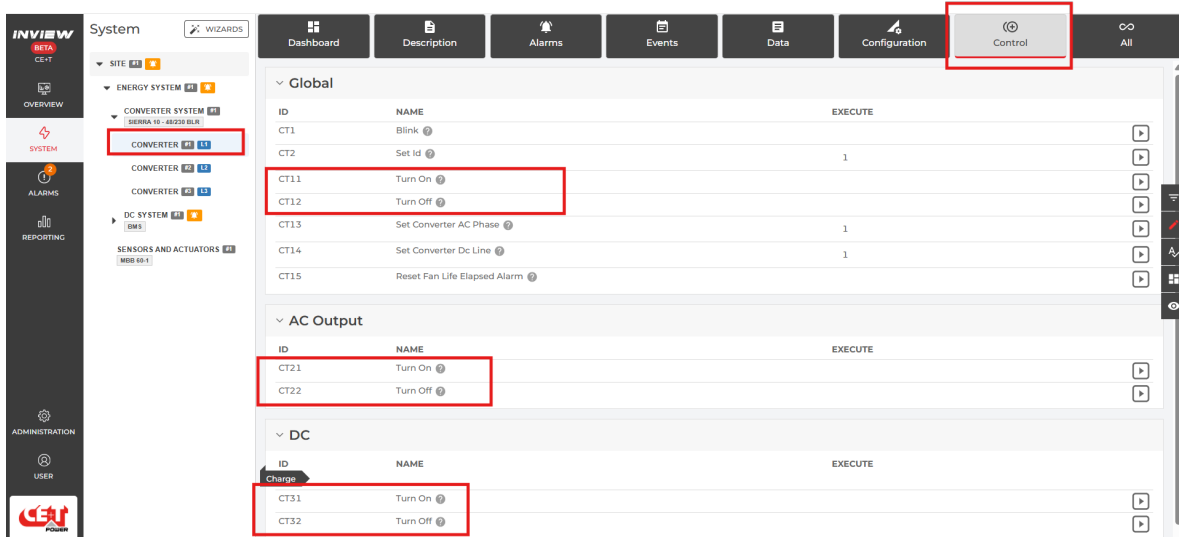

## 7.9 Widgets Configuration

Different types of widgets are available. The configuration appears on the web interface and on the LCD touch screens are not the same.

**Perform the following step for Widgets configuration:**

1. **Configure widgets:** Click the OVERVIEW and click on either EDIT or CONFIGURE WIDGETS button.

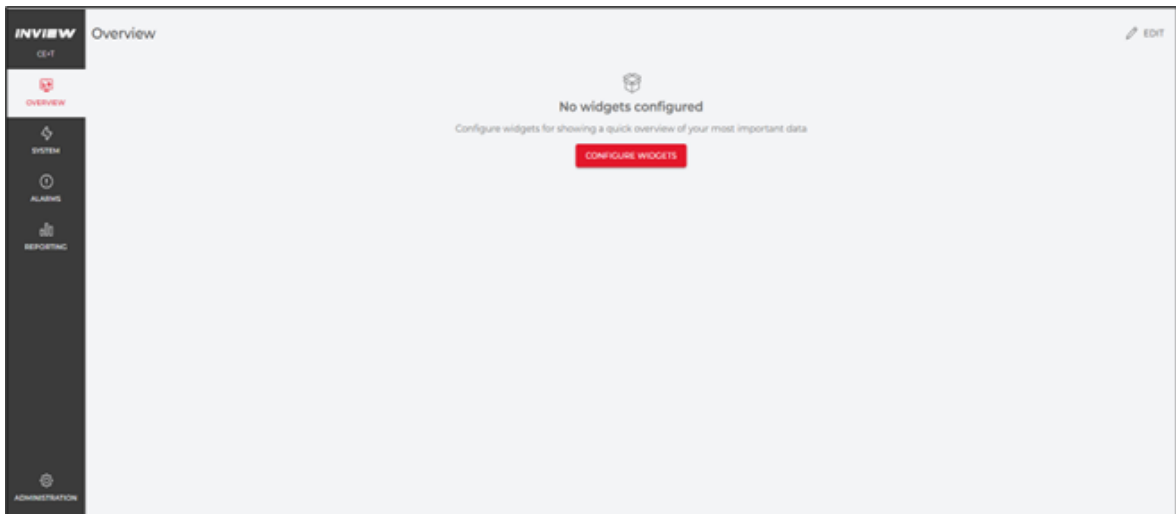

2. Click +ADD WIDGET to add a widget with the relevant parameter and icon.
3. To configure the AC Input widget, click +ADD WIDGET and enter the following details in the Add Widget window:
  - Enter AC Input in the widget name.
  - Click the drop down arrow  and select the specific icon for the widget.
  - Click on the corresponding AC Inputs check-box.
  - Click ADD to save the widget.

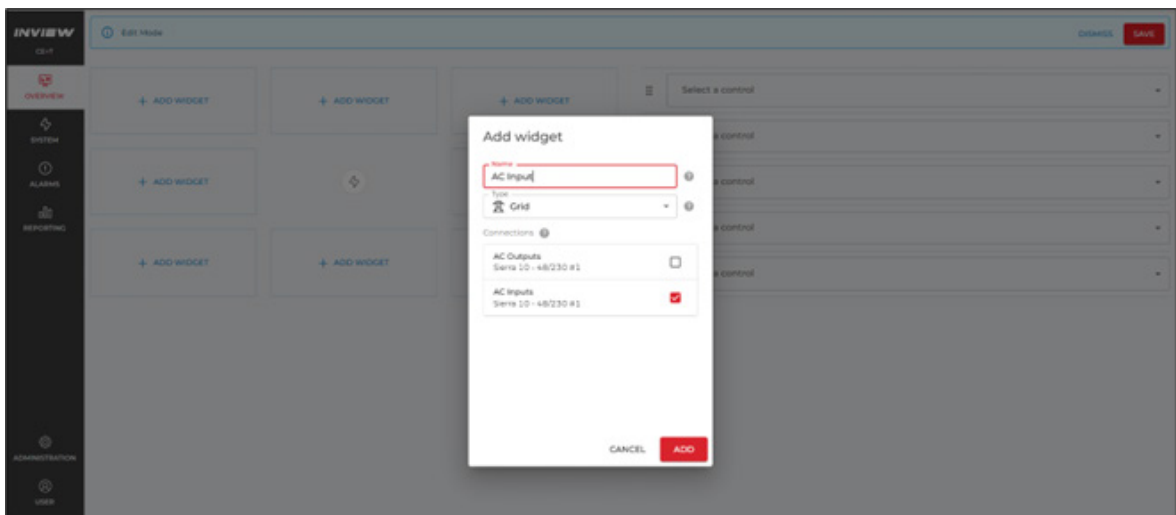

4. To configure the AC Output widget, click +ADD WIDGET and enter the following details in the Add Widget window:
  - Enter AC Output in the widget name on the add widget window.
  - Click the drop down arrow  and select the specific icon for the widget.
  - Click on the corresponding AC Output check-box.
  - Click ADD to save the widget.

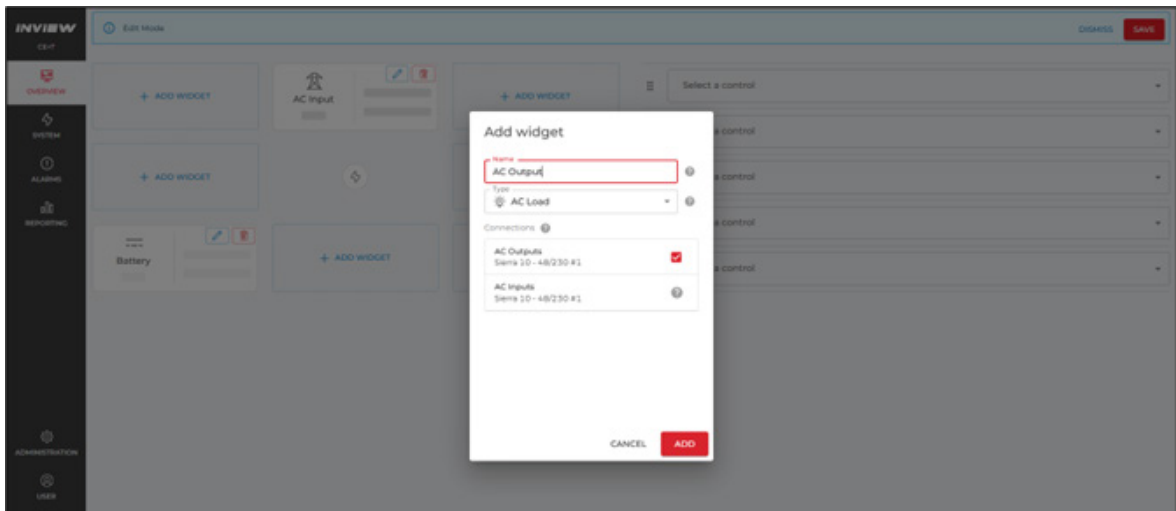

5. To configure the Battery widget, click +ADD WIDGET and enter the following details in the Add Widget window:
  - Enter Battery in the widget name.
  - Click the drop down arrow  and select the specific icon for the widget.
  - Click on the corresponding DC Source check-box.
  - Click ADD to save the widget.

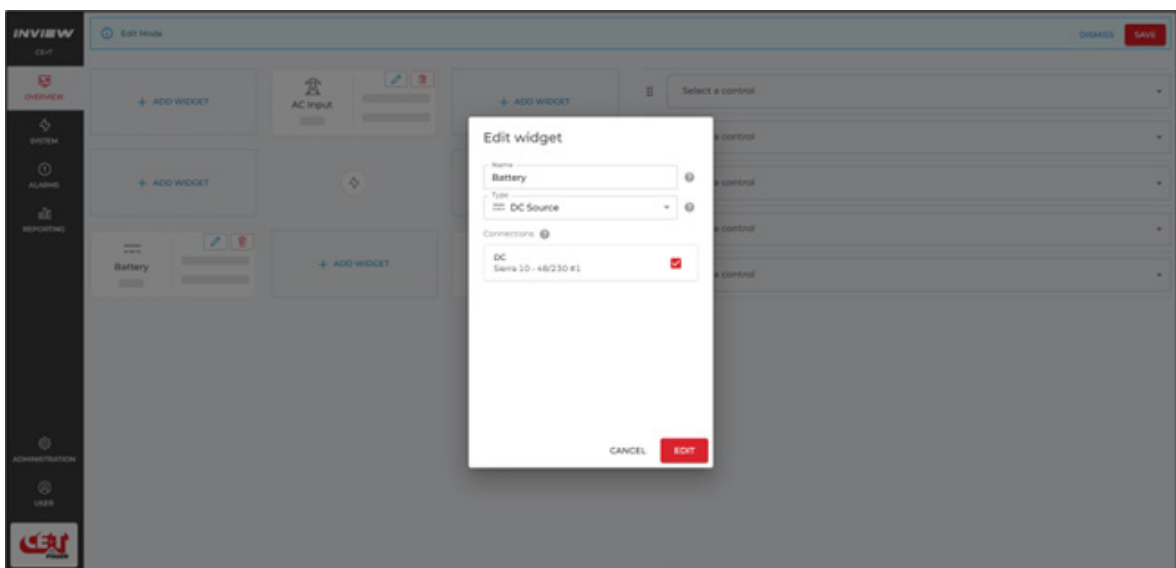

- Follow the step 5 to configure more widgets as per the requirement.
- To configure a control, select any function from the drop-down  list or type function ID for quick access. A maximum of five optional controls can be displayed on the overview screen.

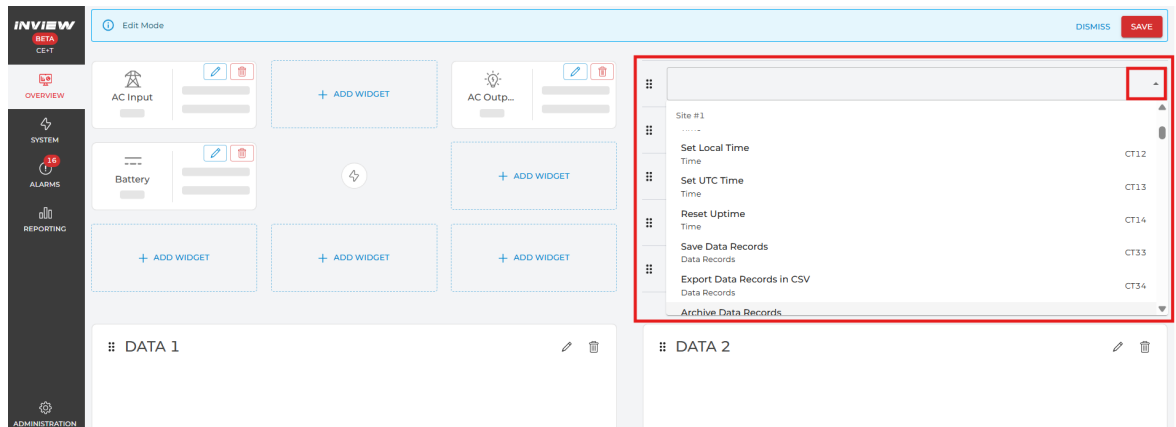

- To configure the Data variable charts, click the + ADD CHART and enter the name for the chart (eg. DATA 1) enter the following details in the Add Chart window:

*Note: Select the type of chart to display on the overview screen. The chart can be graph chart or bar chart based on the requirement. More than one chart can be added to overview screen.*

- Enter DATA 1 in the title tab on the add chart window.
- Click the drop down arrow  on the Data tab.
- Select specific parameter from drop-down list.
- Click ADD to save the chart configuration.

- Click SAVE to save all the configuration and setup.

- The configured widgets, optional tab and charts (bar chart) are now displayed in the Overview.

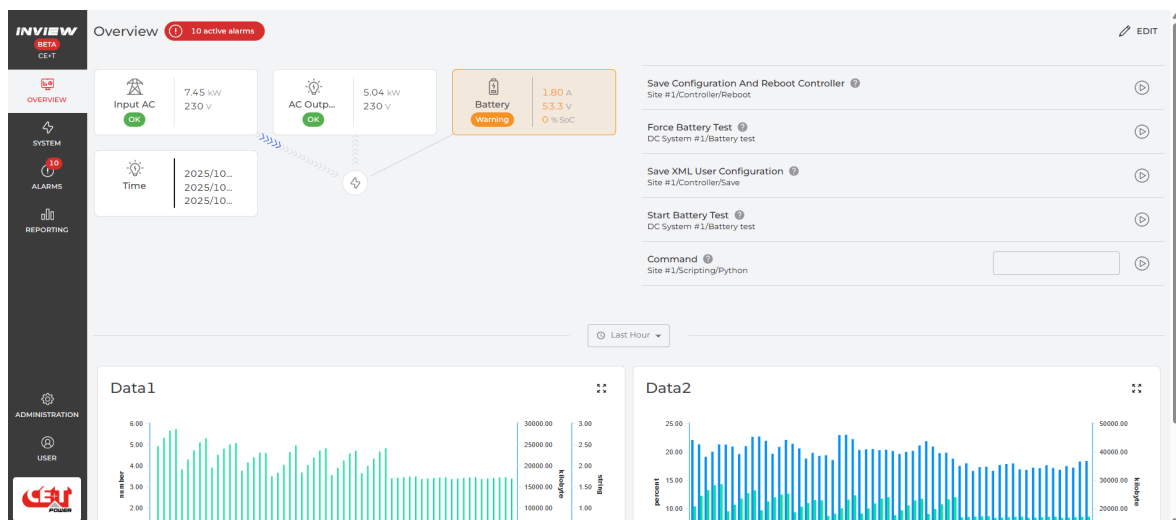

## 7.10 Communication Protocol

### 7.10.1 Modbus

#### 7.10.1.1 Modbus TCP/IP

Modbus over TCP/IP have read and write mode, which means that Modbus can be used for monitor and execute actions on the system.

**Note:** The write mode option is only available with the Operation license.

Port is fixed to standard **Modbus TCP/IP port 502**. This protocol can be either enabled or disabled.

For the Modbus configuration, navigate to **SYSTEM > SITE > Configuration**, scroll down to the *Modbus* section and select the following options. It is also possible to filter on 'Modbus' - Use the filter button on the right.

In the ID **CF155**, select "True" to enable the Modbus TCP/IP function.

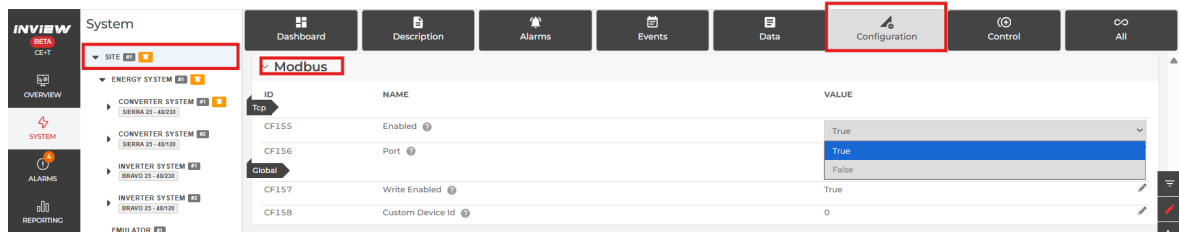

ID **CF157** is a global parameter for both Modbus TCP/IP and Modbus RTU. If the Operation license is installed, CF157 can be used to enable the write mode. The following device/equipment mapping has been defined:

| Device ID | Equipment              |
|-----------|------------------------|
| 1         | DC System 1            |
| 2         | DC System 2            |
| 3         | DC System 3            |
| 4         | DC System 4            |
| 11        | Inverter System 1      |
| 12        | Inverter System 2      |
| 13        | Inverter System 3      |
| 14        | Inverter System 4      |
| 21        | DC/DC Converter (Iris) |
| 31        | Converter System 1     |
| 32        | Converter System 2     |
| 33        | Converter System 3     |
| 34        | Converter System 4     |
| 41        | Solar Power System 1   |
| 42        | Solar Power System 2   |
| 43        | Solar Power System 3   |
| 44        | Solar Power System 4   |
| 91        | Energy System 1        |

| Device ID | Equipment               |
|-----------|-------------------------|
| 100       | Site                    |
| 101       | Sensors And Actuators 1 |
| 102       | Sensors And Actuators 2 |

Users have the option to customize the device IDs according to their preferences.

Example A:

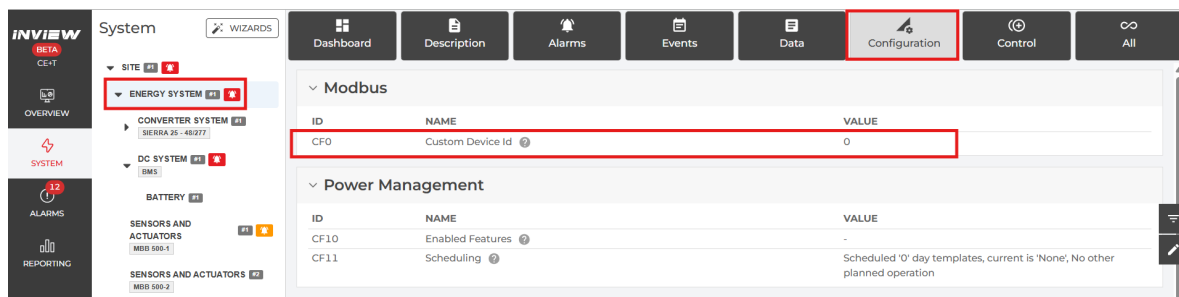

The screenshot shows the 'Configuration' tab in the Inview System interface. The 'Modbus' section is expanded, showing a table with the following data:

| ID  | NAME             | VALUE |
|-----|------------------|-------|
| CF0 | Custom Device Id | 0     |

The 'Power Management' section is also visible, showing settings for CF10 and CF11.

Example B

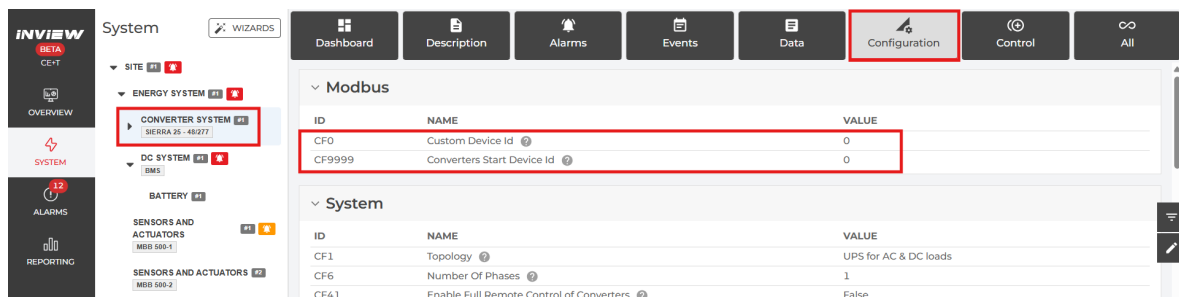

The screenshot shows the 'Configuration' tab in the Inview System interface. The 'Modbus' section is expanded, showing a table with the following data:

| ID     | NAME                       | VALUE |
|--------|----------------------------|-------|
| CF0    | Custom Device Id           | 0     |
| CF9999 | Converters Start Device Id | 0     |

The 'System' section is also visible, showing settings for CF1, CF6, and CF41.

Example C

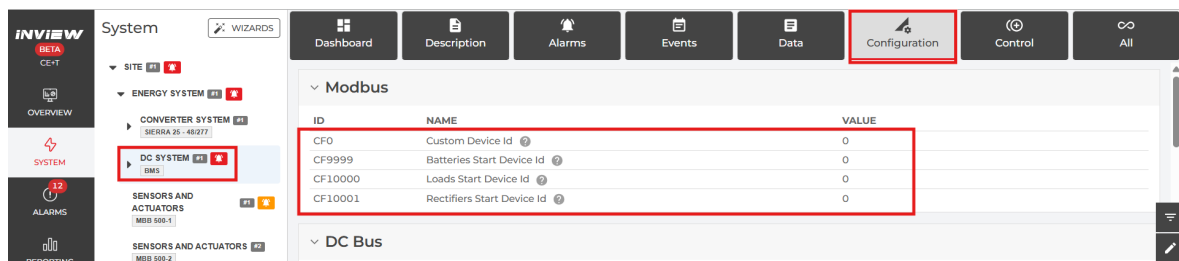

The screenshot shows the 'Configuration' tab in the Inview System interface. The 'Modbus' section is expanded, showing a table with the following data:

| ID      | NAME                       | VALUE |
|---------|----------------------------|-------|
| CF0     | Custom Device Id           | 0     |
| CF9999  | Batteries Start Device Id  | 0     |
| CF10000 | Loads Start Device Id      | 0     |
| CF10001 | Rectifiers Start Device Id | 0     |

The 'DC Bus' section is also visible.

When the equipment does not exist, it will respond with function code 04:

- Each discrete input is associated with the alarm of the equipment, with the same id. Reading 1 means that the alarm is active.
- Each input register corresponds to the data of the equipment. All these values are coded assigned 16 bit. A correction factor is often applied. Some status are coded as uint.
- Each holding register corresponds to the configuration (first 5000 addresses) or control (next 5000 addresses) of the equipment. It only supports entries that can be read and of numeric type. It includes advanced controls

with parameters, complimentary with discrete coils.

- Each **discrete coil** corresponds to the entries for controlling the equipment. It supports only simple control, without any parameters.

The Modbus transport layer is Ethernet over TCP/IP. The default used port is 502:

- Discrete Inputs, alarm reading (Read Only), using modbus command 02.
- Input Registers, data reading (Read Only), using modbus command 04.
- Discrete Coils Table (Command), using modbus command 05.
- Holding registers, using modbus command 03 for multiple read, and 06 for a single write.

If you want to use Modbus to monitor other types of systems, please contact us. We will study the business case and make a proposal.

To download the Modbus data, login to the Inview web interface, navigate to [Administration > Files > MMI References > Generate Modbus Map > Export](#).



The name of the generated file is “ModbusMap.xlsx”. It contains 4 different sheets:

- Alarm discrete *InputData* -> *discrete inputs* related to alarms
- *Data input registers* -> *input registers* related to data
- *Config holding registers 1* -> *holding registers* related to configuration parameters
- *Control holding registers 2* -> *holding registers* related to controls to be executed

Example to read the installed Power DA111 of converter system 1 (ID 31):

- Set the Slave ID to 31
- Use the function 04 (PLC address starts with 30000)
- Check for address 111
- The referred address in the Modbus map is 30111
- The corresponding PLC address is 30112 (1-based)

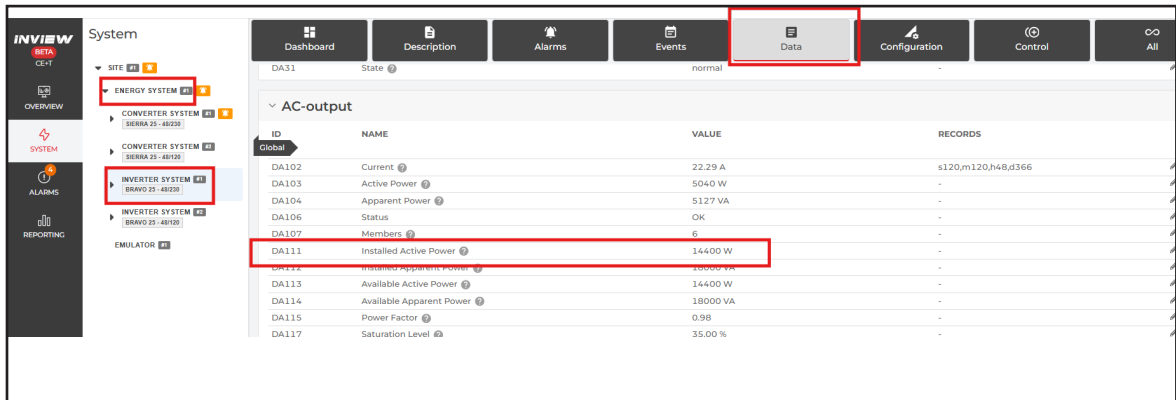

The screenshot shows the Inview software interface. The 'Data' tab is selected in the top navigation bar. The left sidebar shows the 'SYSTEM' menu with 'INVERTER SYSTEM 31' selected. The main content area displays the 'AC-output' section with a table of data points. The 'DA111 Installed Active Power' row is highlighted with a red box.

| ID    | NAME                     | VALUE    | RECORDS            |
|-------|--------------------------|----------|--------------------|
| DA102 | Current                  | 22.29 A  | s120,m120,h48,d366 |
| DA103 | Active Power             | 5040 W   | -                  |
| DA104 | Apparent Power           | 5127 VA  | -                  |
| DA106 | Status                   | OK       | -                  |
| DA107 | Members                  | 6        | -                  |
| DA111 | Installed Active Power   | 14400 W  | -                  |
| DA112 | Installed Apparent Power | 18000 VA | -                  |
| DA113 | Available Active Power   | 14400 W  | -                  |
| DA114 | Available Apparent Power | 18000 VA | -                  |
| DA115 | Power Factor             | 0.98     | -                  |
| DA117 | Saturation Level         | 35.00 %  | -                  |

### 7.10.1.2 Modbus RTU

Modbus RTU have read and write mode. The Modbus RTU is used to monitor and execute actions on the system. Modbus RTU network consists of one master device and one or more slave device.

**Note:** The write mode option is only available with the operation license.

Modbus RTU uses serial communication over a dedicated RS485 line. RS485 is the physical interface for communication. Refer the “5.6.8 CAN / ModBus (RS485) Pin Details”, page 29 for the wires.

To establish communication between the laptop and Converter system through modbus RTU,

Use a RJ45 cable and cut the one end of the RJ45 cable and isolate the Blue (B), Blue white (A) and Brown (GND) wires from the RJ45 cable.

Use a USB cable (USB A-RS232 (FTDI)) and isolate the Yellow (B), Orange (A) and Black (GND).

Connect the USB cables Yellow (B) to Blue wire (B), Orange (A) to Blue white (A) and Black (GND) to Brown (GND) wire of the RJ45 cable.

Modbus RTU connection for Inview Slot and XC:

Connect the cable with RJ45 to the CAN Modbus RTU (RS485) port at the rear of the shelf and connect the other end of the cable with USB to the laptop to retrieve data related to modbus.

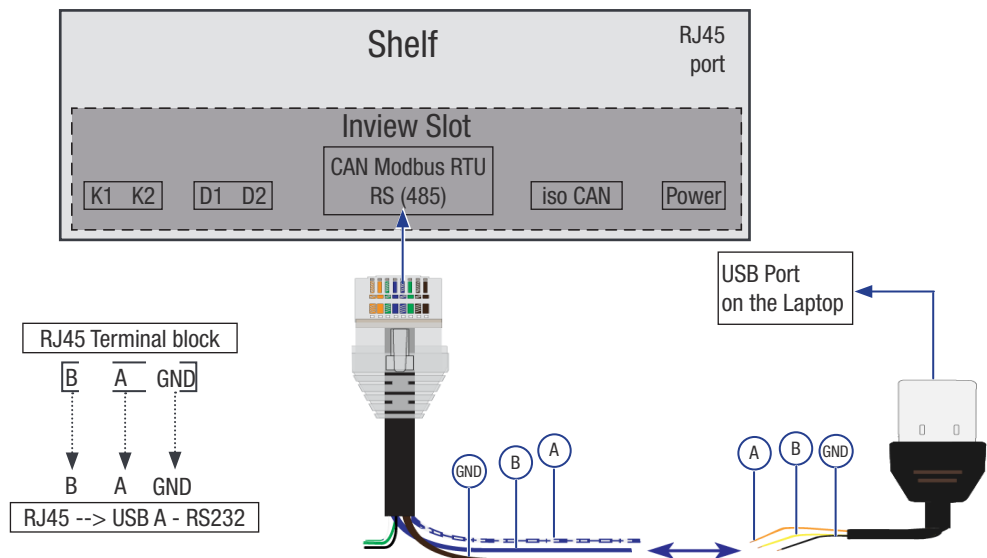

**Modbus RTU connection for Inview S:**

Connect the USB cables Yellow (B) to Blue wire (B), Orange (A) to Blue white (A) and Black (GND) to Brown (GND) wire of the RJ45 cable. Connect the RJ45 cable to the CAN iso RS485 port in the Inview S.

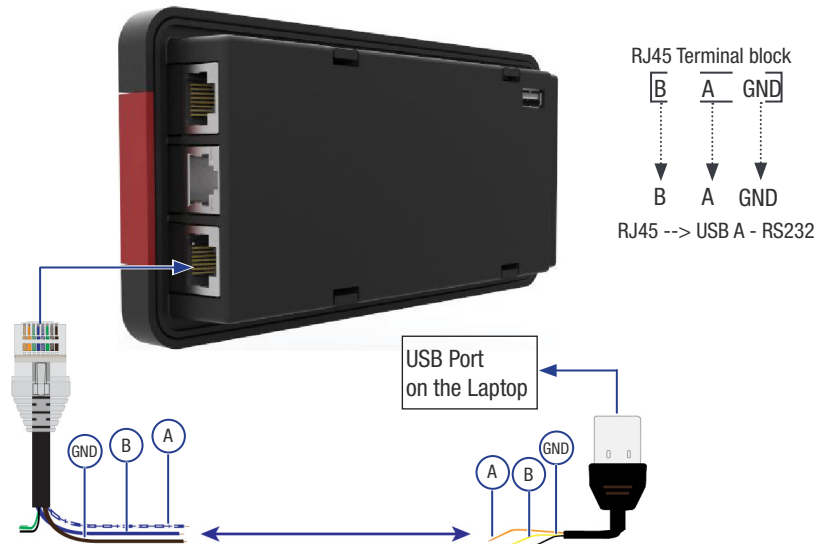

**Modbus RTU connection for Inview X/X+:**

Connect the Yellow (B) to the pin B, Orange (A) to the pin (A) and Black (GND) to the pin GND wire from the USB cable to the RS485 port in the Inview X/X+.

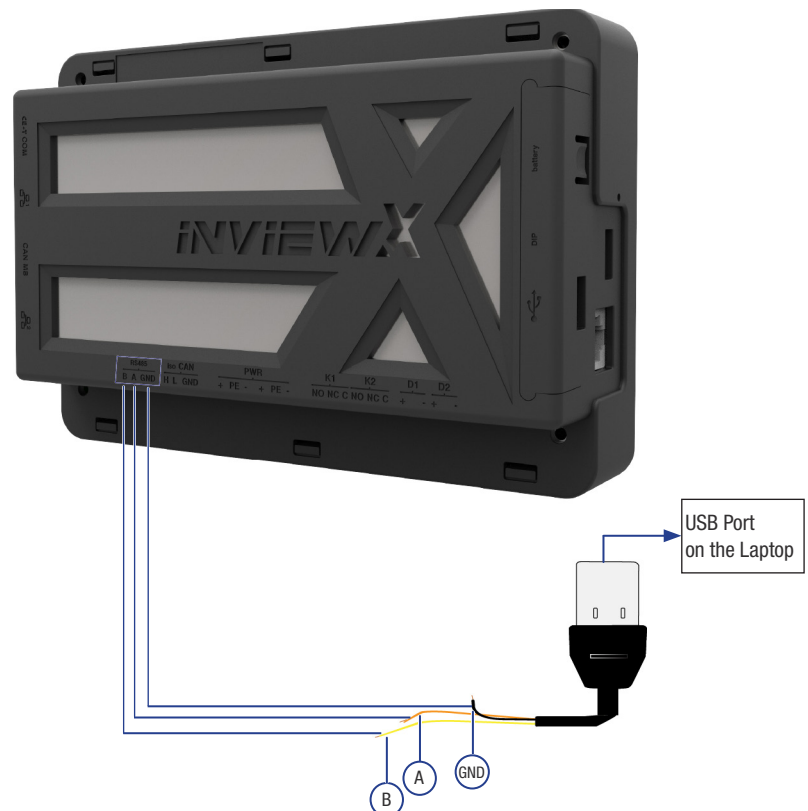

In this setup, Inview acts as a Modbus RTU client. The external Modbus device (polling Inview data) acts as the server. The master device transmits the request message, which includes the server address, function code and data. The server responds with the same function code with the requested data.

**Note:** For monitoring any other system through Modbus, please contact us for further support.

To download the Modbus data, login to the Inview web interface, navigate to [Administration > Files > MMI References > Generate Modbus Map > Export](#).



The name of the generated file is “Modbus.xls”. It contains 4 different sheets:

- *Alarm discrete InputData* -> *discrete inputs* related to alarms
- *Data input registers* -> *input registers* related to data
- *Config holding registers 1* -> *holding registers* related to configuration parameters
- *Control holding registers 2* -> *holding registers* related to controls to be executed

To read the Modbus RTU (Through Modbus setup application). Open the Modbus application to setup the following parameters.

- Set the Slave ID to *31*
- *Function as 04* Read Input Register
- Set address *111* (*PLC Address = 30111*)
- The referred address in the Modbus map is *30111*
- The corresponding *PLC address* is *30112* (*1-based*)

To configure the **Modbus RTU** in Inview, navigate to *SITE > Configuration*, scroll down to **RS485 Bus**.

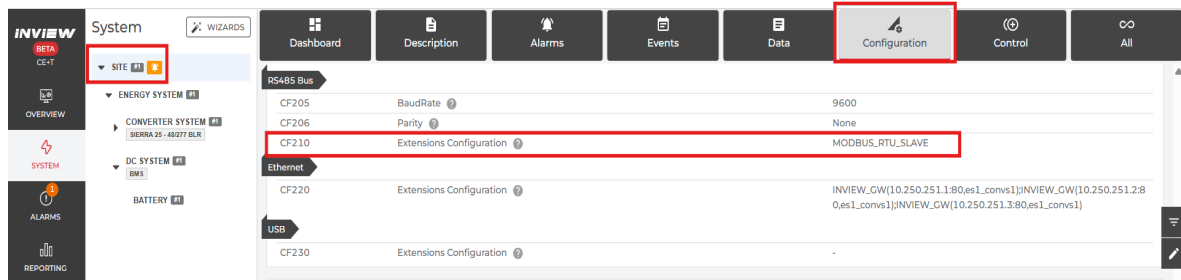

- *CF205 - Baud Rate to 9600*
- *CF206 - Parity- Even*
- *To set CF210 extensions configuration - Edit > Wizard > Add Serial Equipment > Custom Equipment, type MODBUS\_RTU\_SLAVE and SAVE.*
- *CF210 - Extensions configuration to MODBUS\_RTU\_SLAVE*

To establish communication both Master and Slave devices should have the same Baud rate and Parity.

### 7.10.2 SNMP

This section describes the Management Information Base (MIB) schema design for SNMP V1, V2c and V3 configuration. A MIB schema describes the structure of information served by a Simple Network Management Protocol Subsystem (SNMP) agent.

For the SNMP configuration, navigate to *SYSTEM > SITE > Configuration*, scroll down to the *SNMP Agent* section and select the following options.

- In the ID **CF61**, select “True” to enable the SNMP function and enter the port address in the ID **CF62**.
- In the ID **CF63**, select the SNMP version **V1, V2c or V3**.

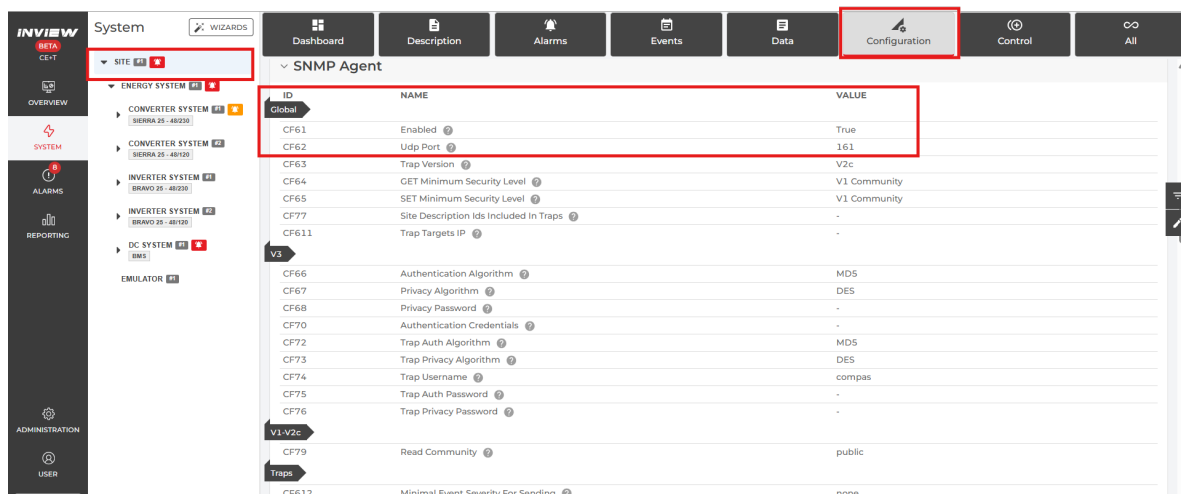

### 7.10.3 MIB

The MIB file describes the specific format of data provided by the SNMP agent running within the subsystem. The data is grouped in terms of high-level objects and therefore models a top-down hierarchical design.

To download the SNMP MIB file, go to *Administration > Files > MMI References* and click *SNMP MIB* “Export” button.

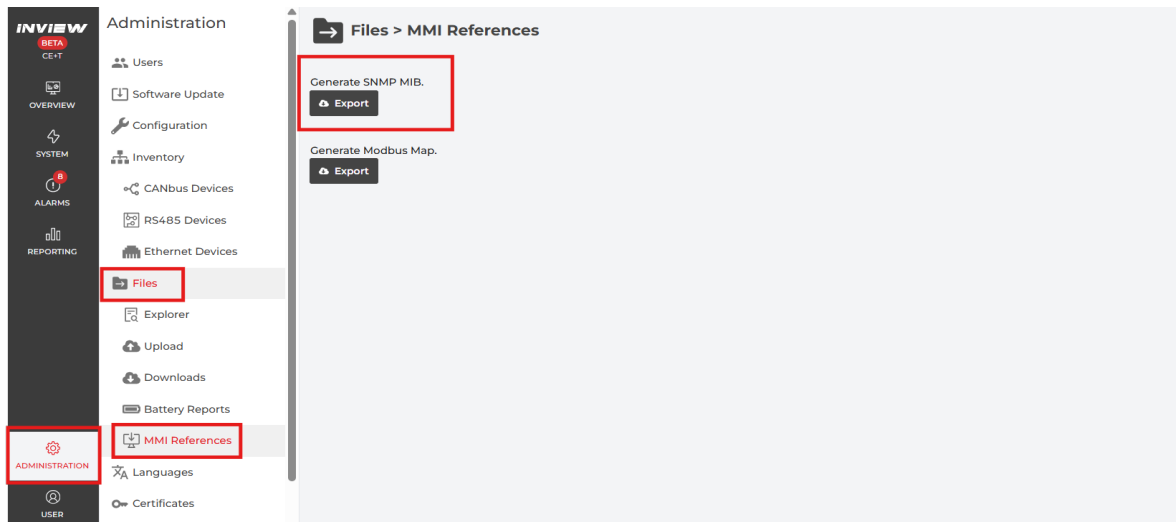

## 7.11 Cyber Security

### 7.11.1 Password Policy

Starting from Inview software version 5.5, a new password policy is introduced. The password must be a minimum of eight characters.

If the wrong password is entered continuously five times, next time, the Inview restrict to login, and it will allow again only after five minutes.

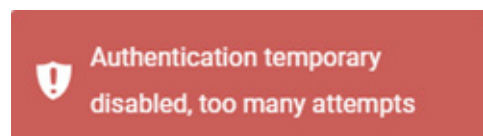

### 7.11.2 Weak Password Alarm

An alarm is raised when the system detects any user using a legacy password storage, default password or default pin code.

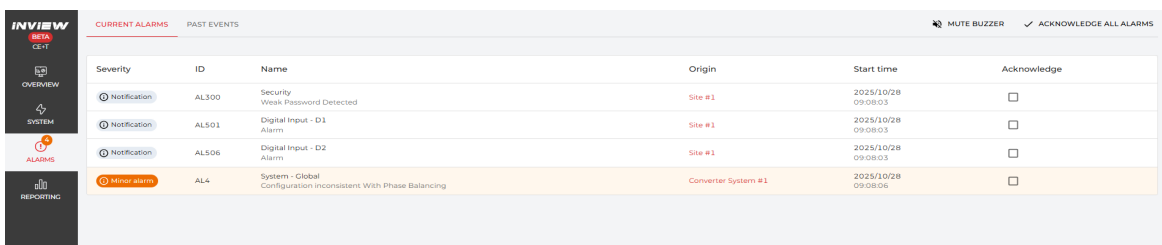

| Severity     | ID    | Name                                                            | Origin              | Start time          | Acknowledge              |
|--------------|-------|-----------------------------------------------------------------|---------------------|---------------------|--------------------------|
| Notification | AL300 | Security Weak Password Detected                                 | Site #1             | 2025/10/28 09:08:03 | <input type="checkbox"/> |
| Notification | AL501 | Digital Input - D1 Alarm                                        | Site #1             | 2025/10/28 09:08:03 | <input type="checkbox"/> |
| Notification | AL506 | Digital Input - D2 Alarm                                        | Site #1             | 2025/10/28 09:08:03 | <input type="checkbox"/> |
| Minor alarm  | AL4   | System - Global Configuration inconsistent With Phase Balancing | Converter System #1 | 2025/10/28 09:08:06 | <input type="checkbox"/> |

To fix the weak password alarm, check the followings:

- Make sure the PIN code is not having the default value.
- Make sure that no user is using the default password.
- If the configuration is migrated from an older version, use the web interface and change the existing password.

### 7.11.3 Password Protection

Starting from Inview software version 5.5, a new password protection feature is added. To know more about it and configure it, navigate to *SYSTEM > SITE > Configuration > Webserver section > CF33 (Enable password recovery)*.

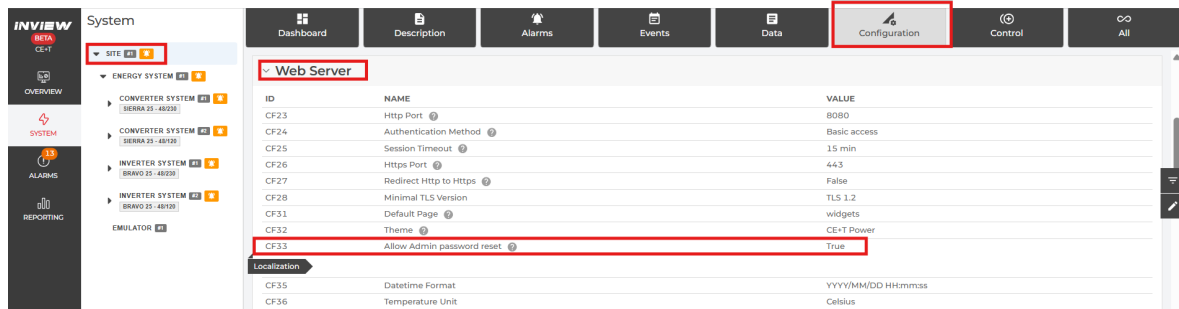

- If “True” is selected, the web interface passwords and PIN details will be present while exporting the configuration and log files. *(Note: the password details are encrypted)*
- If “False” is selected, the password (for users, SNMP, Mail, MQTT, etc.) and PIN details are protected and will not be available in the configuration and log files.

### 7.11.4 Software Downgrade and Reset

To know about software downgrade and factory reset, navigate to *SYSTEM > SITE > Configuration*, scroll down to *Controller* section to maintenance *ID CF152 and CF153*. By default, the “True” option will be present on both parameters.

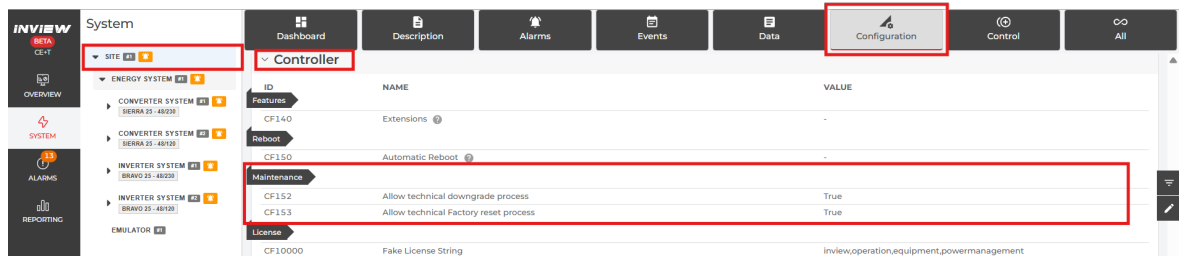

**Warning:** If both CF152 and 153 parameters are in False condition and the controller is corrupted, there is no possibility of recovering the data and cannot do the factory reset.

- **CF152 (Allow technical downgrade process):** Select the “True” option and downgrade the software version to the previous one using the USB key. Contact CE+T for the downgrading process.
- **CF153 (Allow technical Factory reset process):** Select the “True” option and perform the factory reset using USB Key. After the factory reset, the controller will be in default settings. Contact CE+T for the factory reset process.

## 8. Overview - LCD Interface

### 8.1 Inview Slot - LCD Display

Once the system is powered up, the Inview Slot is up and ready for operation. The LCD is a 1.8-inch touch screen and user can only view the system details through the interface.

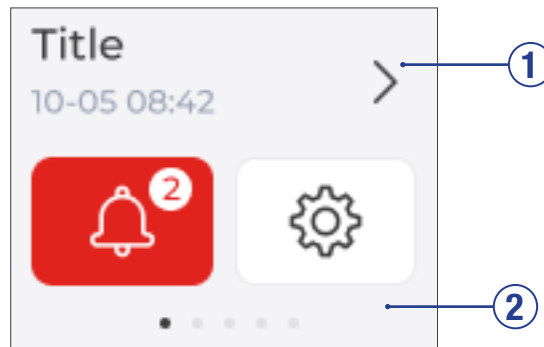

- **Interface area (1):** The interface area provides information about the corresponding page.
  - Displays the Site place, Date and Time.
  - The notification icon to view Active Alarm and Past Events and the settings icon provides access to other action screens.
  - Navigation arrows to the next screen or swipe left and right. Up and down arrows appear on some screens, indicating more information is present.
- **Status bar- Widgets (2):**

The status bar appears throughout the interface and indicates the screen sequence.

#### 8.1.1 LED Indications

Three LED's are present behind the front black plastic of the controller to indicate major alarm, minor alarm, and system status. These LED's are not visible until they illuminate during the corresponding action occurs.

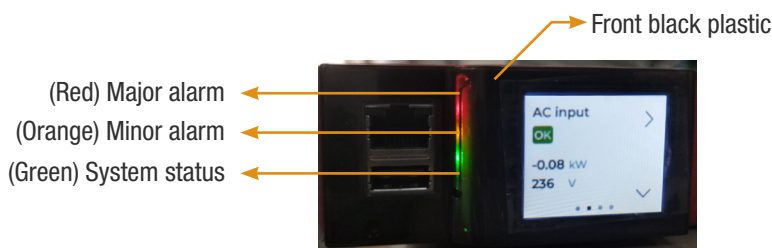

### 8.1.2 Menu Structure

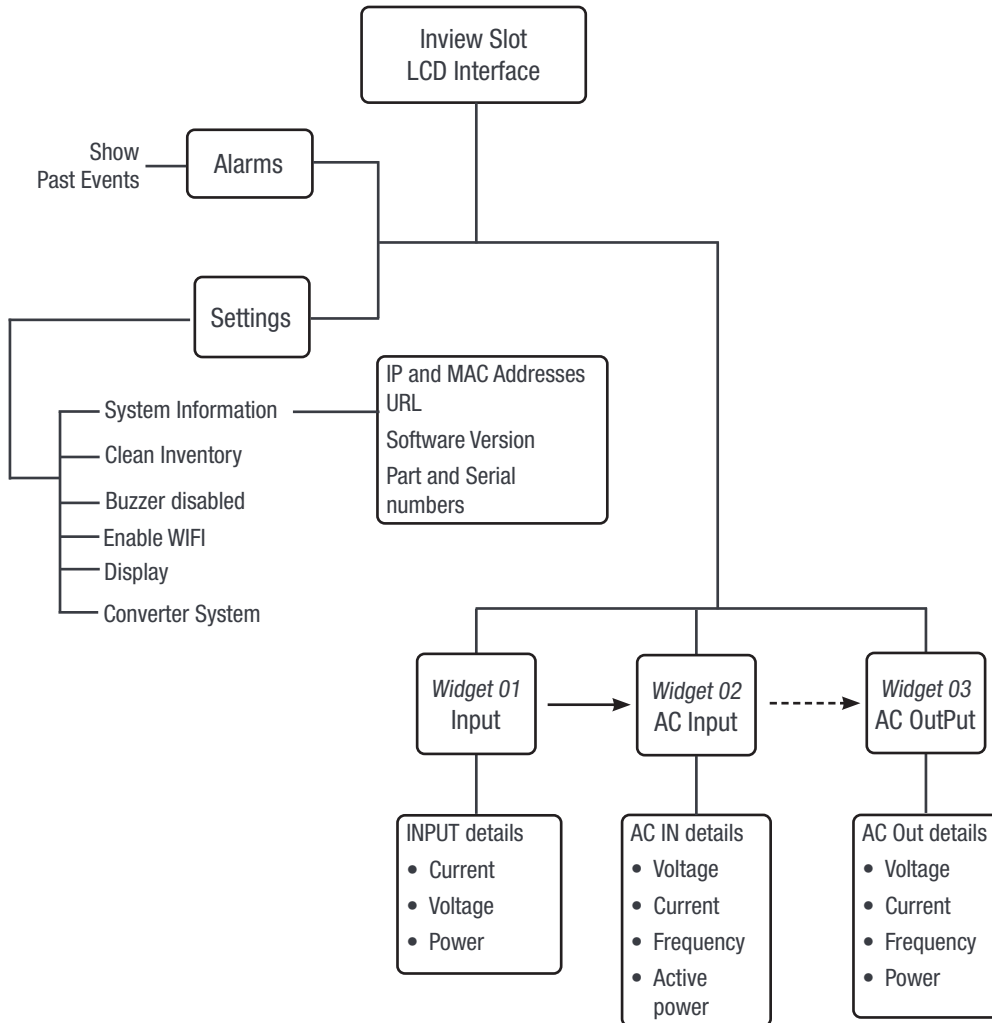

The home page is the default page in the LCD interface, and other pages are arranged in the below sequence.

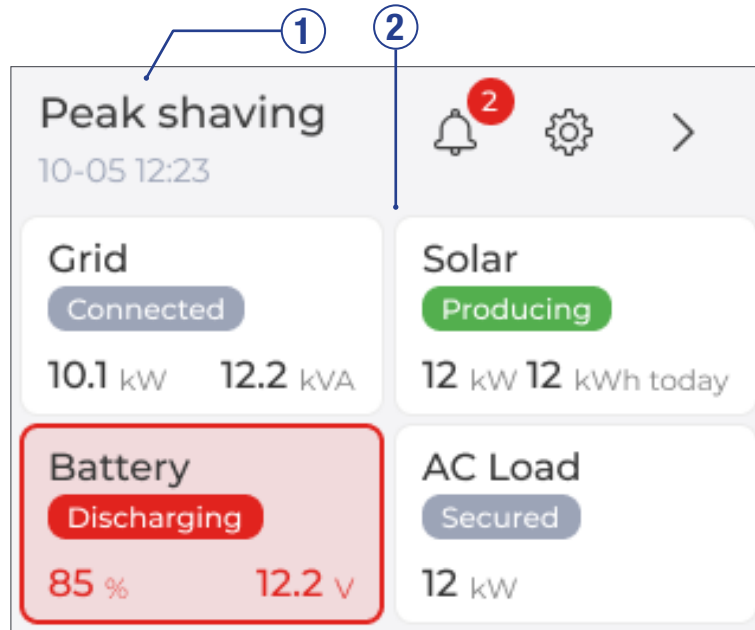

## 8.2 Inview S - LCD Interface

Inview S LCD interface is a 2.8-inch touch screen. It does not have any user account, the user can only view the system details. The LCD interface is protected with the PIN during any action request. To modify the PIN, refer section 7.2.2, page 39. Once system is powered upon, the Inview S is up and ready for operation.



- **Header (1):** Displays the Site name, Date and Time.
  - **Notification:** Tapping on  goes to Active Alarm and Past Events screen.
  - **Administration:** Tapping on  provide access to different action screens.
- **Interface Area (2):** Tapping on the widget provides the corresponding parameter information. Provides information about the corresponding screen. In some screens, left and right navigation buttons appear, indicating more screens are present.
- **Navigation arrows** for the next and previous pages. Up and down arrows appear on some screens, indicating more information is present.

### 8.2.1 LED Indications

Three LED's are present at front side of the controller to indicate major alarm, minor alarm, and system status.

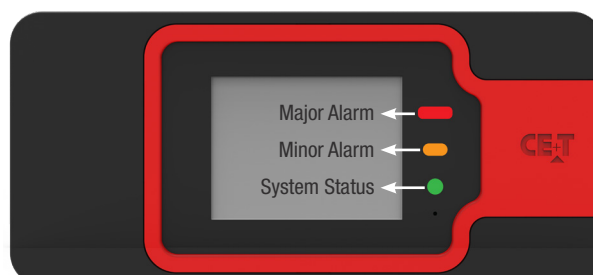

### 8.2.2 Menu Structure

The below tree provides an overview of the menu structure in the Inview S LCD interface.

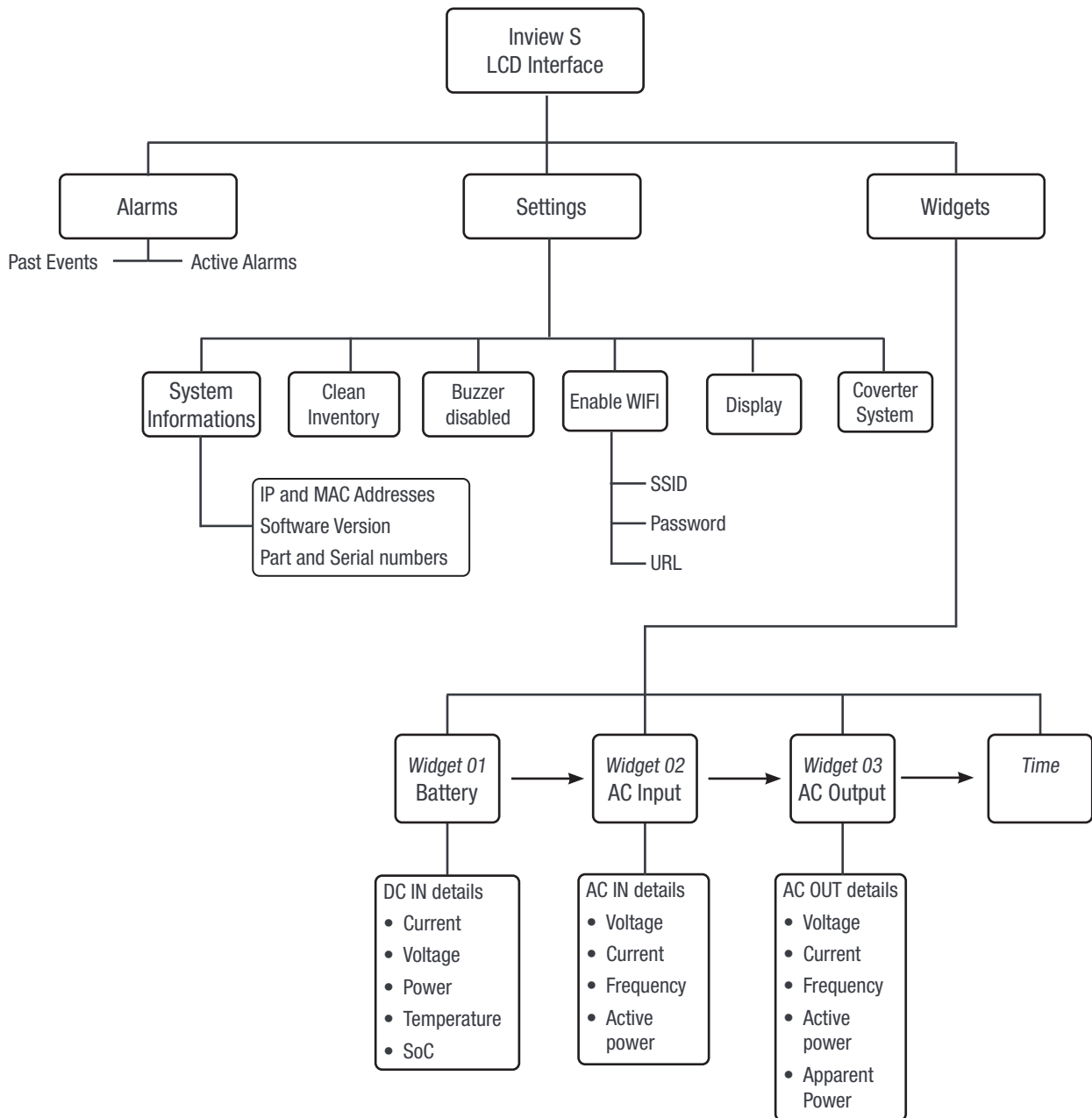



### 8.3 Inview X / X+ - LCD Interface

Inview X / X+ LCD interface is a 7-inch touch screen. Through the LCD interface, the user can view and access the system details. Once the system is powered upon, the Inview X / X+ is up and ready for operation.

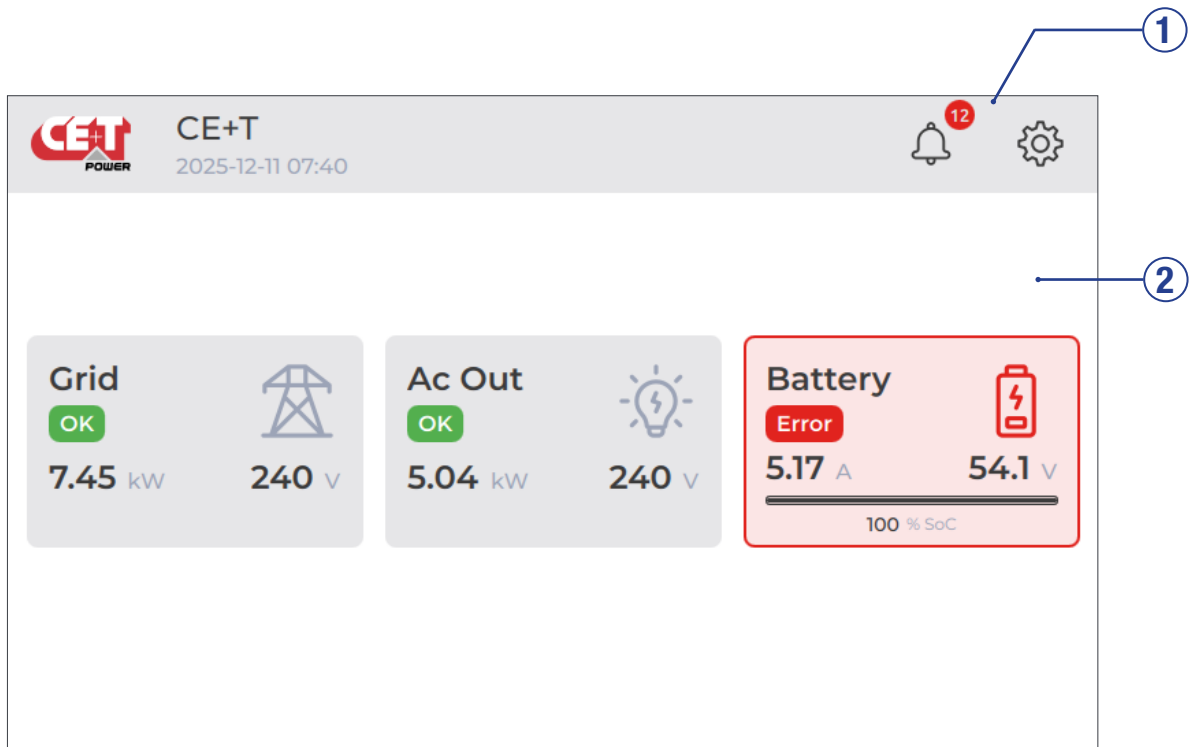
**Note:** Interface graphics and layout may change based on firmware version.



- **Header (1):** Displays the Site name, Date and Time.
  - **Notification:** Tapping on  goes to Active Alarms and Past Events screen.
  - **Administration:** Tapping on  provide access to different action screens.
- **Interface Area (2):** Tapping on the widget provides the corresponding parameter information. Provides information about the corresponding screen. In some screens, left and right navigation buttons appear, indicating more screens are present.
- **Navigation arrows** for the next and previous pages. Up and down arrows appear on some screens, indicating more information is present.

### 8.3.1 Menu Structure

The below tree provides an overview of the menu structure in the Inview X / X+ LCD interface.

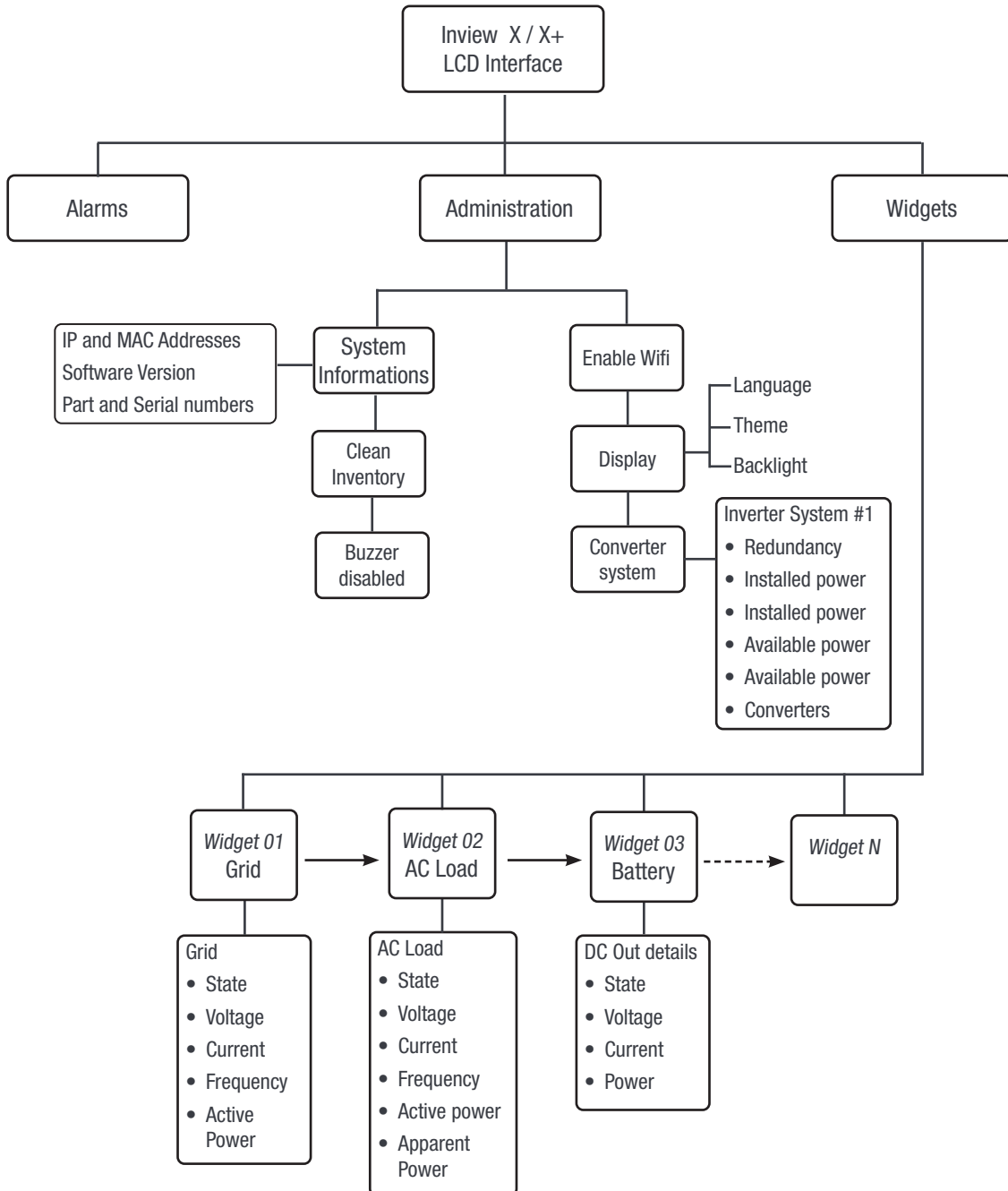

### 8.3.2 LED Indications

Three LED's are present behind the front white plastic of the controller to indicate major alarm, minor alarm, and system status. These LED's are not visible until they illuminate during the corresponding action occurs.

Light Blue: Normal Operation

Orange: Minor Alarm

Red: Major Alarm



### 8.4 Inview XC - LED Indications

Three LED's are present at top side of the controller to indicate major alarm, minor alarm, and system status.



Red: Major Alarm

Orange: Minor Alarm

Green: System status (Normal Operation)

### 8.5 LCD Interface - Terminology

The below table provides the description of terminology which appears in Inview Slot, S, X and X+ LCD interface.

| S.NO | Terminology        | Description                                                                                                                                                                                                                                                                                      |
|------|--------------------|--------------------------------------------------------------------------------------------------------------------------------------------------------------------------------------------------------------------------------------------------------------------------------------------------|
| 1    | Clean Inventory    | The controller performs a complete scan and remove the non-active converters from the converter list.<br><br><i>Note: If any parameter is changed, an authentication page appears. Enter the display PIN password to apply changes. To modify the password, refer to section 7.2.2, page 39.</i> |
| 2    | Mute buzzer        | Buzzer sound will be muted                                                                                                                                                                                                                                                                       |
| 3    | Logs               | Display the latest 100 events occurred                                                                                                                                                                                                                                                           |
| 4    | System Information | Displays product, network and software details                                                                                                                                                                                                                                                   |

## 9. Defective Unit

### 9.1 Return Defective Inview

- A repair request should follow the regular logistics chain:  
End-user => Distributor => CE+T Power.
- Before returning a defective product, a RMA number must be requested through the <http://my.cet-power.com> extranet. Repair registering guidelines may be requested by email at [repair@cet.be](mailto:repair@cet.be)
- **Freight costs:**
  - The cost to ship the unit(s) from the Customer's premises back to CE+T Power is at the Customer's charge.
  - CE+T Power will pay for the shipping of the unit(s) back to the Customer's premises.
- **Warranty:**
  - The warranty will be void if the transport conditions or packing were inadequate.
  - The warranty will be cancelled if the unit sent for repair has been opened by parties other than a CE+T approved Repair Centre.
- **Repair costs:**
  - If the faulty unit is under warranty, CE+T Power will bear the repair costs.
  - If the warranty is void, the repair costs will be invoiced to the Customer.
  - If a unit sent back to CE+T Power (Repair or Swap) presents no defect or failure, a lump sum amount will be charged to the Customer.
- **Swap conditions:**
  - You must provide CE+T Power with a Purchase Order for the new unit that you are requesting, at the current price. No Swap request will be accepted without it!
  - Within 3 months of the reception of our Swap approval email, you will have to provide CE+T Power with a tracking reference proving that you have shipped the faulty unit(s) back to CE+T Power.
  - If CE+T Power does not receive the tracking reference or the unit in time, CE+T Power will automatically invoice the unit(s) sent in exchange, at the current price list value.
- **RMA:**
  - Your Return Material Authorization number (RMA) and the address of the appropriate Repair Centre will be confirmed to you after careful review of your request.
  - The RMA number must be present on the packing and all the paperwork of the returned material.
  - So please, wait until you receive these two information before you ship us the faulty unit.

# 10. Troubleshooting and Service

## For Service

- Check the Service Level Agreement (SLA) of your vendor. Most of the time they provide assistance on call with integrated service. If such SLA is in place, you must call their assistance first.
- To raise the request support ticket to CE+T customer support, perform the following steps:
  - Navigate to ADMINISTRATION > Support and click “Download support package” to download the “diagnostics” zip file.

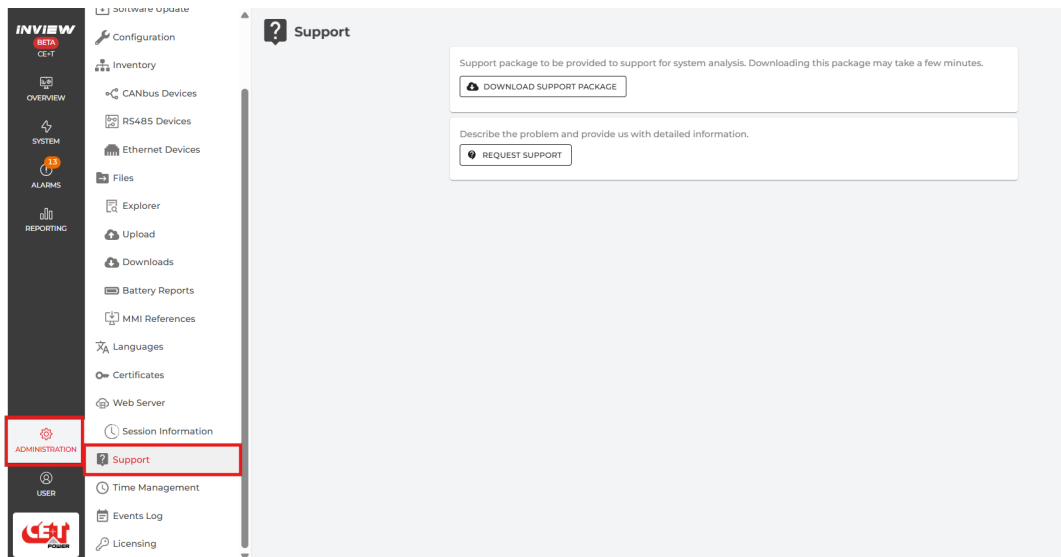

- For USA and Canada:
  - Attach the downloaded the “diagnostics” zip file in the email
  - Send it to to CE+T America customer support: [tech.support@cetamerica.com](mailto:tech.support@cetamerica.com)
- For Rest of the world:
  - Click “[Request support](#)” to send the diagnostic file to CE+T customer support.
  - You will be redirected to our ticketing platform.
  - Sign in to CE+T Power - Support center
  - Open a new ticket and attach the diagnostic file
  - Click Submit to send the request support ticket to CE+T customer support

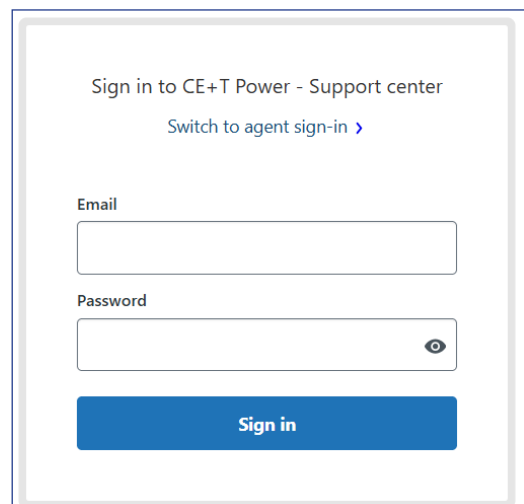

The screenshot shows a sign-in form for the CE+T Power - Support center. It includes a title, a link to switch to agent sign-in, input fields for Email and Password, and a blue Sign in button.

# 11. Annexe 1: Converter - Parameter List

To view and edit the converter parameters, navigate to *SYSTEM > SITE > Energy System > Converter System > Configuration*.

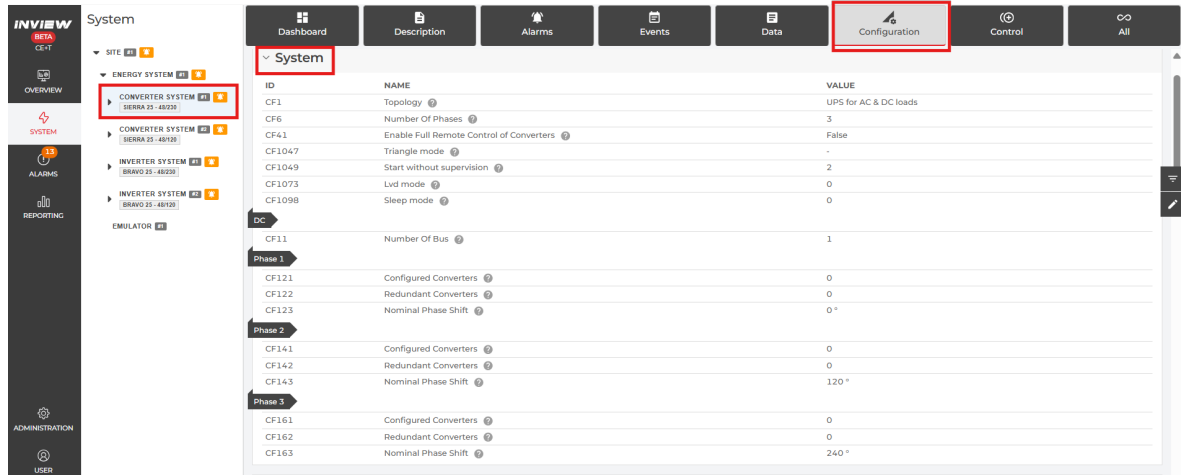

The screenshot shows the Inview system configuration interface. The left sidebar contains navigation options: OVERVIEW, SYSTEM, ALARMS, REPORTING, ADMINISTRATION, and USER. The main content area is titled 'System' and includes a breadcrumb trail: SYSTEM > SITE > ENERGY SYSTEM > CONVERTER SYSTEM > CONFIGURATION. A table of parameters is displayed, categorized by DC, Phase 1, Phase 2, and Phase 3.

| ID             | NAME                                     | VALUE                 |
|----------------|------------------------------------------|-----------------------|
| CF1            | Topology                                 | UPS for AC & DC loads |
| CF6            | Number Of Phases                         | 3                     |
| CF41           | Enable Full Remote Control of Converters | False                 |
| CF1047         | Triangle mode                            | -                     |
| CF1049         | Start without supervision                | 2                     |
| CF1073         | Lvd mode                                 | 0                     |
| CF1098         | Sleep mode                               | 0                     |
| <b>DC</b>      |                                          |                       |
| CF11           | Number Of Bus                            | 1                     |
| <b>Phase 1</b> |                                          |                       |
| CF121          | Configured Converters                    | 0                     |
| CF122          | Redundant Converters                     | 0                     |
| CF123          | Nominal Phase Shift                      | 0°                    |
| <b>Phase 2</b> |                                          |                       |
| CF141          | Configured Converters                    | 0                     |
| CF142          | Redundant Converters                     | 0                     |
| CF143          | Nominal Phase Shift                      | 120°                  |
| <b>Phase 3</b> |                                          |                       |
| CF161          | Configured Converters                    | 0                     |
| CF162          | Redundant Converters                     | 0                     |
| CF163          | Nominal Phase Shift                      | 240°                  |

If you want to have an overview of standard systems' parameters, you can also view the parameters in our Monitoring Emulator <https://www.cet-power.com/en/monitoring-emulator/>. Do not hesitate to use the help buttons for more information about the parameters.

## 12. Annexe 2: PLC/Boolean Expression

### 12.1 Overview

PLC stands for Programmable Logic Controller. It allows adding custom features (data or alarms) by using some logical expression. It is very cost-effective for regulation where the main loop is not faster than one second.

Some configuration elements can be filled with a Boolean expression or a mathematical expression. In the following sections, you will find information about the syntax and some examples of valid expressions. PLC is only available with 'Operation' license.

A PLC Data is defined by any mathematical operation over any data.

A PLC Alarm is defined by any combination/operation of any information available in Inview. By default, a PLC alarm will have a severity level equal to 'none' so that it does not affect the system when it is incorrectly configured. For the alarm to pop up, it is needed to change the configuration of the alarm under 'Alarms'.

Boolean expressions can be used to open/close relays under user defined logics for their requirements and for specific alarm monitoring.

### 12.2 Abbreviations used in the Syntax

| Abbreviations  | Descriptions                                                                                              |
|----------------|-----------------------------------------------------------------------------------------------------------|
| esX            | Refers to the Energy System with ID X                                                                     |
| invsX          | Refers to the Inverter System with ID X                                                                   |
| convsX         | Refers to the Converter System with ID X                                                                  |
| dcdcX          | Refers to the DC Converter System with ID X                                                               |
| rdcsx          | Refers to the Remote DC System with ID X                                                                  |
| dcX            | Refers to the DC System with ID X                                                                         |
| saX            | Refers to the Sensors and Actuators with ID X                                                             |
| emX            | Refers to the Energy Meter with ID X                                                                      |
| spsX           | Refers to the Solar Power System with ID X                                                                |
| invX           | Refers to the Inverter with ID X                                                                          |
| coX            | Refers to the Converter with ID X                                                                         |
| batX           | Refers to the Battery with ID X                                                                           |
| loadX          | Refers to the (DC) Load with ID X                                                                         |
| daX            | Refers to Data with ID X                                                                                  |
| alX            | Refers to Alarm with ID X                                                                                 |
| cfX            | Refers to Configuration parameter with ID X                                                               |
| ctX            | Refers to Control with ID X                                                                               |
| deX            | Refers to Description with ID X                                                                           |
| severity_level | Refers to the highest severity level of the relative equipment (0->9)                                     |
| severity_type  | Refers to the highest severity type of the relative equipment (none - warning - minor - major - critical) |

### 12.3 Use of Syntax to Access Data Entries from a Monitored Device

| Syntax              | Explanation                                                                                                                                                                                                                         |
|---------------------|-------------------------------------------------------------------------------------------------------------------------------------------------------------------------------------------------------------------------------------|
| @(daXXX)            | The data with ID XXX of the relative equipment (of the equipment where the PLC is written). Example: @(data501), @(da501)                                                                                                           |
| @(esY_daXXX)        | The data with ID XXX relative to the Energy System with ID Y.<br>Example: @(es1_da100) – Denotes the active scheduling with ID DA100 from Energy System #1 (only available with some power management features)                     |
| @(spsY_daXXX)       | The data with ID XXX relative to the Solar Power System with ID Y.<br>Example: @(sps1_da11) – Denotes the data with ID DA11 from Solar Power System #1 (only available when the solar converter communicates correctly with Inview) |
| @(dcY_batZ_daXXX)   | The data with ID XXX relative to the Battery with ID Z of the DC System with ID Y.<br>Example: @(dc1_bat1_da5) – Denotes the voltage measurement data with ID DA5 from Battery #1 of DC System #1                                   |
| @(dcdcY_coZ_daXXX)  | The data with ID XXX relative to the Converter with ID Z of the DC Converter System with ID Y.<br>Example: @(dcdc1_co1_da5) – Denotes the data with ID DA5 from Converter #1 of DC Converter System #1                              |
| @(convsY_coZ_daXXX) | The data with ID XXX relative to the Converter with ID Z of the Converter System with ID Y. Example: @(convs1_co1_da8) – Denotes the temperature measurement data with id DA8 from Converter #1 of Converter System #1              |
| @(invsY_invZ_daXXX) | The data with ID XXX relative to the Inverter with ID Z of the Inverter System with ID Y.<br>Example: @(invs1_inv1_da8) – Denotes the temperature measurement data with ID DA8 from Inverter #1 of Inverter System #1               |
| @(emY_daXXX)        | The data with ID XXX relative to the Energy Meter with ID Y.<br>Example: @(em1_da10) – Denotes the current measurement data with ID DA10 from Energy Meter #1                                                                       |

Other possible syntaxes:

- @(dcY\_daXXX), @(dcY\_alXXX),...
- @(saY\_daXXX), @(saY\_alXXX),...
- @(invsY\_daXXX), @(invsY\_alXXX),...
- @(convsY\_daXXX), @(convsY\_alXXX),...
- @(spsY\_daXXX), @(spsY\_alXXX),...
- @(dcdcY\_daXXX), @(dcdcY\_alXXX),...

### 12.4 Use of Syntax to Access Alarms Grouped by Severity Level or Severity Type

|                       |                                                                                                                                                                             |
|-----------------------|-----------------------------------------------------------------------------------------------------------------------------------------------------------------------------|
| @(severity_level)     | The highest severity level active of the relative equipment (0->9). This can be useful to activate a relay based on the severity level.                                     |
| @(severity_type)      | The highest severity type active of the relative equipment (none - warning - minor - major - critical). This can be useful to activate a relay based on the severity level. |
| @(dcY_severity_level) | The highest severity level active, relative to the DC System with ID Y.                                                                                                     |
| @(saY_severity_level) | The highest severity level active, relative to the equipment Sensors And Actuators with ID Y.                                                                               |

## 12.5 Operators and Functions

| Syntax                                        | Explanation                                                                                                             |
|-----------------------------------------------|-------------------------------------------------------------------------------------------------------------------------|
| (...)                                         | Parentheses                                                                                                             |
| &&                                            | Logical AND                                                                                                             |
|                                               | Logical OR                                                                                                              |
| = or ==                                       | Equal                                                                                                                   |
| !=                                            | Not Equal                                                                                                               |
| +                                             | Addition                                                                                                                |
| -                                             | Subtraction                                                                                                             |
| *                                             | Multiplication                                                                                                          |
| /                                             | Division                                                                                                                |
| >                                             | Superior                                                                                                                |
| >=                                            | Superior or Equal                                                                                                       |
| <                                             | Inferior                                                                                                                |
| <=                                            | Inferior or equal                                                                                                       |
| \$second()                                    | Second part of the actual time                                                                                          |
| \$minute()                                    | Minute part of the actual time                                                                                          |
| \$hour()                                      | Hour part of the actual time                                                                                            |
| \$day()                                       | Integer indicating the day of the month                                                                                 |
| \$dayofweek()                                 | Integer indicating the day of the week. This integer ranges from zero =>indicating Sunday, to six=> indicating Saturday |
| \$dayofyear()                                 | Integer indicating the day of the year                                                                                  |
| \$month()                                     | Integer indicating the month of the year                                                                                |
| \$year()                                      | Integer indicating the year                                                                                             |
| \$time()                                      | The actual time of the day                                                                                              |
| @ts(XX:XX)                                    | Create a timespan variable from XXXX string.<br>Example: @ts(11:30) corresponds to 11:30.                               |
| \$iif(condition, val if true, val if false)   | Equivalent to "If then else"                                                                                            |
| \$abs(XXX)                                    | The absolute value of XXX                                                                                               |
| \$case(condition, val, condition2, val2, ...) | Equivalent to "switch"                                                                                                  |
| \$ceil(XXX)                                   | The ceil value of XXX                                                                                                   |
| \$floor(XXX)                                  | The floor value of XXX                                                                                                  |
| \$max(X1, X2, X3, ...)                        | The maximum value between X1,X2,X3, etc.                                                                                |
| \$min(X1, X2, X3, ...)                        | The minimum value between X1,X2,X3, etc.                                                                                |
| \$sqrt(XXX)                                   | The square root value of XXX                                                                                            |

## 12.6 Examples of Boolean Expressions for Custom PLC Data, Alarms and Relays

### 12.6.1 Create Custom Data

1. Recalculate the voltage of the Converter System AC-out based on apparent power and current.
  - a. Navigate to *SITE > Configuration > PLC* to add a custom PLC data. (There is no PLC configuration possible under the Converter System)

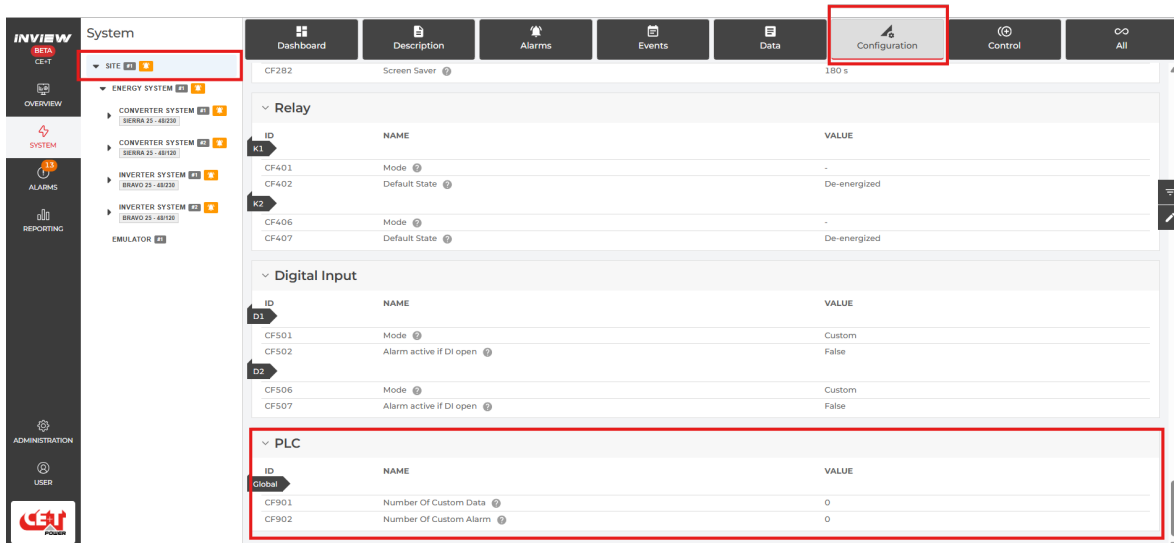

| ID     | NAME                    | VALUE        |
|--------|-------------------------|--------------|
| CF401  | Mode                    | -            |
| CF402  | Default State           | De-energized |
| CF406  | Mode                    | -            |
| CF407  | Default State           | De-energized |
| CF501  | Mode                    | Custom       |
| CF502  | Alarm active if DI open | False        |
| CF506  | Mode                    | Custom       |
| CF507  | Alarm active if DI open | False        |
| Global |                         |              |
| CF901  | Number Of Custom Data   | 0            |
| CF902  | Number Of Custom Alarm  | 0            |

2. Change the parameter CF901 (Number Of Custom Data) to '1'. You will see three new parameters (CF1301, CF1302 and CF1303).
3. Configure the data name, the mathematical expression and the unit.
  - a. Change the name CF1301 (e.g. "AC-out Voltage")
  - b. Change the Mathematical expression CF1302 to " $@(\text{convs1\_da104})/(\text{convs1\_da102})$ "
    - $@(\text{convs1\_da104})$  represents the data with ID 104 of the Converter System: Global AC-output Apparent Power in this case.
    - $@(\text{convs1\_da102})$  represents the data with ID 102 of the Converter System: Global AC-output Current in this case.
  - c. Change the unit CF1303 to 'V'.
4. The custom data is now available under *SITE > Data > PLC*.

### 12.6.2 Create Custom Alarm

1. Adding an overload alarm on an energy meter.
  - a. Navigate to the concerned *Energy Meter > Configuration > PLC*.

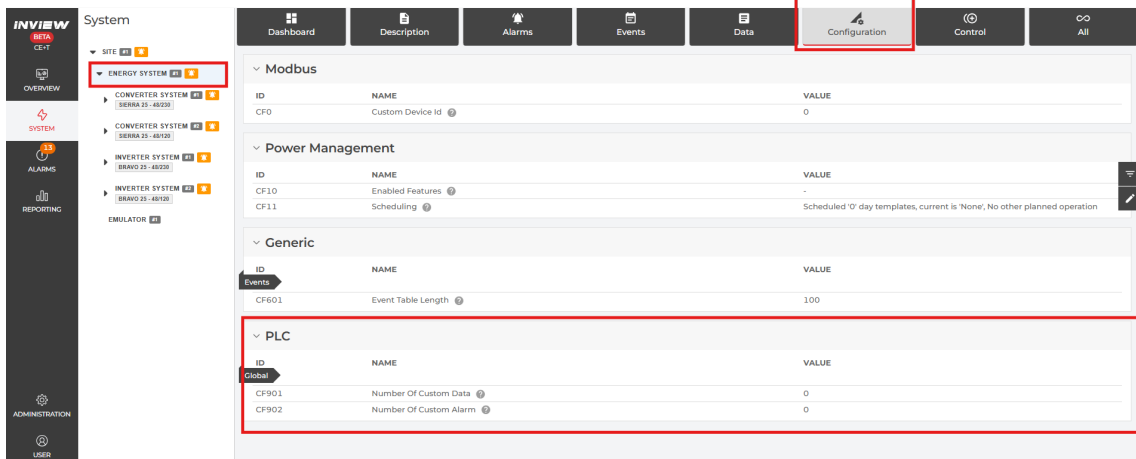

The screenshot shows the Inview CE-IT Configuration page. The 'Configuration' tab is selected in the top navigation bar. The left sidebar shows the 'ENERGY SYSTEM' selected. The main content area displays several configuration sections: Modbus, Power Management, Generic, and PLC. The PLC section is highlighted with a red box and contains the following data:

| ID    | NAME                   | VALUE |
|-------|------------------------|-------|
| CF901 | Number Of Custom Data  | 0     |
| CF902 | Number Of Custom Alarm | 0     |

- b. Change the parameter CF902 (Number Of Custom Alarm) of the energy meter to 1. You will see two new parameters (CF1001, CF1002).
- c. Configure the alarm name and triggering condition.
  - Change the name CF1001 (e.g. "Overload current on line 1 (current > 1A)")
  - Change the Boolean expression CF1002 to "@(da10) >= 1"
    - @(da10) represents the data with ID 10 of this device : Current – Phase 1 in this case.
    - '>=1' compares the data to a value superior or equal to 1.
  - The alarm severity level is 'none' by default. The configuration of the alarm has to be changed under *Energy Meter > Alarms > PLC*. Adapt the severity level for the alarm to be shown.
  - Now, the alarm is triggered (pops up) when the data parameter with ID=10 (DA10) is superior or equal to one, when the current of phase 1 is higher than 1A.

2. Adding a high temperature alarm with a hysteresis.

a. Navigate to *Site > Configuration > PLC* to add a custom PLC alarm.

(There is no PLC configuration possible under Sensors and Actuators (MBB 60V and MBB 500V) on which your temperature sensor is cabled.)

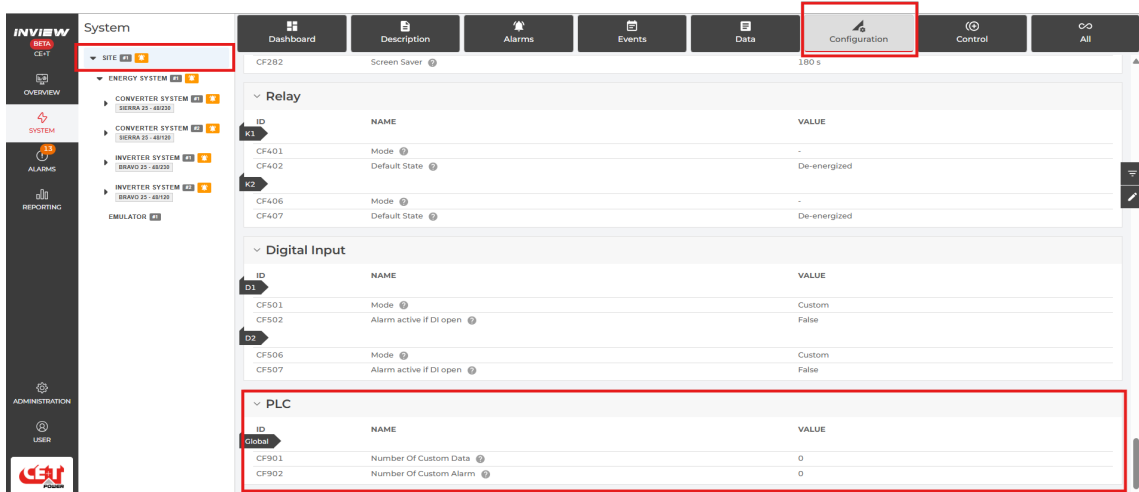

The screenshot shows the INVIEW system configuration interface. The 'Configuration' tab is selected in the top navigation bar. The left sidebar shows the navigation menu with 'SYSTEM' selected. The main content area displays the configuration for a specific site (CF282). The 'Relay' section is expanded, showing a table of relay configurations. Below it, the 'Digital Input' section is also expanded. The 'PLC' section is highlighted with a red box and contains the following table:

| ID     | NAME                   | VALUE |
|--------|------------------------|-------|
| Global |                        |       |
| CF901  | Number Of Custom Data  | 0     |
| CF902  | Number Of Custom Alarm | 0     |

b. Change the parameter CF902 (Number Of Custom Alarm) to 1. You will see two new parameters (CF1001, CF1002).

c. Configure the alarm name and triggering condition.

- Change the name CF1001 (e.g. "Indoor Temperature High")
- Change the Boolean expression CF1002 to  
`"(@sa1_da301)>50) || ((@al101) == True && @(sa1_da301) > 48 )"`
  - The alarm will be triggered if @sa1\_da301 - the temperature DA301 of the Sensors and Actuators #1 - is over 50°C OR if @alarm101 – current alarm - is true and @(data1) is still over 48°C.
  - The alarm severity level is 'none' by default. The configuration of the alarm has to be changed under *Site / Alarms / PLC*. Adapt the severity level for the alarm to be shown.

3. Adding an alarm for the battery being in 'Charge' state.

a. Navigate to *DC System > Configuration > PLC* to add a custom PLC alarm.

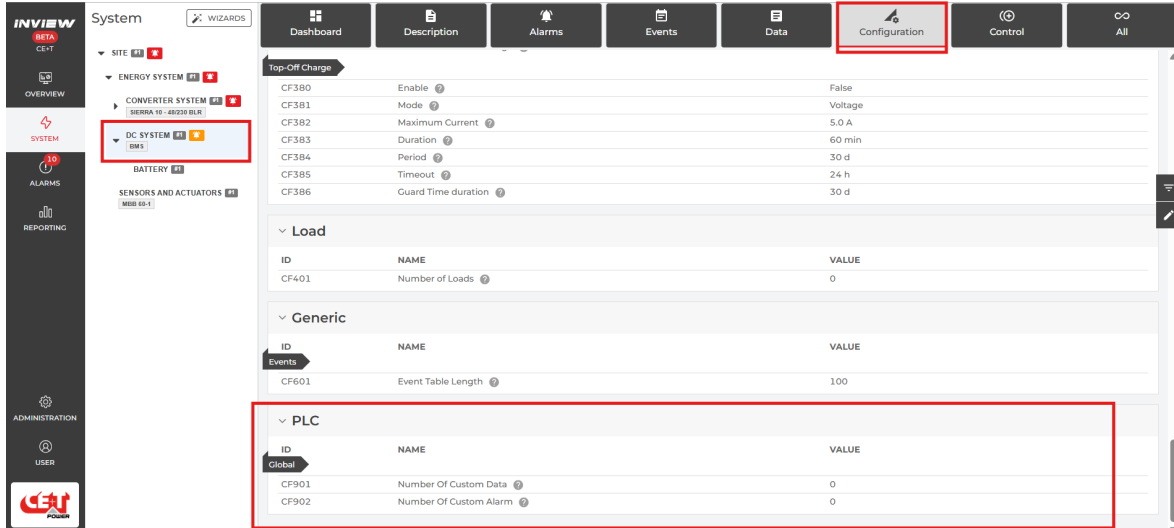

b. Change the parameter CF902 (Number Of Custom Alarm) to 1. You will see two new parameters (CF1001, CF1002).

c. Configure the alarm name and triggering condition.

- Change the name CF1001 (e.g. "Battery in Charge")
- Change the Boolean expression CF1002 to "@(da1)=2"
  - The alarm will be triggered if @(da1) - the Battery state DA1 of the DC System - is equal to 2.
  - The possible values of DA1 are:
    - 0 = Unknown
    - 1 = Disconnected
    - 2 = Charge
    - 3 = Discharge
    - 4 = Warning
    - 5 = Error
- The alarm severity level is 'none' by default. The configuration of the alarm has to be changed under *DC System > Alarms > PLC*. Adapt the severity level for the alarm to be shown.

### 12.6.3 Create Custom Relay

1. Based on a mathematical expression: Relay for starting and stopping of a genset based on the Voltage of the Battery.

Note: The easiest way to do this is by creating an alarm and assigning the alarm to a relay.

- a. Navigate to *DC System > Configuration > PLC* to add a custom PLC alarm.

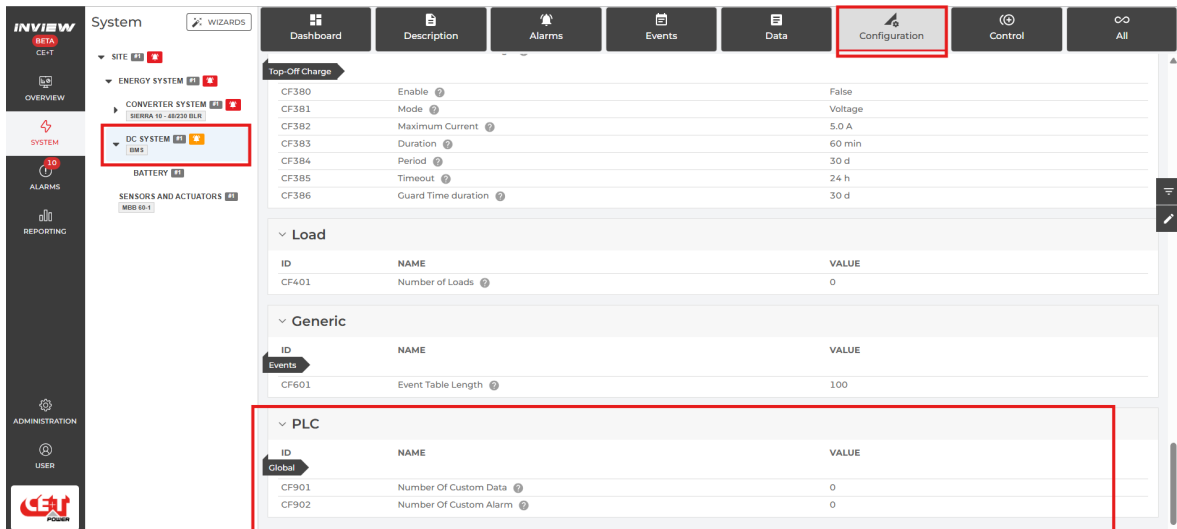

The screenshot shows the INVIEW System Configuration interface. The left sidebar has 'DC SYSTEM' selected. The main content area is under 'Configuration' and shows a table of parameters. The 'PLC' section is highlighted with a red box and contains the following data:

| ID     | NAME                   | VALUE |
|--------|------------------------|-------|
| Global |                        |       |
| CF901  | Number Of Custom Data  | 0     |
| CF902  | Number Of Custom Alarm | 0     |

- b. Change the parameter CF902 (Number of Custom Alarm) to 1. You will see two new parameters (CF1001, CF1002).

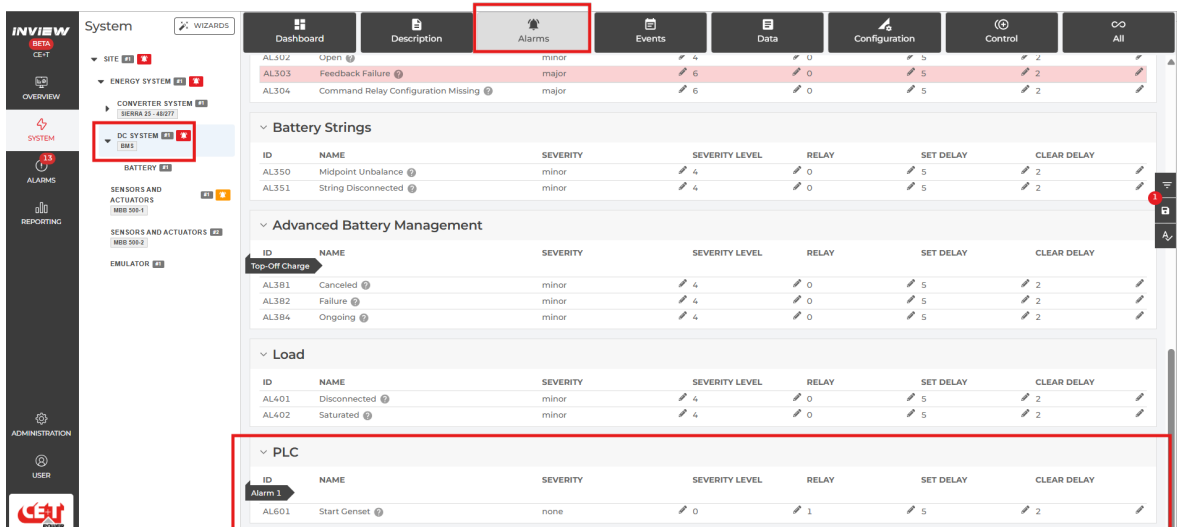

The screenshot shows the INVIEW System Alarms interface. The left sidebar has 'DC SYSTEM' selected. The main content area is under 'Alarms' and shows a table of alarms. The 'PLC' section is highlighted with a red box and contains the following data:

| ID      | NAME         | SEVERITY | SEVERITY LEVEL | RELAY | SET DELAY | CLEAR DELAY |
|---------|--------------|----------|----------------|-------|-----------|-------------|
| Alarm 1 |              |          |                |       |           |             |
| AL601   | Start Genset | none     | 0              | 1     | 5         | 2           |

- c. Configure the alarm name and triggering condition.

- Change the name CF1001 (e.g. "Start Genset")
- Change the Boolean expression CF1002 to  $((@(\text{da}60) \leq 47) \vee (@(\text{al}601) \&\& @(\text{da}60) \leq @(\text{da}18) - 0.1) \&\& @(\text{da}61) < -1 \vee @(\text{da}61) > @(\text{da}19) / 10))$ .
  - The alarm will be triggered if @(\text{da}60) - the Battery voltage DA60 of the DC System - is less than 47V OR if the alarm is already active (@(\text{al}601)) and the Battery voltage DA60 is less than the target

voltage  $-0.1V (@da60) \leq (@da18) - 0.1$ ) and the measured current is less than  $-1A (@da61) < -1$ ) or the measured current is above 10% of the maximum charging current limit  $(@da61) > (@da19)/10$ ).

- The alarm severity level is 'none' by default. The change the alarm configuration under *DC System > Alarms > PLC*. Adapt the severity level for the alarm to be shown. Assign the alarm AL601 to the virtual relay 1.

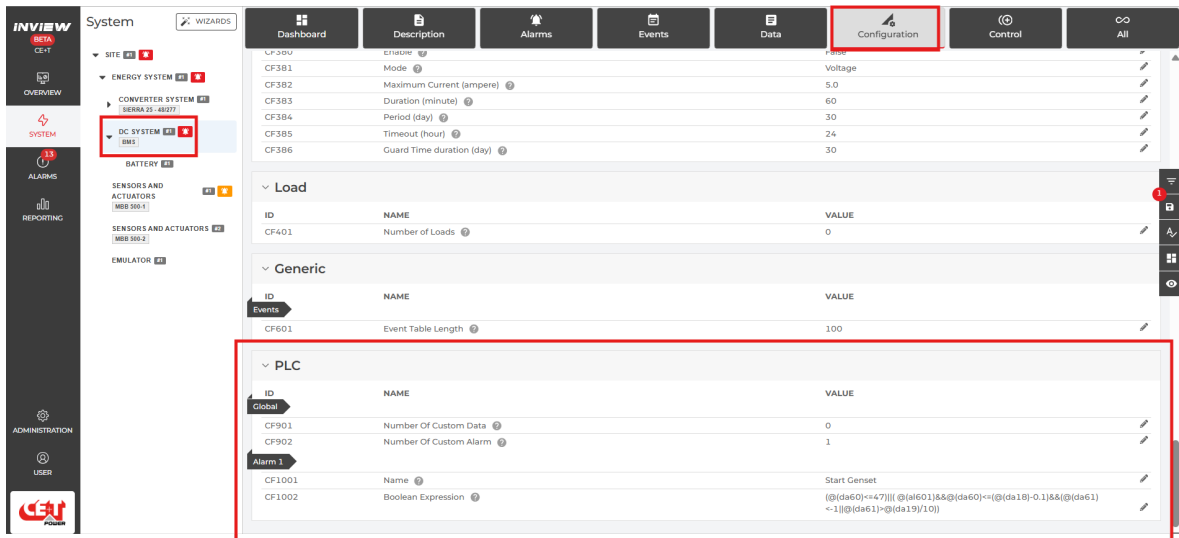

The screenshot shows the INVIEW System Configuration interface. The 'Configuration' tab is selected. The 'PLC' section is expanded, showing a table of PLC configurations. The 'Alarm 1' section is highlighted with a red box, showing the following configuration:

| ID     | NAME               | VALUE                                                                                       |
|--------|--------------------|---------------------------------------------------------------------------------------------|
| CF1001 | Name               | Start Genset                                                                                |
| CF1002 | Boolean Expression | $(@da60) < -1$    $(@a601) \& \& (@da60) < -1$    $(@da18) - 0.1$    $(@da61) > (@da19)/10$ |

d. In case, relay connected to inview or MBB.

- If relay is on Inview, navigate to *SITE > Configuration > Relay*.
  - If relay is on MBB, navigate to *Sensors and Actuators > Configuration > Relay*.
- e. Set the mode of the corresponding relay to 'GlobalRelay(1)'.

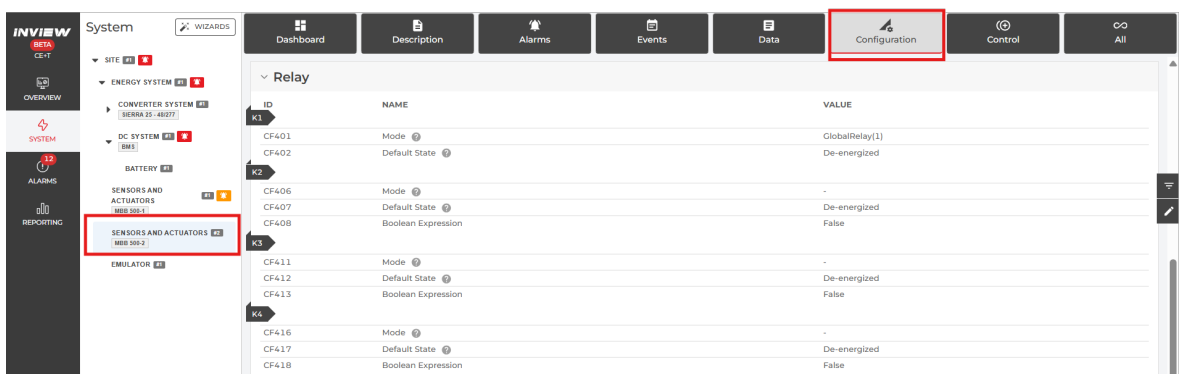

The screenshot shows the INVIEW System Configuration interface. The 'Configuration' tab is selected. The 'Relay' section is expanded, showing a table of relay configurations. The 'Sensors and Actuators' section is highlighted with a red box. The 'Relay' table is as follows:

| ID    | NAME               | VALUE          |
|-------|--------------------|----------------|
| CF401 | Mode               | GlobalRelay(1) |
| CF402 | Default State      | De-energized   |
| CF406 | Mode               | -              |
| CF407 | Default State      | De-energized   |
| CF408 | Boolean Expression | False          |
| CF411 | Mode               | -              |
| CF412 | Default State      | De-energized   |
| CF413 | Boolean Expression | False          |
| CF416 | Mode               | -              |
| CF417 | Default State      | De-energized   |
| CF418 | Boolean Expression | False          |

### 2. Based on a custom expression.

- If the relay is on Inview, navigate to *SITE > Configuration > Relay*.
- If the relay is on MBB, navigate to *Sensors and Actuators > Configuration > Relay*.
  - a. Set the mode of the corresponding relay to 'Custom'. Change the Boolean expression to the desired condition.

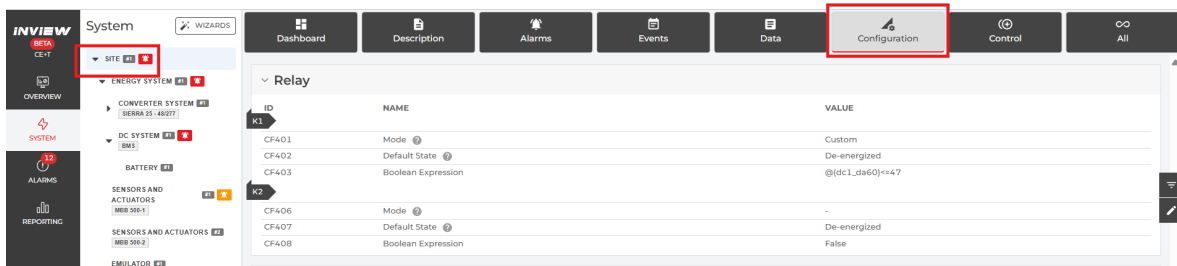

### 3. Based on severity level

- If the relay is on Inview, navigate to *SITE > Configuration > Relay*.
- If the relay is on MBB, navigate to *Sensors and Actuators > Configuration > Relay*.
  - a. Set the mode of the corresponding relay to 'Custom'.
  - b. Click Edit and type “@(dc1\_severity\_level)>=2” in the Boolean Expression box.

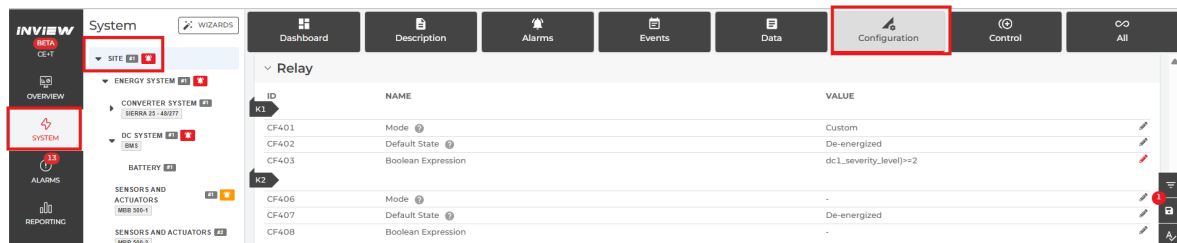

- @(dc1\_severity\_level) correspond to the highest severity level active among the alarms of DC System #1.
- @(dc1\_severity\_level)=2 will not trigger the relay, If the alarm with severity level 2 or higher severity level are active in the DC System. All the element under the DC System #1 determines the alarms highest severity level.

### 4. Based on severity type.

- If the relay is on Inview, navigate to *SITE > Configuration > Relay*.
- If the relay is on MBB, navigate to *Sensors and Actuators > Configuration > Relay*.
  - a. Set the mode of the corresponding relay to 'Custom'.

b. Click Edit and type “@dc1\_severity\_type)>=“major” in the Boolean expression box..

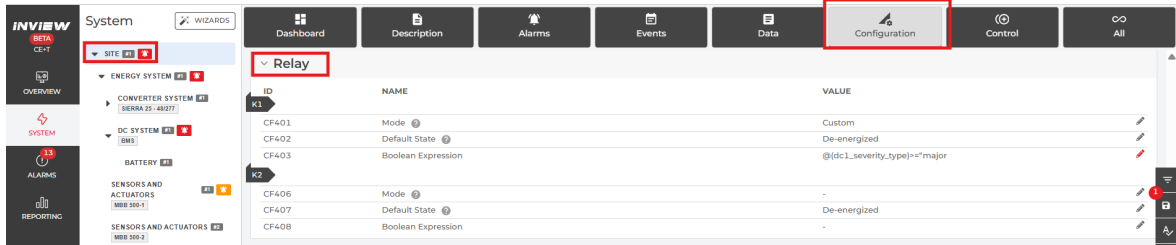

- @dc1\_severity\_type) correspond to the highest severity type active among all alarms of DC System #1.
- Pay attention that @(dc1\_severity\_type)= “minor” will not Energize the relay if there are both alarms with a severity type of “minor” and alarms with higher severity types that are active in the DC System #1. All elements under DC System #1 are considered to determine the highest severity type.

#### 12.6.4 Simple Examples of Custom Alarms or Data

| Condition or Data                                        | Configuration examples                                                                                                                                                                                                                                                                                                                                                                  |
|----------------------------------------------------------|-----------------------------------------------------------------------------------------------------------------------------------------------------------------------------------------------------------------------------------------------------------------------------------------------------------------------------------------------------------------------------------------|
| The bus voltage is under 47V.                            | @(data11)<47                                                                                                                                                                                                                                                                                                                                                                            |
| If the specific inverter output power is over 2500W      | @(convs1_co1_data13)>2500                                                                                                                                                                                                                                                                                                                                                               |
| The time of the day is comprised between 10:30 and 11:30 | (\$time())>@ts(10:30))&&(\$time())<@ts(11:30))                                                                                                                                                                                                                                                                                                                                          |
| The day of the week is Sunday                            | \$dayofweek()==0                                                                                                                                                                                                                                                                                                                                                                        |
| The alarm with ID 17 is active                           | @(alarm17) ==True                                                                                                                                                                                                                                                                                                                                                                       |
| The alarm with ID 17 and 18 are active                   | @(alarm17) ==True && @(alarm18) ==True                                                                                                                                                                                                                                                                                                                                                  |
| Linking Digital input with relay                         | <ul style="list-style-type: none"> <li>• If Digital input 3 is closed then relay K3 need to be energized. <ul style="list-style-type: none"> <li>▪ D3 alarm ID from Inview: al511</li> <li>▪ Boolean expression set at relay : @(sa1_al511)</li> </ul> </li> <li>• Mode: Custom; Boolean Expression: @(sa1_al511)</li> </ul>                                                            |
| Linking Specific alarm with Relay                        | <ul style="list-style-type: none"> <li>• If Redundancy lost alarm need to be configured with relay <ul style="list-style-type: none"> <li>▪ Redundancy lost alarm ID from Inview: al103</li> <li>▪ Boolean expression need to be set at relay: @(convs1_al103)</li> </ul> </li> <li>• Mode: Custom; Boolean Expression: @(convs1_al103)</li> </ul>                                      |
| Linking Specific data with Relay                         | <ul style="list-style-type: none"> <li>• When the battery voltage reaches below 45V <ul style="list-style-type: none"> <li>▪ Battery voltage measurement displayed at: sensors and actuators &gt; Data&gt; da101</li> <li>▪ Boolean expression need to be set at relay: @(sa1_al101)&lt;45</li> </ul> </li> <li>• Relay Mode: Custom; Boolean Expression: @(sa1_da101)&lt;45</li> </ul> |

## 13. Annexe 3: Inview - Software Upgrade

The current software version number is present on [User Context > About](#). To know more about software details, navigate to [SYSTEM > SITE > Description](#) and scroll down to the Controller section.

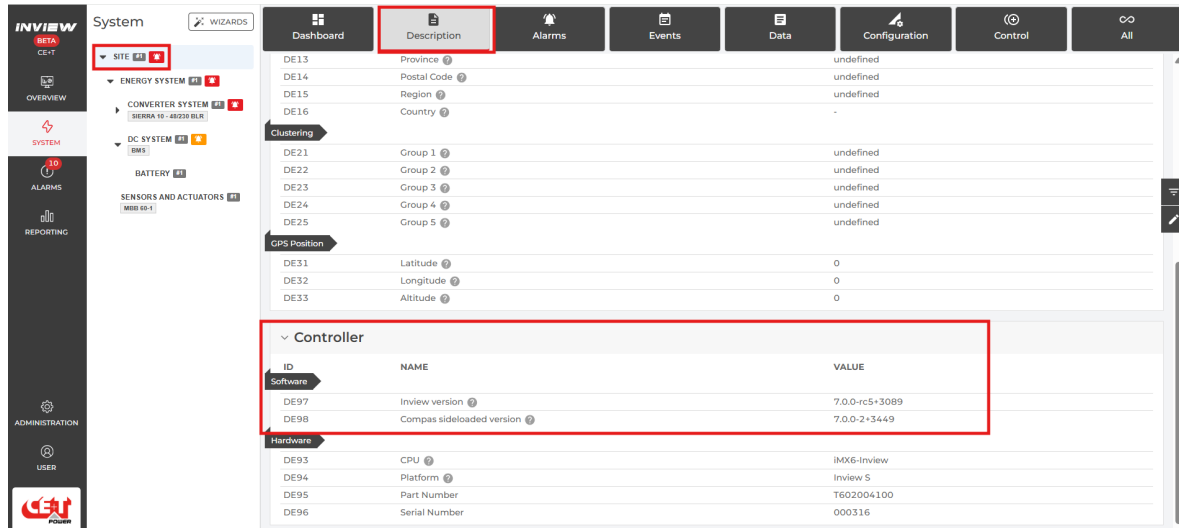

| ID              | NAME                       | VALUE          |
|-----------------|----------------------------|----------------|
| <b>Software</b> |                            |                |
| DE97            | Inview version             | 7.0.0-rc5+3089 |
| DE98            | Compass sideloaded version | 7.0.0-2+3449   |
| <b>Hardware</b> |                            |                |
| DE93            | CPU                        | IMX6-Inview    |
| DE94            | Platform                   | Inview S       |
| DE95            | Part Number                | T602004100     |
| DE96            | Serial Number              | 000316         |

Perform the following steps to upgrade Inview software, and this process can do only through the web interface.

1. Navigate to [my.cet-power.com](http://my.cet-power.com) > [Documents](#) > [Download SOFT](#) > [2\\_MONITORING AND CONTROLS](#) (link) and download the latest software from the [4\\_INVIEW](#) folder. The downloaded file will be “.RAR”, extract and save it in local as “.UPG” extension.

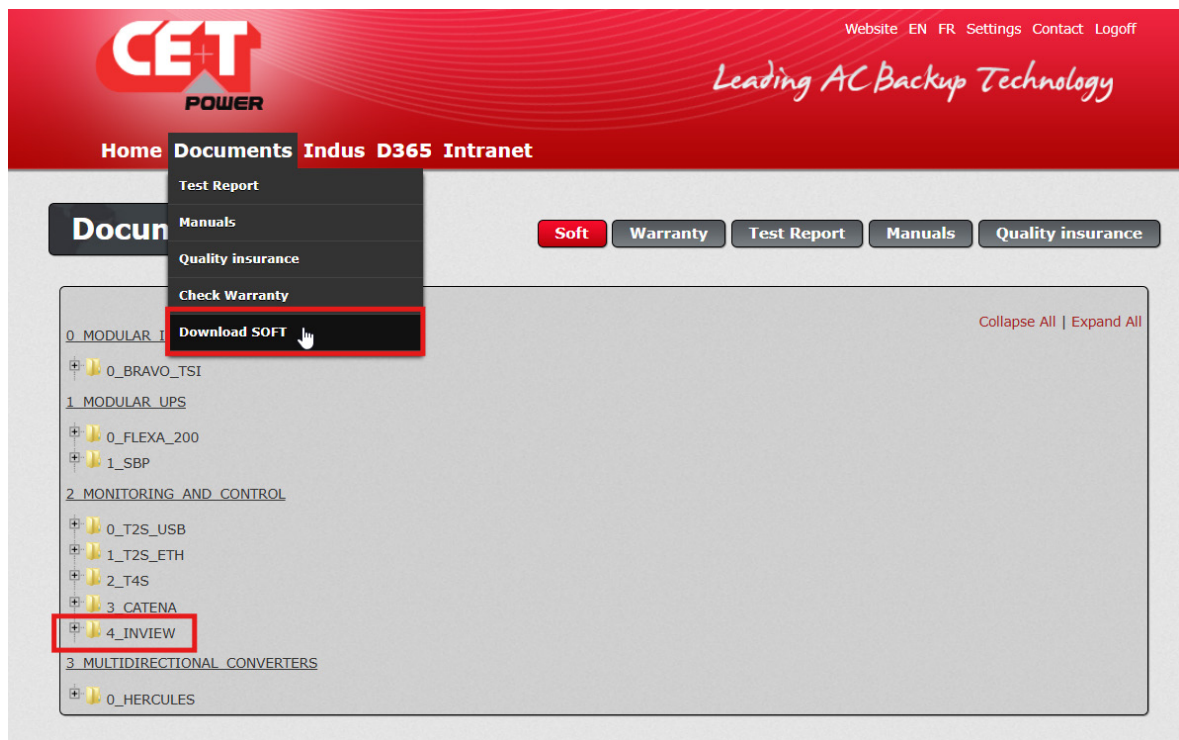

Website EN FR Settings Contact Logoff

Leading AC Backup Technology

Home Documents Indus D365 Intranet

Docun

- Test Report
- Manuals
- Quality insurance
- Check Warranty
- Download SOFT**

0 MODULAR 1

- 0\_BRAVO\_TSI
- 1 MODULAR UPS
  - 0\_FLEXA\_200
  - 1\_SBP
- 2 MONITORING AND CONTROL
  - 0\_T2S\_USB
  - 1\_T2S\_ETH
  - 2\_T4S
  - 3 CATENA
  - 4\_INVIEW**
- 3 MULTIDIRECTIONAL CONVERTERS
  - 0\_HERCULES

Soft Warranty Test Report Manuals Quality insurance

Collapse All | Expand All

2. Login as admin privileged account in the Inview web interface and Navigate to *Administration > Software Update*.

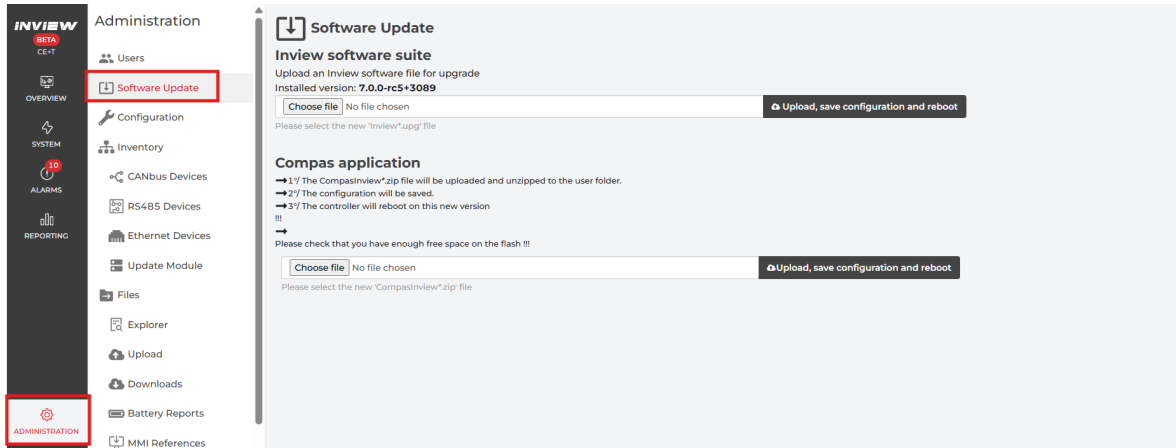

3. Click “Choose file” button and direct to the downloaded .UPG file and the Click “Upload, save configuration and reboot” button.

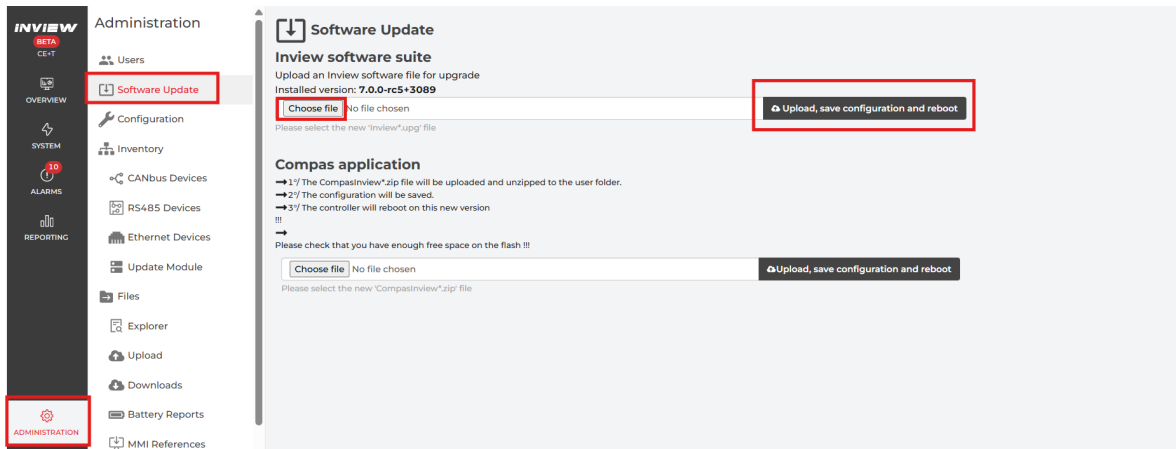

4. Wait, the upgrading process will take approximately 15 minutes to return to normal operating conditions.
5. After successful up-gradation, the web interface resumes to the login screen. Login and verify the Software version below the Inview logo or navigate to the *Controller* section at *SYSTEM > SITE > Description* page.

**Note:** During the upgrade, it is highly recommended to ensure that the Inview does not get shut down (it might get bricked). Therefore, it is recommended to use a redundant power supply.

# 14. Annexe 4: Hardware Replacement

## 14.1 Inview Slot, S, X, X+ and XC

Before replacing the new Inview Slot, S, X, X+ or XC, the existing configuration file must be saved and need to upload the same after installing the new controller.

**Perform the following steps for replacing Inview Slot, S, X, X+ or XC:**

1. Login as admin privileged account, navigate to *Administration > Configuration*, click “Download configuration file” button, and save the file in local.

*Note: The downloaded file name will be as “configuration.xml” and it must not be renamed.*

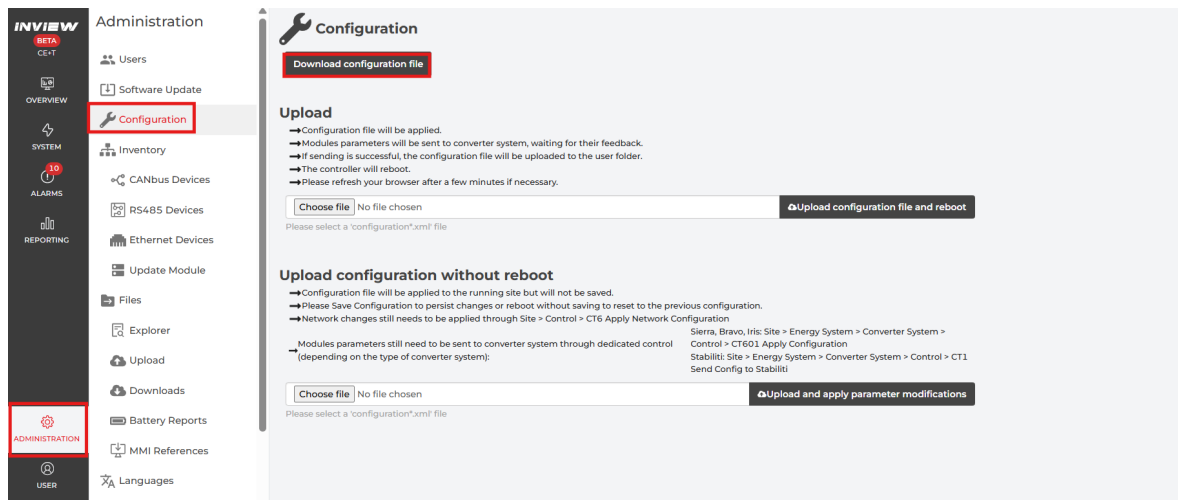

2. Remove the existing controller and install the new controller. To know about installing it and its hardware connections, refer to the section 5, page 20.
3. Power on the controller and login as admin privileged account.
4. Navigate to *Administration > Configuration*, click “Choose file” button, and direct to the downloaded “configuration.xml” file. Then click “Upload configuration and reboot” button.

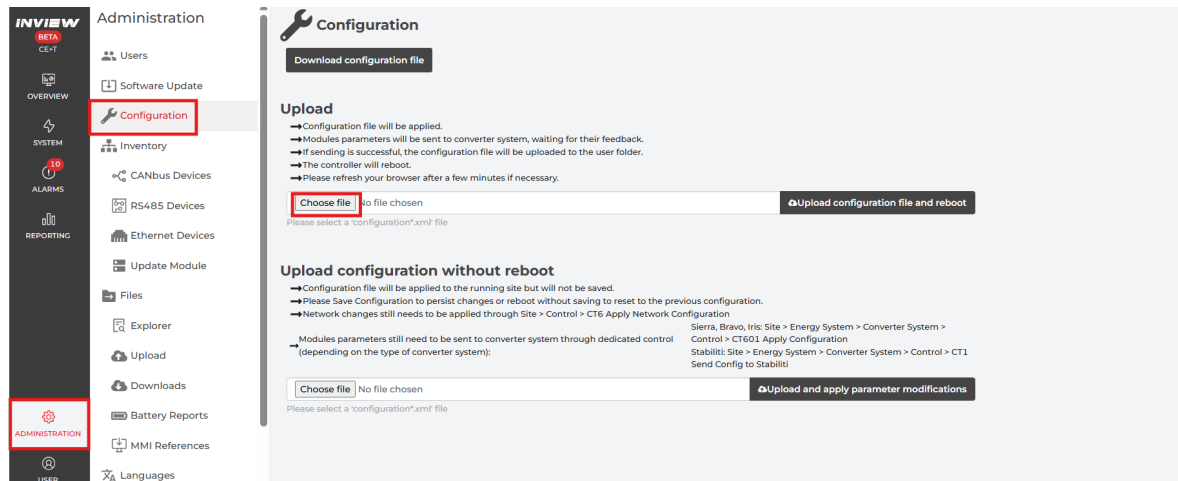

## 14.2 Accessories - MBB 60V / MBB 500V

Perform the following steps for replacing MBB 60V / MBB 500V:

1. Remove the existing MBB from the system.
2. Clear from the inventory list: Navigate to *SYSTEM > SITE > Control*, scroll down to the *Inventory* section. In the ID CT61 (Clean Equipment Inventory), click the  icon to clear it from the list.

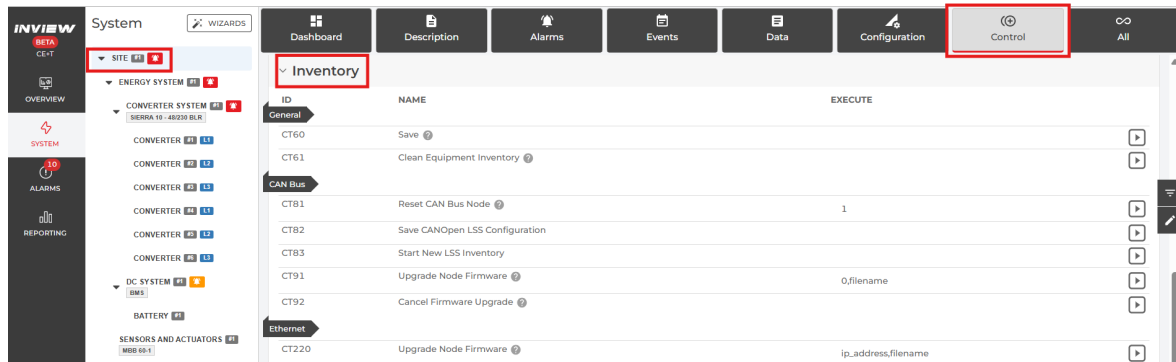

| ID              | NAME                           | EXECUTE             |
|-----------------|--------------------------------|---------------------|
| <b>General</b>  |                                |                     |
| CT60            | Save                           |                     |
| CT61            | Clean Equipment Inventory      |                     |
| <b>CAN Bus</b>  |                                |                     |
| CT81            | Reset CAN Bus Node             | 1                   |
| CT82            | Save CANOpen LSS Configuration |                     |
| CT83            | Start New LSS Inventory        |                     |
| CT91            | Upgrade Node Firmware          | 0,filename          |
| CT92            | Cancel Firmware Upgrade        |                     |
| <b>Ethernet</b> |                                |                     |
| CT220           | Upgrade Node Firmware          | ip_address,filename |

3. Connect the new MBB in the system. To know about the hardware connections, refer to the section 5.6, page 23.
4. Once the MBB is powered on, make sure it was detected and listed in the “Sensors and Actuators” list.
5. Navigate to *SYSTEM > Sensors and Actuators*, scroll down to *Relay* and *Digital Input* sections, and verify that the mappings are done correctly.

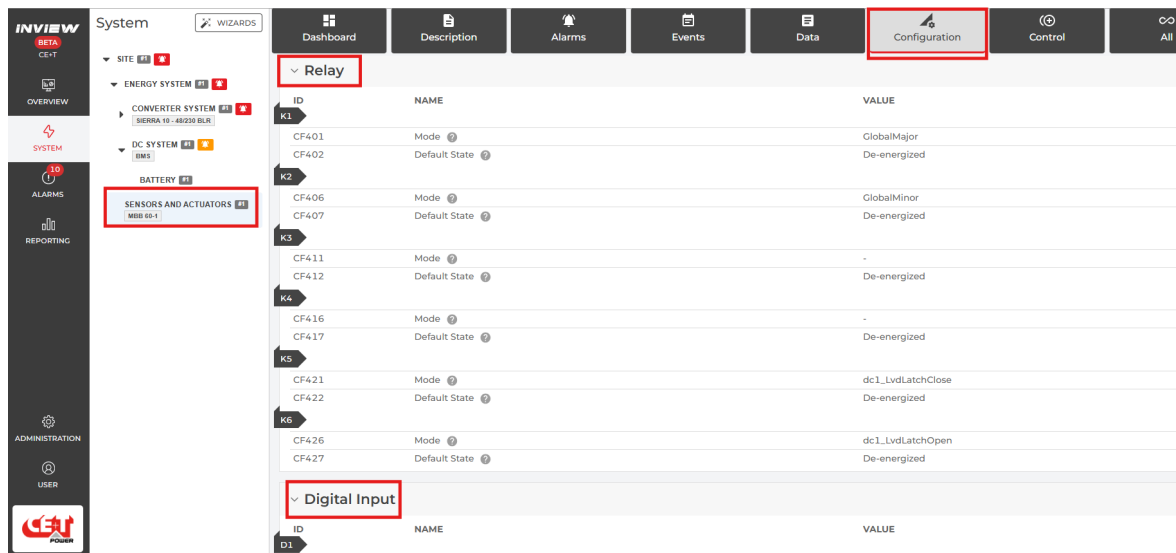

| ID                   | NAME          | VALUE             |
|----------------------|---------------|-------------------|
| <b>K1</b>            |               |                   |
| CF401                | Mode          | GlobalMajor       |
| CF402                | Default State | De-energized      |
| <b>K2</b>            |               |                   |
| CF406                | Mode          | GlobalMinor       |
| CF407                | Default State | De-energized      |
| <b>K3</b>            |               |                   |
| CF411                | Mode          | -                 |
| CF412                | Default State | De-energized      |
| <b>K4</b>            |               |                   |
| CF416                | Mode          | -                 |
| CF417                | Default State | De-energized      |
| <b>K5</b>            |               |                   |
| CF421                | Mode          | dc1_LvdLatchClose |
| CF422                | Default State | De-energized      |
| <b>K6</b>            |               |                   |
| CF426                | Mode          | dc1_LvdLatchOpen  |
| CF427                | Default State | De-energized      |
| <b>Digital Input</b> |               |                   |
| ID                   | NAME          | VALUE             |
| D1                   |               |                   |

# 15. Annexe 5: Wiring Diagrams

## 15.1 Inview Slot with MBB

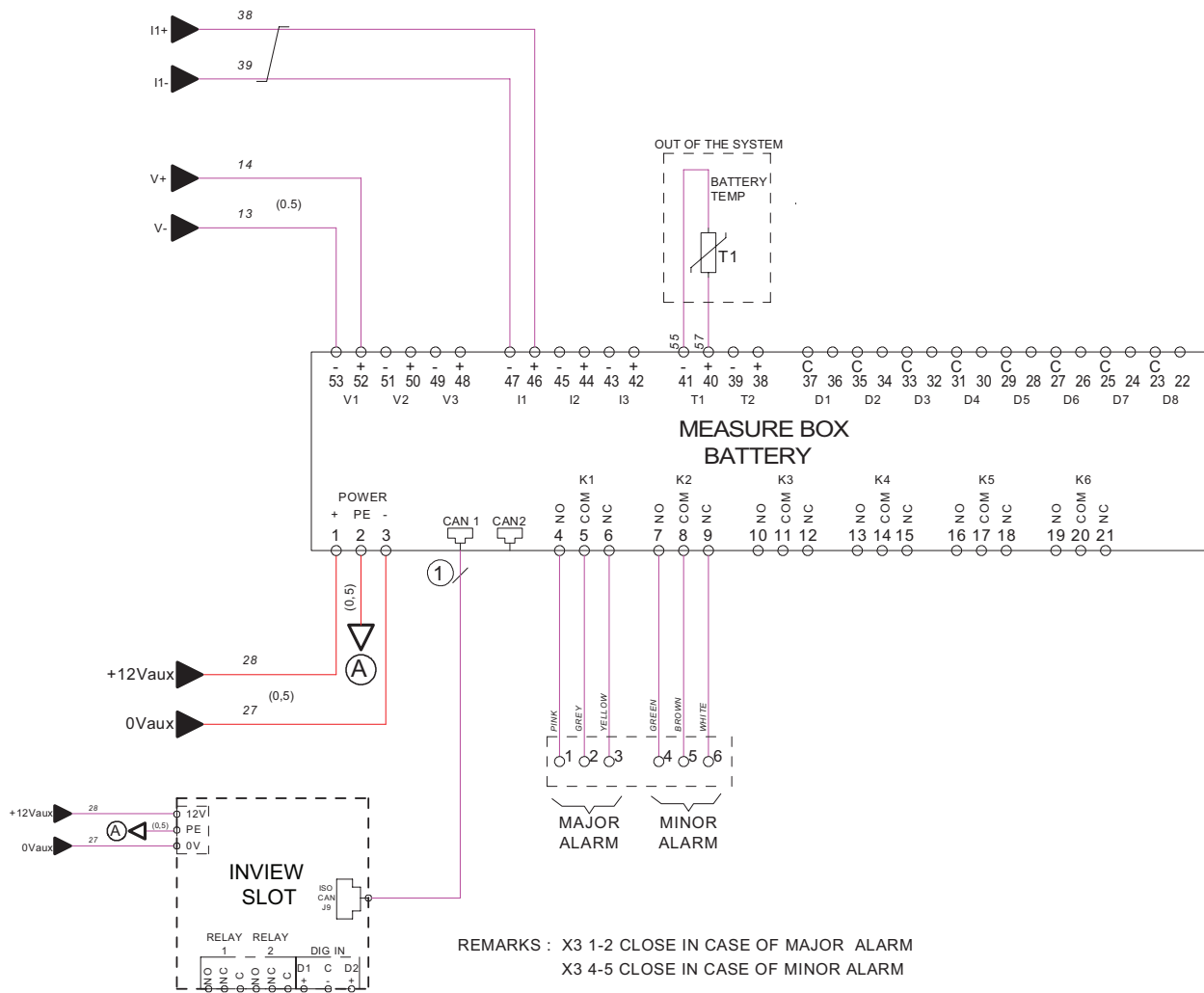

**Note:** The schematic corresponds to MBB 60V; it is similar for MBB 500V except that V3, I3, K5 and K6 do not exist on MBB 500V.

## 15.2 Inview S with MBB

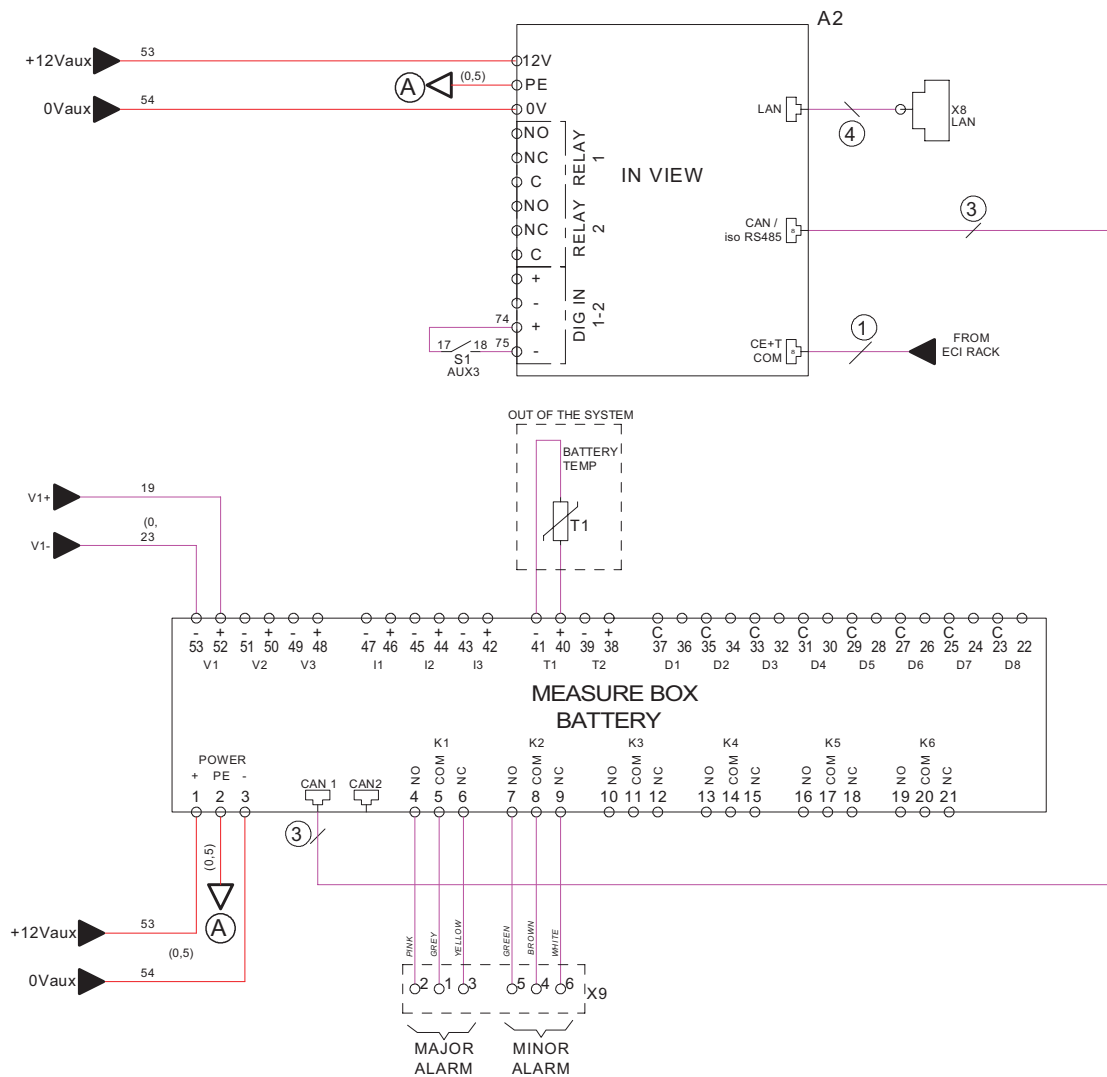

REMARKS : X9 1-2 CLOSE IN CASE OF MAJOR ALARM  
X9 4-5 CLOSE IN CASE OF MINOR ALARM

**Note:** The schematic corresponds to MBB 60V; it is similar for MBB 500V except that V3, I3, K5 and K6 do not exist on MBB 500V.

**15.3 Inview X / X+ with MBB**

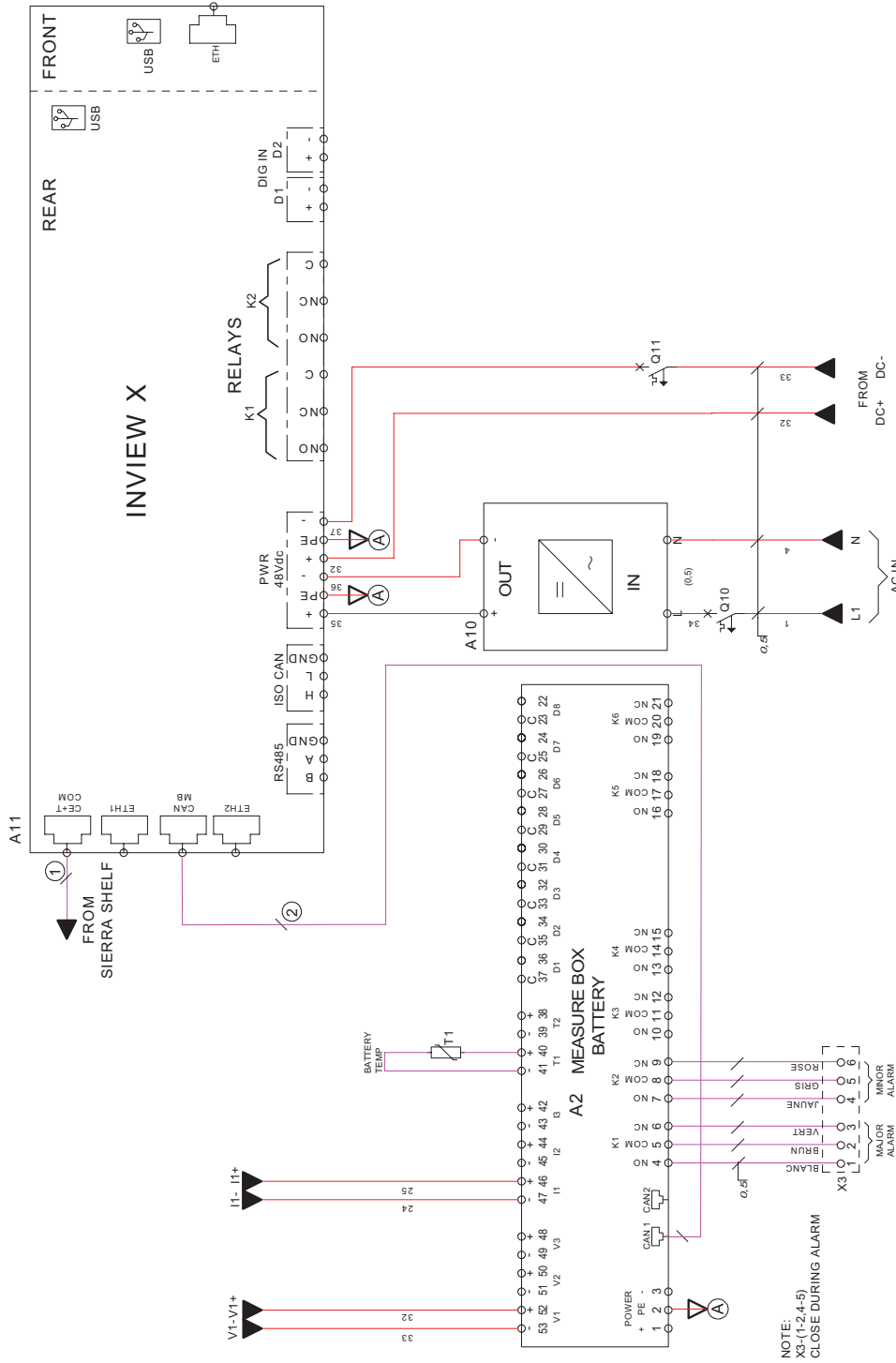

**Note:** The schematic corresponds to MBB 60V; it is similar for MBB 500V except that V3, I3, K5 and K6 do not exist on MBB 500V.

### 15.4 Inview XC with MBB

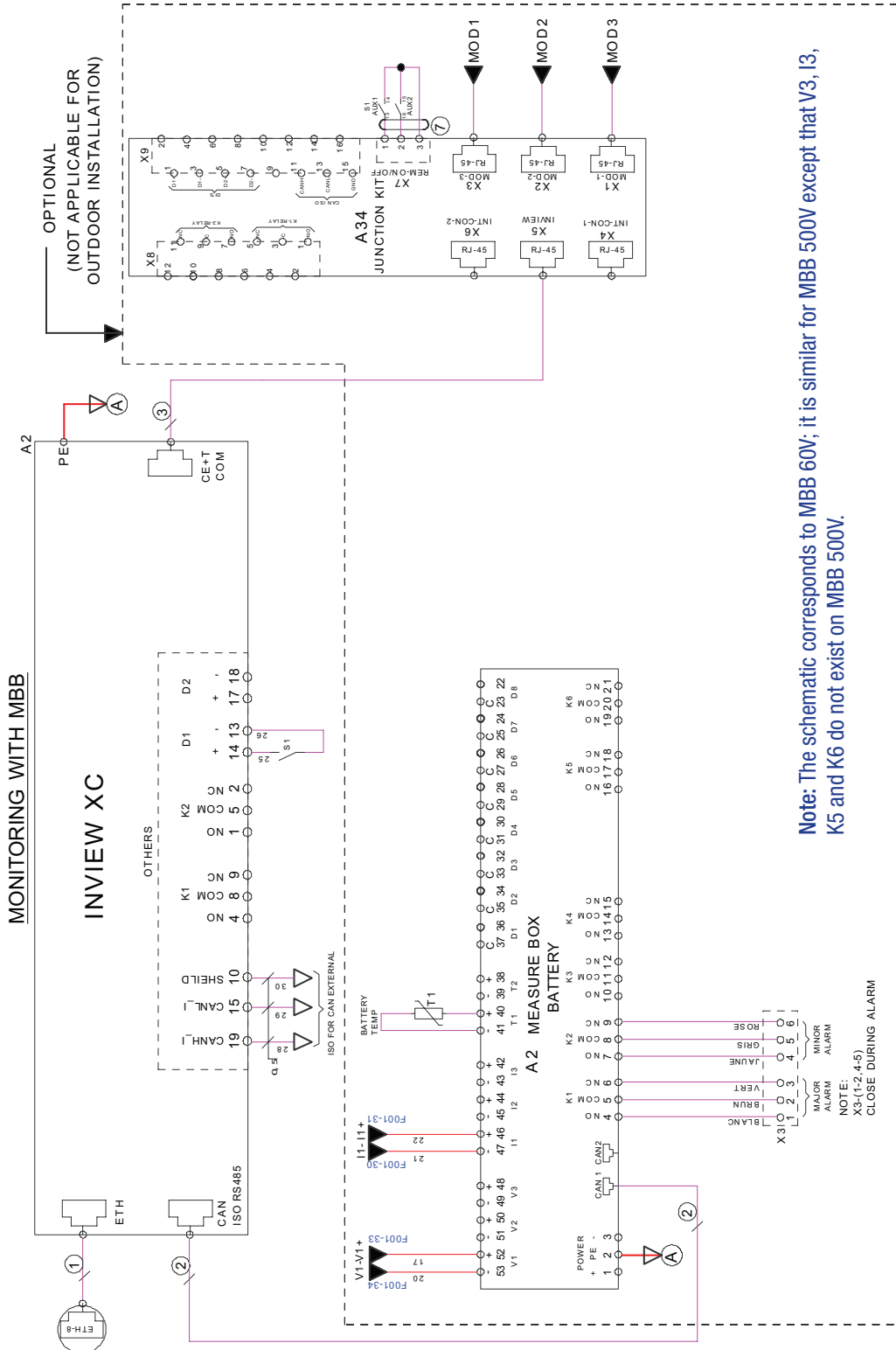

## 16. Annexe 6: Auxiliary power supply kit

### 16.1 Auxiliary power supply kit with Din Rail

| S.No | Model   | Part number |
|------|---------|-------------|
| 1    | 48 Vdc  | T602004122  |
| 2    | 110 Vdc | T602004124  |
| 3    | 380 Vdc | T602004123  |

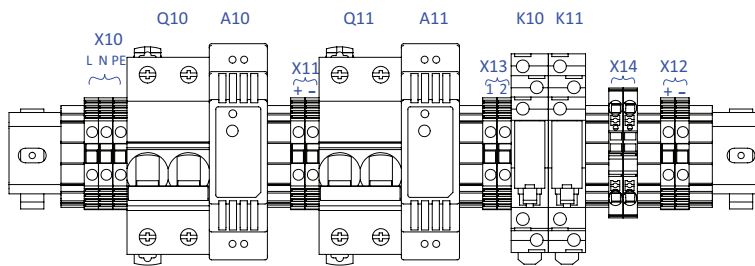

- X10 - AC input terminal (1P)
- X11 - DC input terminal (Battery voltage)
- X12 - DC Output terminal (12 V DC)
- X13 - Alarm contact for Aux power supply unit fail
- X14 - Diodes

Front View

### 16.2 Auxiliary power supply kit - Wiring diagram

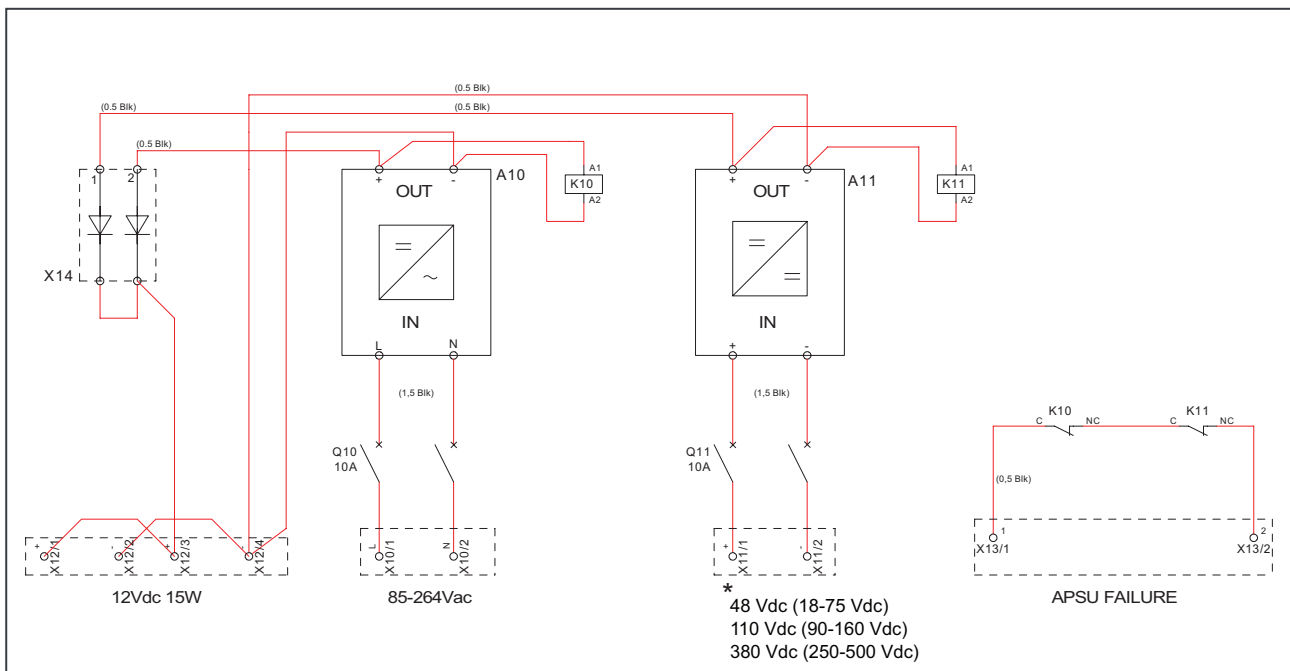

# 17. Annexe 7: Inview Panel Sheets

## 17.1 Inview S - Panel Sheets

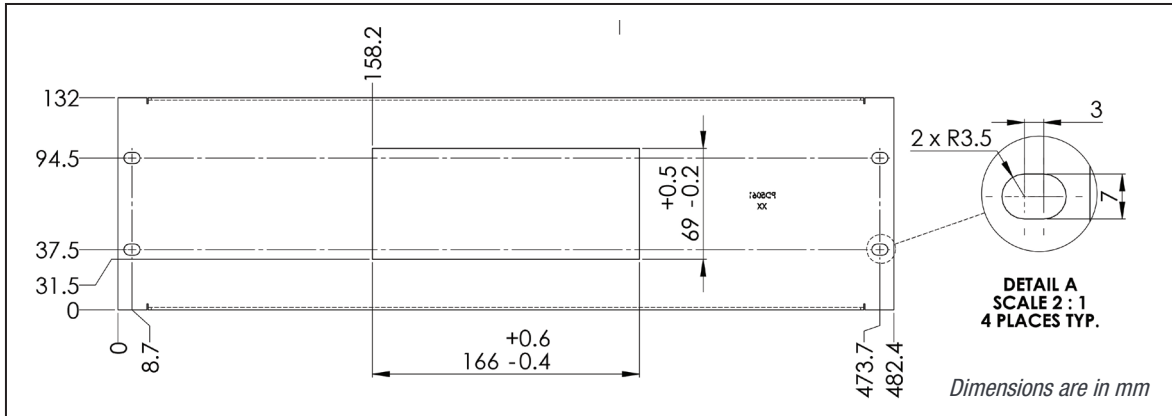

3U Panel sheet - cut out details

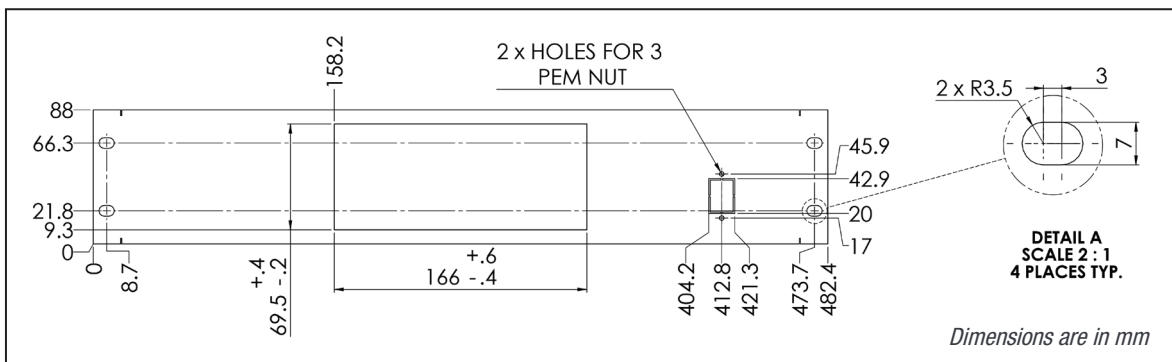

2U Panel sheet (center)- cut out details

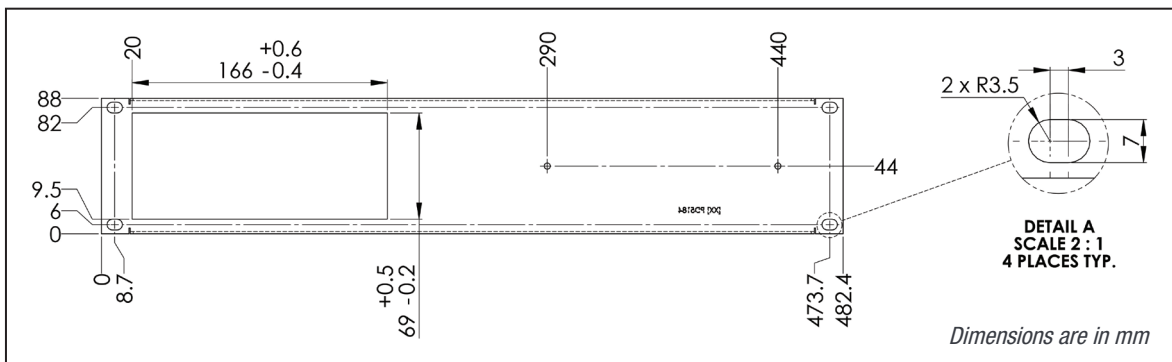

2U Panel sheet (left)- cut out details

**17.2 Inview X / X+ - Panel Sheet**

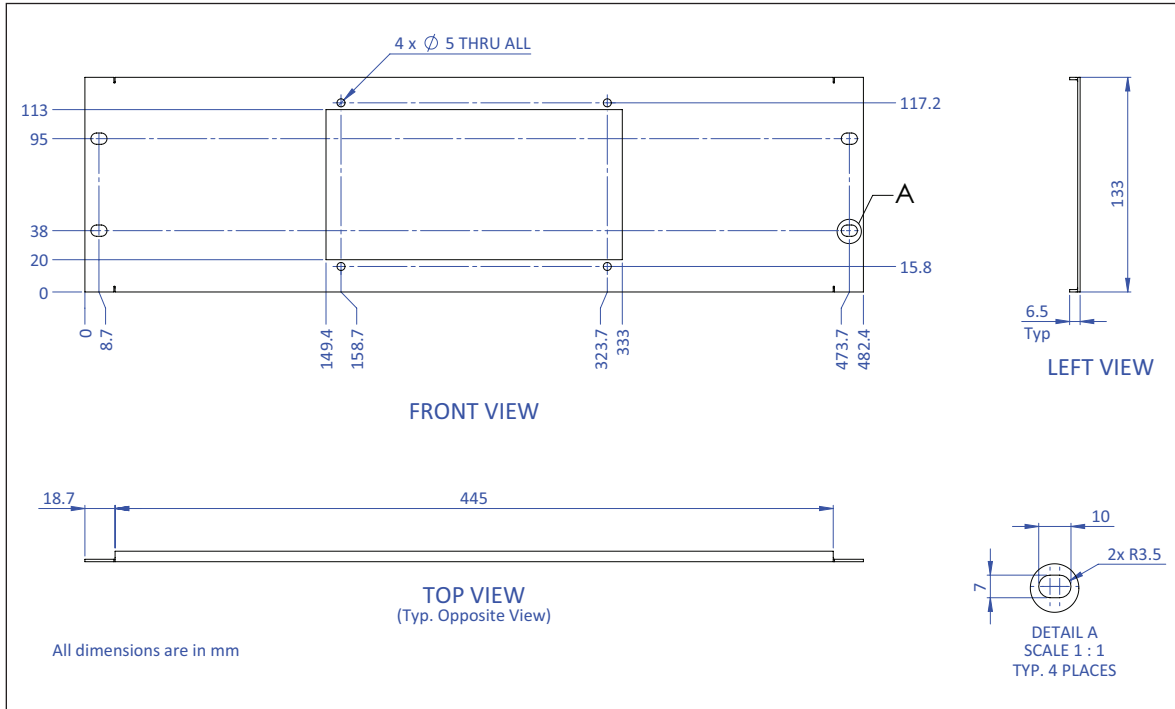

**17.3 Inview XC - Dimensions**

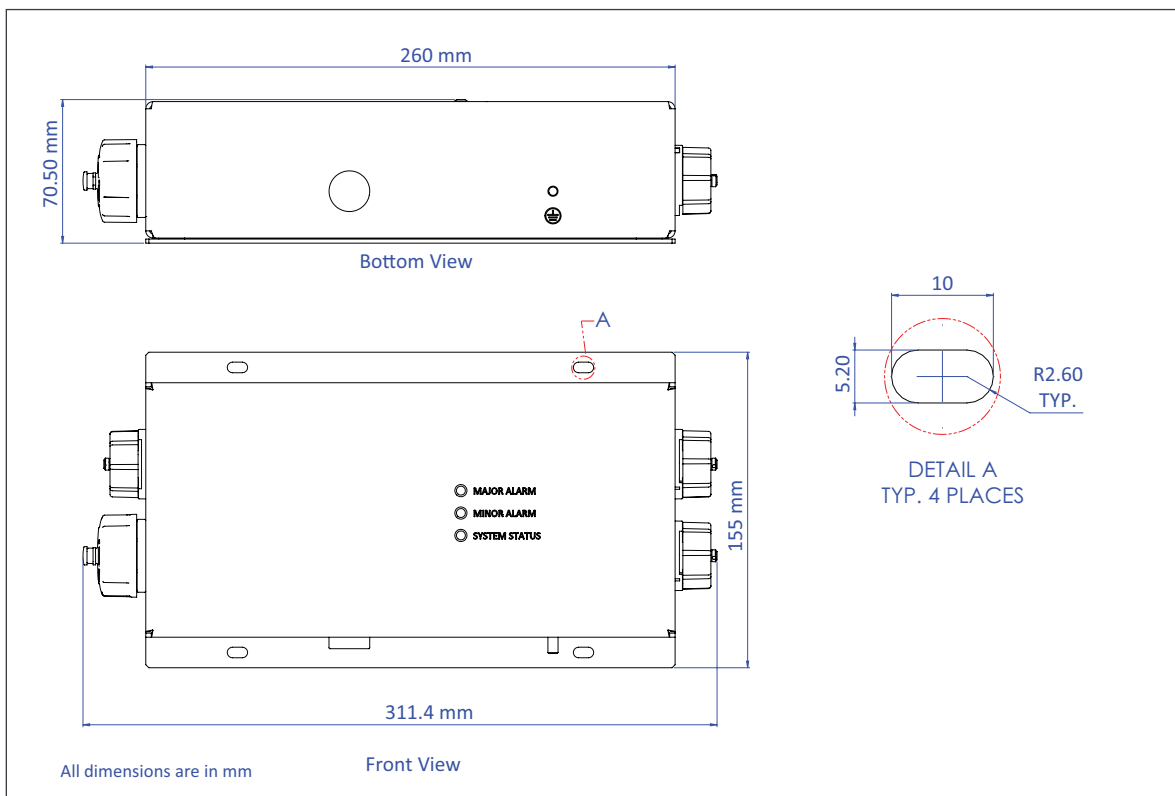

## Disclaimer

### USA:

#### Federal Communications Commission (FCC) Statement 15.105(b)

This equipment has been tested and found to comply with the limits for a Class B digital device, pursuant to part 15 of the FCC rules. These limits are designed to provide reasonable protection against harmful interference in a residential installation.

This equipment generates, uses and can radiate radio frequency energy and, if not installed and used in accordance with the instructions, may cause harmful interference to radio communications. However, there is no guarantee that interference will not occur in a particular installation. If this equipment does cause harmful interference to radio or television reception, which can be determined by turning the equipment off and on, the user is encouraged to try to correct the interference by one or more of the following measures:

- Reorient or relocate the receiving antenna.
- Increase the separation between the equipment and receiver.
- Connect the equipment into an outlet on a circuit different from that to which the receiver is connected.
- Consult the dealer or an experienced radio/TV technician for help.

For indoor use only.

To access the system legal information:

1. Touch the Inview display to go to the Main screen and tap the Administration  icon on the main screen.

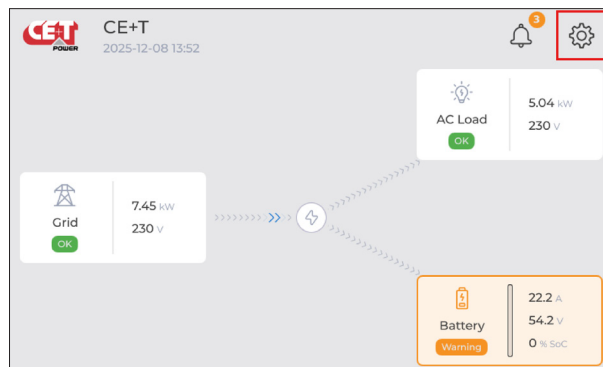

2. Tap the System Information option on the screen.

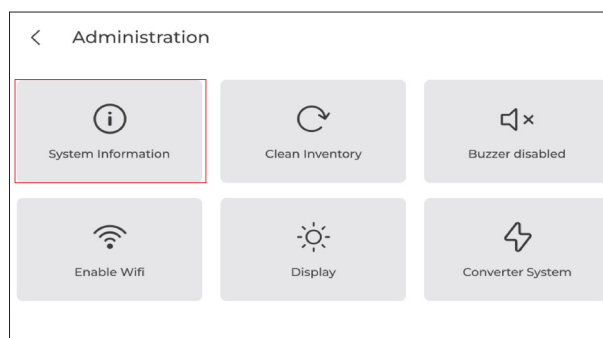

3. Touch the Legal Information option on the screen.

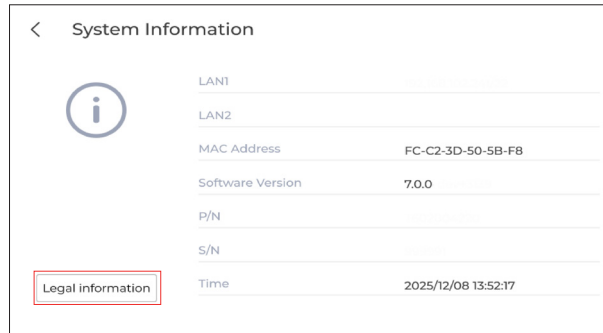

4. This screen show the legal information/Disclaimer.

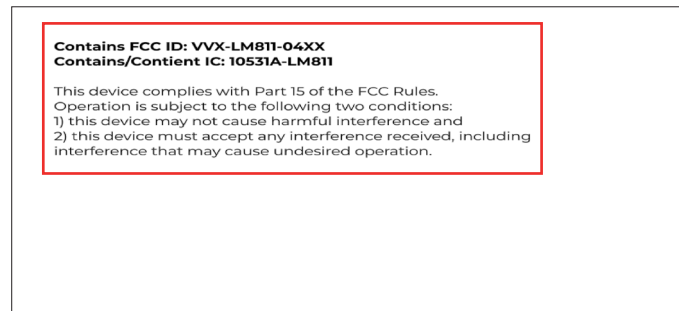

#### FCC RF Radiation Exposure

1. This Transmitter must not be co-located or operating in conjunction with any other antenna or transmitter.
2. For portable operation, this device has been tested and meets FCC RF exposure guidelines. When used with an accessory that contains metal may not ensure compliance with FCC RF exposure guidelines.

You are cautioned that changes or modifications not expressly approved by the part responsible for compliance could void the user's authority to operate the equipment.

#### Canada:

For indoor use only - Pour usage intérieur seulement

This device contains licence-exempt transmitter(s)/receiver(s) that comply with Innovation, Science and Economic Development Canada's licence-exempt RSS(s). Operation is subject to the following two conditions:

1. This device may not cause interference, and
2. This device must accept any interference, including interference that may cause undesired operation of the device.

L'émetteur/récepteur exempt de licence contenu dans le présent appareil est conforme aux CNR d'Innovation, Sciences et Développement économique Canada applicables aux appareils radio exempts de licence. L'exploitation est autorisée aux deux conditions suivantes :

1. l'appareil ne doit pas produire de brouillage, et
2. l'utilisateur de l'appareil doit accepter tout brouillage radioélectrique subi, même si le brouillage est susceptible d'en compromettre le fonctionnement.

**Caution:** Exposure to Radio Frequency Radiation

1. To comply with the Canadian RF exposure compliance requirements, this device and its antenna must not be co-located or operating in conjunction with any other antenna or transmitter.
2. For portable operation, this device has been tested and meets RF exposure guidelines when used with an accessory that contains no metal. Use of other accessories may not ensure compliance with RF exposure guidelines.

**Attention:** exposition au rayonnement radiofréquence

Pour se conformer aux exigences de conformité RF canadienne l'exposition, cet appareil et son antenne ne doivent pas être co-localisés ou fonctionnant en conjonction avec une autre antenne ou transmetteur.

Pour portable utilisation, cet appareil a été testé et respecte les directives sur l'exposition aux RF lorsqu'il est utilisé avec un accessoire sans métal. L'utilisation d'autres accessoires peut ne pas garantir la conformité aux directives d'exposition aux RF.

To comply with the Canadian RF exposure compliance requirements, this device and its antenna must not be co-located or operating in conjunction with any other antenna or transmitter.

For portable operation, this device has been tested and meets RF exposure guidelines when used with an accessory that contains no metal. Use of other accessories may not ensure compliance with RF exposure guidelines.

