



Leading Conversion Technology for Power Resilience

SIERRA 10 - 48/120

User Manual

THE NEW GENERATION OF POWER CONVERTERS

- **DUAL AC AND DC OUTPUT CONVERTER**
Commercial Power as default source
- **AC AND DC BACKUP IN A DC ENVIRONMENT**
Leverage your existing DC infrastructure
- **ONE STOP SHOP**
Wide output power range
- **HARSHEST AC INPUT CONDITIONS**
Without compromising the quality of the AC output

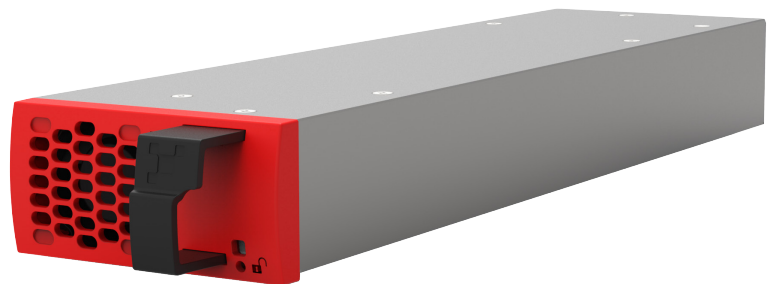

Copyright © 2026. Construction electroniques & telecommunications S.A.
All rights reserved. The contents in document are subject to change without notice.
The products presented are protected by several international patents and trademarks.
Address: CE+T S.a, Rue du Charbonnage 12, B 4020 Wandre, Belgium
www.cet-power.com - info@cet-power.com

Version 1.6

Contact us:  www.cet-power.com

Follow us on social media:



Table of Contents

1.	CE+T Power at a glance.....	5
2.	Abbreviations.....	6
3.	Warranty and Safety Conditions	7
3.1	Disclaimer	7
3.2	Technical care	7
3.3	Installation	8
3.3.1	Handling.....	8
3.3.2	Surge and transients	9
3.3.3	Other.....	9
3.4	Maintenance	9
3.5	Replacement and Dismantling.....	9
4.	ECl Technology.....	10
4.1	AC-AC mode.....	11
4.2	DC-AC mode	11
5.	Building Blocks	12
5.1	Sierra 10 - 48/120	12
5.1.1	Specifications.....	12
5.1.2	Converter - LED Indications	14
5.2	Sub-rack.....	14
6.	Monitoring device - Inview S, X and GW	14
7.	System Installation.....	16
7.1	Transformer and Generator Sizing	16
7.2	Sierra 10 Shelf Mounting kit - Single part.....	17
7.3	Cable Routing and Fixation	18
7.3.1	Grounding	18
7.4	Electrical Installation for Sierra 10 shelf.....	19
7.4.1	Pre requisites	19
7.4.2	Terminations	20
7.4.3	Single Phase Configuration - 120 Vac.....	21
7.4.4	Split Phase or Single Phase Configuration - 240 Vac.....	22
7.4.5	Three Phase Configuration - 208 Vac.....	23
7.4.6	AC Input and Output Connections	24
7.4.7	DC Connection	25
7.4.8	Hardware Connections	25
7.4.9	Signalling	26
8.	Replacement procedures	28
8.1	Module - Sierra 10	28
8.1.1	Removal.....	28
8.1.2	Inserting.....	28

8.2	Controller - Inview Slot	29
8.2.1	Removal	29
8.2.2	Inserting	29
9.	Manual By-Pass (Optional)	30
9.1	Pre-requisites	30
9.2	MBP Auxiliary connection	30
9.3	Manual By-Pass Operation	31
9.3.1	Normal to By-pass (Engage MBP)	31
9.3.2	By-pass to Normal (Disengage MBP)	31
10.	Finishing	32
11.	Commissioning	33
11.1	Check list	34
12.	Trouble Shooting and Defective Situations Fixing	35
12.1	Trouble Shooting	35
12.2	Defective Modules	35
13.	Maintenance	36
13.1	Access Inview with Laptop	36
13.2	Manual check	36
13.3	Optional	36
14.	Service	37
15.	Appendix	38
15.1	Sierra 10 - 48/120 - Dimensions	38
15.1.1	Module	38
15.1.2	Shelf	38
15.2	System Connections and Wiring diagrams	39
15.2.1	Single phase (L-N)	39
15.2.2	Single phase (L-N) - REG	40
15.2.3	Single shelf - Split phase (L1-L2-N)	41
15.2.4	Single shelf - Split phase (L1-L2-N) - REG	42
15.2.5	Two shelves - Split phase (L1-L2-N)	43
15.2.6	Two shelves - Split phase (L1-L2-N) - REG	44
15.2.7	Three phase (L1-L2-L3-N)	45
15.2.8	Three phase (L1-L2-L3-N) - REG	46
15.3	Modules - Parameter List	47

Release Note:

Version	Release date (DD/MM/YYYY)	Modified page number	Modifications
1.0	07/02/2022	-	First release of the manual
1.1	15/09/2022	-	Updated the shelf connections
1.2	16/10/2024	15 & 27	Updated the Inview and DC breaker details
		17 & 30	Added shelf mounting kit and MBP procedure
1.3	12/03/2025	25	Serial numbers are updated
1.4	15/09/2025	33	Updated section "11. Commissioning"
1.5	12/12/2025	13	Added low voltage disconnect (LVD) information
1.6	03/02/2026	35	Updated section "12.1 Trouble Shooting"

1. CE+T Power at a glance

CE+T Power is your trusted partner in **advanced power solutions** engineered to meet the demands of modern and dynamic industrial applications. With over 60 years of experience in power conversion technology, CE+T Power nurtures the industry with **innovative solutions designed for critical power backup and energy management**.

Our complete range of power solutions includes **modular inverters** (DC to AC), **UPS** (securing AC loads with batteries), and **multi-directional converters** (inverter, rectifier, and UPS all-in-one). Coupled with our state-of-the-art **monitoring solution**, you have a real energy blender to connect multiple sources of energy seamlessly!

Whether you require **robust backup power solutions**, **energy management solutions**, or a **combination of both**, CE+T Power delivers tailored solutions to meet your specific needs. Our products are **designed with integration in mind**, ensuring **seamless compatibility with other components of your system**. CE+T Power is committed to providing you with the expertise and resources needed to maximize the performance of your power systems.

Thank you for choosing CE+T Power as your partner in advanced power management. Let's power the future together.

2. Abbreviations

AC	Alternating current
CB	Circuit Breaker
DC	Direct current
DHCP	Dynamic Host Configuration Protocol
DSP	Digital Signal Processor
ECI	Enhanced Conversion Innovation
EMBS	External Maintenance Bypass Switch
EPC	Enhanced Power Conversion
ESD	Electro Static Discharge
ETH	Ethernet
G	Ground / Grounding
HTTP	HyperText Transfer Protocol
HTTPS	Secure HyperText Transfer Protocol
LAN	Local Access Network
MBB	Measure Box Battery
MBP	Manual By-pass
MCB	Miniature Circuit Breaker
MCCB	Molded Case Circuit Breaker
MET	Main Earth Terminal
MIB	Management Information Base
N	Neutral
NTP	Network Time Protocol
NUA	Non-Urgent Alarm
PCB	Printed Circuit Board
PE	Protective Earth (also called Main Protective Conductor)
PEK	Power Extension Kit
PPE	Personal Protective Equipment
PWR	Power
REG	Regular
SNMP	Simple Network Management Protocol
TCP/IP	Transmission Control Protocol/Internet Protocol
TRS	True Redundant Structure
UA	Urgent Alarm
USB	Universal Serial Bus

3. Warranty and Safety Conditions*

WARNING:

The electronics in the power supply system are designed for an indoor, clean environment.

When installed in a dusty and/or corrosive environment, outdoor or indoor, it is important to:

- Install an appropriate filter on the enclosure door, or on the room's air conditioning system. Installation of filters may result in derating of module.
- Keep the enclosure door closed during operation.
- Replace the filters on a regular basis.

Important Safety Instructions and Save These Instructions.

3.1 Disclaimer

- The manufacturer declines all responsibilities if equipment is not installed, used or operated according to the instructions herein by skilled technicians according to local regulations.
- Warranty does not apply if the product is not installed, used or handled according to the instructions in the manual. Manufacturer may waive warranty if the system is not installed and commissioned by factory trained technician.
- This equipment is shipped with a SHOCKWATCH monitor. If the SHOCKWATCH shows that the equipment was exposed to excessive force the warranty will be void.

3.2 Technical care

- This electric equipment can only be repaired or maintained by a "qualified employee" with adequate training. Even personnel who are in charge of simple repairs or maintenance are required to have knowledge or experience related to electrical maintenance.
- Please follow the procedures contained in this Manual, and note all the "DANGER", "WARNING" AND "NOTICE" marks contained in this Manual. Warning labels must not be removed.
- Qualified employees are trained to recognize and avoid any dangers that might be present when working on or near exposed electrical parts.
- Qualified employees know how to lock out and tag out machines so the machines will not accidentally be turned on and injure employees working on them.
- Qualified employees are trained in OSHA and NFPA safety related work practices, and NFPA 70E Arc Flash Protection and PPE requirements.
- All operators are to be trained to perform the emergency shut-down procedure.
- Never wear metallic objects such as rings, watches, or bracelets during installation, service and maintenance of the product.
- Insulated tools must be used at all times when working with live systems.
- When handling the system/units pay attention to sharp edges.
- This product is suitable for use in a computer room.

* These instructions are valid for most CE+T Products/Systems. Some points might however not be valid for the product described in this manual.

3.3 Installation

- This product is intended to be installed only in restricted access areas as defined by UL60950 and in accordance with the National Electric Code, ANSI/NFPA 70, or equivalent agencies and in a temperature-regulated, indoor area that is relatively free of conductive contaminants.
- The Converter System may contain output over current protection in the form of circuit breakers. In addition to these circuit breakers, the user must observe the recommended upstream and downstream circuit breaker requirements as defined in this manual.
- Please use extreme caution when accessing circuits that may be at hazardous voltages or energy levels.
- The modular converter rack is a dual input power supply. The complete system shall be wired in a way that both input and output leads can be de-energized when necessary.
- The systems that have no AC input wired and connected can be seen as independent power sources. To comply with local and international safety standards N (input) and PE shall be bonded. The bonded connection between N (input) and PE must be removed once the AC input is connected.
- AC and DC circuits shall be terminated with no voltage/power applied (de-energized).
- The safety standard IEC/EN62040-1-1 requires that, in the event of an output short circuit, the inverter must disconnect in 5 seconds maximum. The parameter can be adjusted on Inview; however, if the parameter is set at a value > 5 seconds, an external protection must be provided so that the short circuit protection operates within 5 seconds. Default setting is 60 seconds.
- The system is designed for installation within an IP20 or IP21 environment. When installed in a dusty or humid environment, appropriate measures (air filtering) must be taken.
- Environment Conditions:
 - Storage Conditions: -40 to 70°C
 - Relative Humidity: 95%, non-condensing
 - Altitude above sea without de-rating: Less than 1500 m
Greater than 1500 m – de-rating at 0.8% per 100 m
Should not be installed above 4000 m
- All illustrations in the manual are for general reference, refer to the technical drawing which is received along with the system for exact information.

3.3.1 Handling

- The cabinet shall not be lifted using lifting eyes.
- Remove weight from the cabinet by unplugging the inverters. Mark inverters clearly with shelf and position for correct rebuild. This is especially important in dual or three phase configurations.
- Empty converter positions must not be left open. Replace with module or dummy cover.

3.3.2 Surge and transients

The mains (AC) supply of the modular inverter system shall be equipped with Lightning surge suppression and Transient voltage surge suppression suitable for the application. Follow manufacturer's recommendation for installation. Selecting a device with an alarm relay for function failure is advised.

All sites are considered to have a working lightning surge suppression device in service and installed close enough to ensure effective protection in accordance with best industry practice.

- Indoor sites Min Class II.
- Outdoor sites Min Class I + Class II or combined Class I+II. The modular inverter system/rack can reach hazardous leakage currents. Earthing must be carried out prior to energizing the system. Earthing shall be made according to local regulations.

Note: Choosing and installing surge arrestors must obey to precise technical rules. Distance to equipment to protect, cable gage and cable routing have significant influence on proper device service.

Some areas are more susceptible to be hit by electrical strikes, especially when altitude increases. Good earthing is also crucial for surge arrestors to work properly. CE+T declines any liability in regard to damaged caused to equipment not correctly or not sufficiently protected.

3.3.3 Other

- Insulation test (Hi-Pot) must not be performed without instructions from the manufacturer. Irreparable damage may occur.

3.4 Maintenance

- The converter system/rack can reach hazardous leakage currents. Earthing must be carried out prior to energizing the system. Earthing shall be made according to local regulations.
- Prior to any work conducted on a system/unit make sure that AC input voltage and DC input voltage are disconnected.
- **CAUTION** – Risk of electric shock. Converter modules and shelves contain capacitors for filtering and energy storage. Prior to accessing the system/modules after power down, wait at least 5 minutes to allow capacitors to discharge.
- **CAUTION** – During system operation, the system and module surfaces will be hot. Do not touch, and contact may cause severe burns. So, please turn off the power and allow it to cool before accessing. 
- Some components and terminals carry high voltage during operation. Contact may result in fatal injury.

3.5 Replacement and Dismantling

- ESD Strap must be worn when handling PCB's and open units. The converter system/rack is not supplied with internal disconnect devices on input nor output.
- CE+T cannot be held responsible for disposal of the Inverter system and therefore the customer must segregate and dispose of the materials which are potentially harmful to the environment, in accordance with the local regulations in force in the country of installation.
- If the equipment is dismantled, to dispose of its component products, you must comply with the local regulations in force in the country of destination and in any case avoid causing any kind of pollution.

Note: To download the latest documents, please visit our website www.cet-power.com and to download latest software visit our website my.cet-power.com.

4. ECI Technology¹

A Sierra module is a triple port converter built with ECI technology. This module delivers pure sinusoidal output and ripple free DC output from AC mains or battery.

The below block diagram gives an explicit description of the topology and its operation.

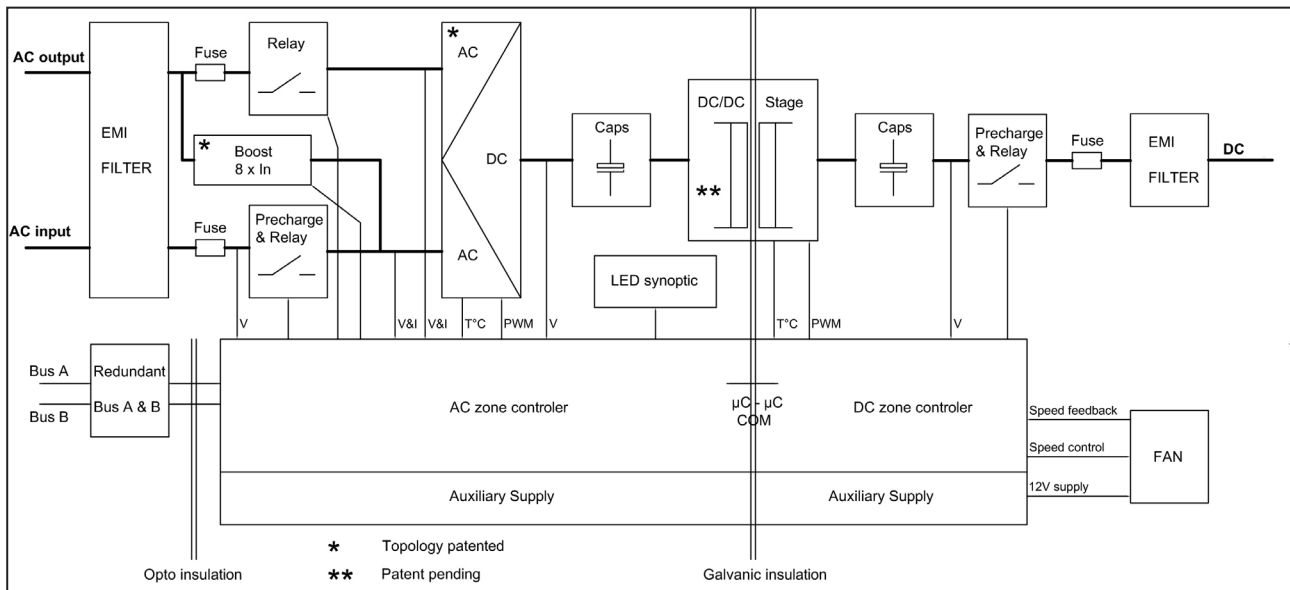

ECI technology has AC to DC, DC to AC, and DC to DC converters to provide constant and disturbance-free output power regardless of the input source.

The power flows either from AC or DC source under the control of the DSP controller. Thanks to the module's internal energy buffering, transferring the load between two input sources is achieved in 0 ms.

In the case of a short circuit at the AC output, the converter will provide 4 x In during 20 ms to force output MCB to trip. Breaker selectivity shall be adapted according to the power available.

Sierra module works on True Redundant Structure (TRS) that features decentralized, independent logic, and redundant communication bus.

Each Sierra module has three levels of protection, and it will help to isolate from other modules in case of any fault in the corresponding module. Due to this functionality in each module, it provides no single point of failure in modular systems.

The Sierra modular systems provide quality output power with higher efficiency.

¹ Information and data given in this chapter is intended to serve as an overview of the ECI Technology. Detailed features and parameters for each individual module type in the range may differ and should be referred to in the dedicated data sheet.

4.1 AC-AC mode

In AC-AC mode, the AC Mains is the primary source and DC source works as a backup. When AC mains is present, the Sierra module takes energy from the AC source and feed to:

- AC Load via a double conversion to provide a pure sine wave.
- DC load and also charges the battery with a regulated DC.

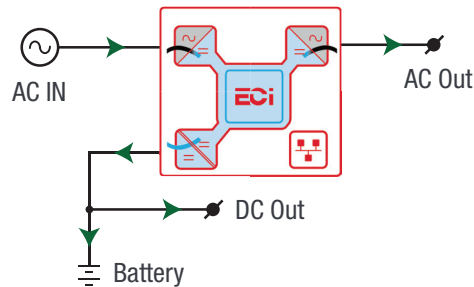

The total output power of a module can be shared between the AC load, DC load and charging power based upon the requirement.

If the AC source is not present, the module seamlessly switches to DC source without impacting the critical loads and resumes to EPC mode once AC source returns. The transfer time between AC to DC and DC to AC is 0 ms.

The EPC mode provides a higher efficiency of $\geq 96\%$ without compromising the purity of the output sine wave.

4.2 DC-AC mode

In DC-AC mode, module operates in DC source and feed to:

- AC Load via a double conversion to provide a pure sine wave.
- DC load directly.
- Measure Box Battery (MBB) is used for DC power calculation.

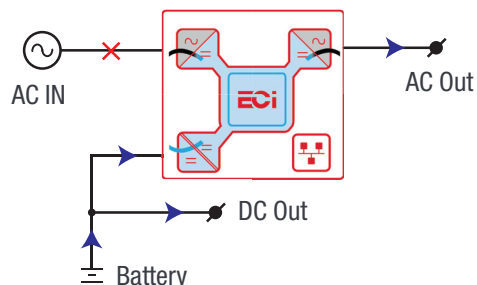

5. Building Blocks

5.1 Sierra 10 - 48/120

Telecom / Datacom:	Input	48 Vdc 120 Vac, 50/60 Hz
	Output	120 Vac and 48 Vdc
	Power	1000 VA / 800 W



- The Sierra converter is a triple port converter.
- Each converter can supply 800 W on any DC, AC or combination of both AC and DC output ports. AC output load is the highest priority. Even if AC / DC output is fully loaded (800 W), still 200 W is available for AC / DC output.
- Hot swappable and hot pluggable.
- The front LED's indicate the converter status and output power.
- The module is equipped with soft start.
- 325 mm (D) x 87 mm (W) x 1U (H).
- 1.5 Kg.

5.1.1 Specifications

Model	Sierra 10 - 48/120
Part Number: Module / Shelf	T711330201 / T714330000
Cooling / Audible noise	Fan forced cooling / <65db @1meter
MTBF	200 000 hrs at 30°C, @80% load (MIL-217-F)
Dielectric strength DC/AC	4300 Vdc
RoHS	Compliant
Operating T° / Relative Humidity (RH) non-condensing	Tested according ETS300-019-2-3 Class 3.1 -20°C to 65°C, power de-rating from 40°C to 65°C / Max RH 95% for 96 hours per year
Storage T° / Relative Humidity (RH) non-condensing	Tested according ETS300-019-2-1 Class 1.2 -40°C to 70°C / Max RH 95% for 96 hours per year
Public transport T°/Relative Humidity (RH) non-condensing	Tested according ETS300-019-2-2 Class 3.1 -40°C to 70°C / Max RH 95% for 96 hours per year
Material (casing)	Zinc coated steel
AC Input Data	
Nominal voltage (AC) / Current	120 Vac / 9.2 A
Voltage range (AC)	95 - 140 Vac
Brownout	< 108 Vac linear decreasing
Power factor / THD	> 99% / < 3%
Frequency range (selectable) / synchronization range	60 Hz (range 57 – 63 Hz) / 50 Hz (range 47 – 53 Hz)

DC Input Data	
DC voltage: Nominal / range	48 Vdc / (40-60V)
Nominal current (at 48 Vdc and 800 W output)	18.5 A
Maximum input current (for 15 second) / voltage ripple	22.5 A / < 10 mV RMS
Internal Low Voltage Disconnect (LVD)	Starts @ 44.4 V / Stops @ 43.2 V
AC Output Data	
Efficiency AC to AC (EPC) / DC to AC / AC to DC	94% / >92% / >92%
Nominal voltage AC (Adjustable)	120 V (100 - 130 Vac)
Frequency / frequency accuracy	50 or 60 Hz / 0.03%
Nominal Output power (VA) / (W)	1000 VA / 800 W (at 800 W AC load, still 200 W are available for 48V DC load)
Short time overload capacity	125% (15 seconds)
Admissible load power factor	Full power rating from 0 inductive to 0 capacitive
Total harmonic distortion (resistive load)	< 3%
Load impact recovery time (10% - 90%)	≤ 0.4 ms
Nominal current	8.3 A @ 120 Vac
Crest factor at nominal power	3 : 1 for load P.F. ≤ 0.7
Short circuit clear up capacity 0-20 ms	34 A
Short circuit current after 20 ms	16.5 A for 15 sec, 12.5 A from 15 to 60 sec , after 60 sec - manual reset is required
AC output voltage stability	±1% from 10% to 100% load
DC Output Data	
Nominal voltage (range)	53.5 Vdc (44 - 60 Vdc)
Maximum power	800 W (at 800 W DC load, still 200 W are available for AC load)
Maximum current at 48 Vdc	16.7 A
Reverse polarity protection	YES
Efficiency AC to DC	> 92%
Max. Voltage interruption / total transient voltage duration (max)	0 sec / 0 sec
Signalling & Supervision	
Display	Synoptic LED
Supervision / Part number	Inview ranges: Inview Slot - T602004110, Inview S - T602004100 and Inview GW - T602004000
Remote on / off	On rear terminal of the shelf through Inview
Battery Monitoring / Part number	MBB (Measure Box Battery) - 6 dry contacts and 8 digital Inputs / T602006000
Safety & EMC	
Safety	UL1778
EMC	EN 61000-4-2 / EN 61000-4-3 / EN 61000-4-4 / EN 61000-4-5 / EN 61000-4-6 / EN 61000-4-8 ETSI EN 300386 v1.9.1 / FCCpart 15 class A

5.1.2 Converter - LED Indications

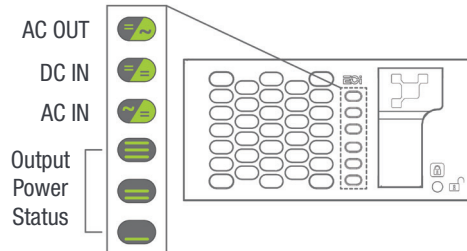

Converter Status LED	Description	Remedial action
OFF	No input power or forced stop	Check environment
Permanent green	Operation	
Blinking green	Converter OK but working conditions are not fulfilled to operate properly	
Blinking green/orange alternatively	Recovery mode	
Permanent orange	Starting mode	
Blinking orange	Modules cannot start	Check Inview
Blinking red	Recoverable fault	
Permanent red	Non recoverable fault	Send module back for repair

Output Power (redundancy not counted)						
<5%	5% to 40%	40 to 80%	80 to 95%	100%	100% = overload	Output Power (redundancy not counted)
×	×	×	≡	≡	≡	Status output power LED
×	×	≡	≡	≡	≡	
—	—	—	×	—	—	
1B	1P	2P	2P	3P	3B	Behaviour (B - Blinking P - Permanent)

5.2 Sub-rack

- The shelf is designed with both Single-phase and Split-phase
- The Sierra shelf shall be integrated in min 600 mm deep cabinets, 1Inch/ETSI mounting
- The shelf houses max four modules and one Inview Slot
- The extension shelf houses max five modules
- Each shelf has common DC Input, AC Input and AC Output
- It is featured with rear protection cover (IP 20)
- Max 5 kVA / 4 kW per shelf
- Dimension: 497 mm (D) x 19” (W) x 1U (H)
- Weight: 2.5 Kg (without modules)



Sierra 10 - Subrack system

6. Monitoring device - Inview S, X and GW

Sierra 10 modules can be monitored through Inview Slot, S, X or Inview GW. For more details about these monitoring devices and the hardware connections, refer to the Inview and Inview GW user manuals.

Inview Slot, S and X - <https://datasheet.cet-power.com/CET - Monitoring - User Manual - Inview - EN.pdf>

Inview GW - <https://datasheet.cet-power.com/CET - Monitoring - User Manual - Inview GW - EN.pdf>



Inview GW



Inview Slot



Inview S



Inview X

7. System Installation

Input and output protections

When installing Sierra 10 converter systems, UL489 listed AC upstream (input) and downstream (output) circuit breakers are required. Refer section 7.4.6, page 24.

AC Input and Output

- Branch circuit protection breaker should be provided in upstream switchgear regardless of any protective device already installed at the input of the Sierra 10 system.
- An appropriate branch protection should be provided between the Sierra 10 System and the load.

DC

- An appropriate DC over current protection device should be installed at both Input and Output.

Output distribution should be structured to guarantee tripping segregation. Contact the manufacturer for recommendations and calculation methodology.

- Refer to section 7.4.6, page 24 for sizing protections and connecting cables. All cables must be copper rated for min 90°C (194°F).
- All cables must be C-UL-US or CSA Listed cables.
- All cables lugs must be C-UL-US or CSA listed. They must be sized according to the rated current of the converter system and to the customer terminal connection.
- Wire all positions for future expansion.
- Input AC / Output AC / Input DC / Signal cables shall be separated.
- Cable crossings shall be done in 90 deg angles.
- Empty converter positions shall be covered with blank module.
- Sierra 10 system is designed for temperature controlled (40°C / 104°F max) and clean environments. The presence of airborne particles such as urban dust, sand, metallic dust, and corrosive vapours is forbidden. Install only in a relatively free of conductive contaminants environment.

7.1 Transformer and Generator Sizing

The converter is capable of operating at 125% of rated capacity for 15 seconds.

- Transformers supplying AC to the converter should be sized at a minimum of 1.25 times the kVA rating of the converter to meet this requirement.
- Generators supplying emergency AC to the building and to the converter should be sized at a minimum of two times the kVA rating of the converter.
- If the output waveform of the Generator/Transformer can be guaranteed even in Overload conditions 125% for 15 seconds, then the Generator/ Transformer Sizing could be same as SYS capacity.

7.2 Sierra 10 Shelf Mounting kit - Single part

Sierra 10 shelf mounting kit - Single part is designed to at front side of the cabinet. The part number is **T602005000** and has the following accessories in the kit.

S.No	Parts Description	Quantity		
		Single shelf	Two-shelves pack	Three-shelves pack
1	Sierra 10 Shelf Support - RH - PD605_047	1	1	1
2	Sierra 10 Shelf Support - LH - PD605_048	1	1	1
3	M6 x 16mm Philip head screw	10	10	14
4	M6 x 16mm CSK head screw	6	6	6
5	M6 cage nut	14	14	18
6	M6 Flat washer	6	6	6
7	Sierra 10 Shelf Clamp	NA	2 (PD605_052)	2 (PD605_046/1)
8	M3 x 4mm CSK head screw	NA	20	28

Perform the following steps to install the shelf in the cabinet:

1. Place the left and right shelf support in the cabinet and fix it with **4 x M6 CSK head screws** and cage nuts. *(Note: Fix all the required cage nuts before placing the support and shelf.)*
2. Place the shelf on the support and fix it in the cabinet with **8 x M6 Philip head screws**, washers and cage nuts.

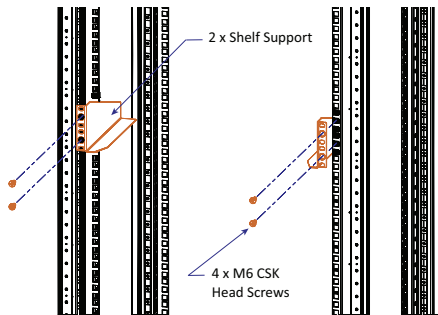

Fix the shelf support

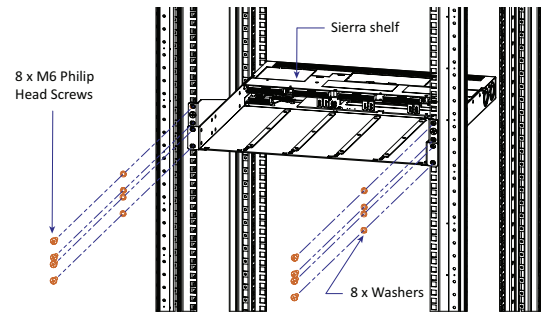

Place the shelf on the support and fix it

In two- and three-shelf packs, assemble the shelves separately with respective clamps, place the pack on the support, and fix it in the cabinet. **Note:** While assembling the pack, fix the bottom shelf first with clamps, then the middle and top shelf.

- Installing two-shelves pack

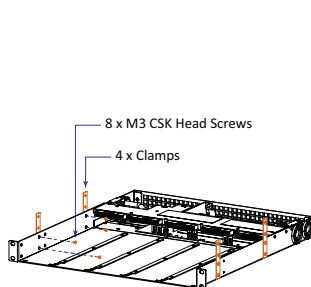

Fix the clamps in the bottom shelf

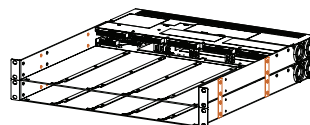

Place the top shelf and fix it

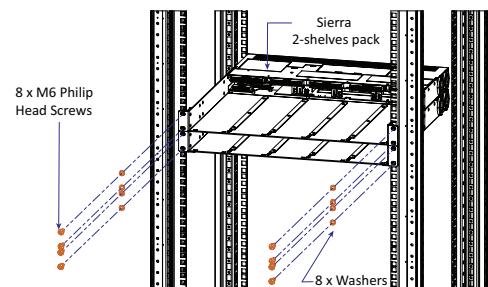

Place the pack on the support and fix it

- Installing three-shelves pack

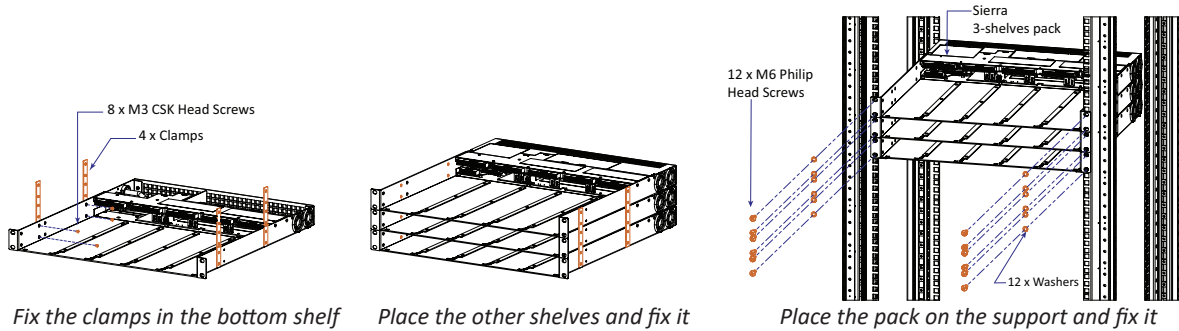

7.3 Cable Routing and Fixation

Terminations are present at rear side of the shelf and it is protected with IP 20 metal cover.

Perform the following steps to connect power and signal cables:

1. Remove the rear protection cover by unscrewing four screws (Two at the rear and one on both sides).
2. Break the required Knock-outs and insert the grommets (1 x large, 2 x small, and 1-meter strip) for cable protection, and it is shipped along with the shelf. **(Warning: Take special attention while breaking Knock-outs to avoid damaging the connectors, terminals and PCB in the shelf.)**
 - AC IN and OUT cables entry – Right end of the shelf (2 - Knock-outs)
 - DC cables entry – Left end of the shelf (2 - Knock-outs)
 - Knock-outs are also available at top and bottom of the protection cover.

Note: Refer to section 15.1, page 38, to know more about Knock-out dimensions.

3. Connect the power and signal cables with supplied screws, refer section 7.4.2, page 20 for terminals position.
4. Close the rear protection cover and tighten with four screws.

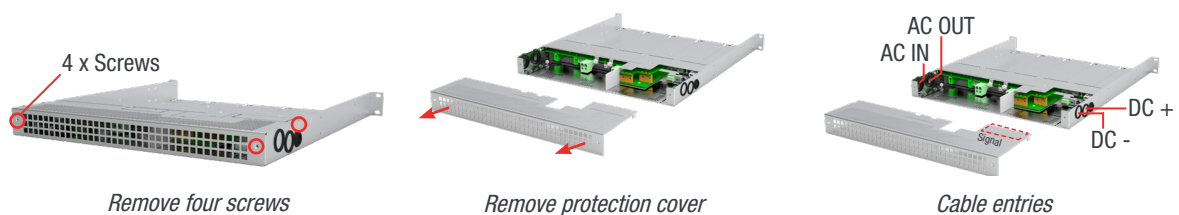

7.3.1 Grounding

“PE Chassis Ground” 

PE Chassis ground should be wired to MET (Main Earth Terminal) or distributed earth bar connected to MET, according to local regulations. The wire size should be 4 AWG.

Warning: The converter module and shelves contain filters designed to protect against voltage surges and other disruptions. These filters have capacitors between L, N and earth (PE), which adds to the overall capacitance of the wiring system and the overall level of leakage current. Operation in the IT network may conduct to a high leakage current that needs to be monitored and controlled.

The PE connection is on the left side of the shelf. In two and three shelves packs, a single PE connection is enough, and it can be connected to any one of the shelves.

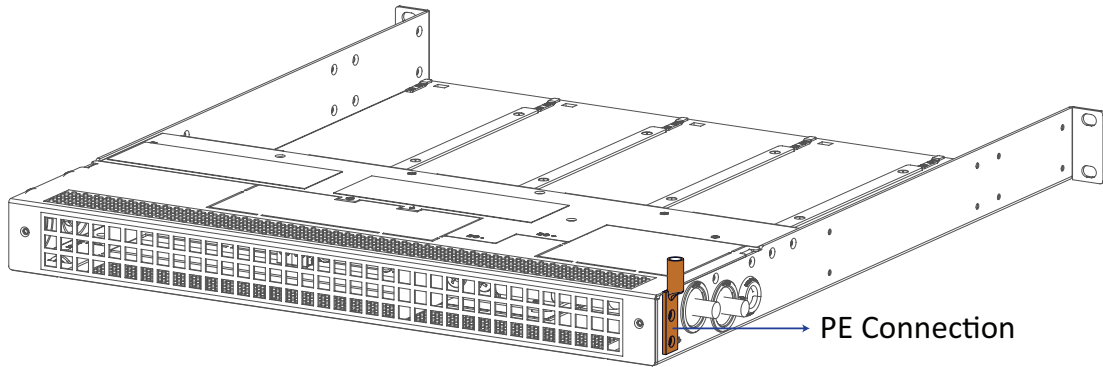

It is mandatory to use only C-UL-US or CSA listed Right angle ring terminal Cable Lugs (Panduit). Fix the lug with 1/4-20 inch **Nut** with torque 5.7 to 8.3 ft-lb.

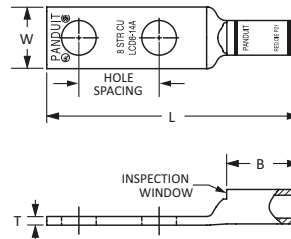

Part Number	Copper Conductor Size	Stud Hole Size (In.)	Stud Hole Spacing (In.)	Figure Dimensions (In.)				Wire Strip Length (In.)
				W	B	T	L	
Panduit LCD4-14A-L	#4 – #3 AWG STR, #2 AWG SOL	1/4	0.63	0.55	0.81	0.09	2.26	7/8

Note: Only listed two-hole compression type connectors shall be used in Making connections to flat surfaces such as Bus Bars, Frames, Racks, or Cabinets.

7.4 Electrical Installation for Sierra 10 shelf

7.4.1 Pre requisites

- The sub-rack have markings for all terminations.
- All cables shall be rated at Min 90 deg C.
- Electrical terminations shall be tightened with 5 Nm.
- All connection screws are M5 x 12 mm.
- DC Input - Common (per shelf), check DC polarity.
- AC Input / AC output - Common (per shelf), check AC phase angle.
- Wire all positions in the sub-rack for future expansion.

7.4.2 Terminations

7.4.2.1 EPC Version

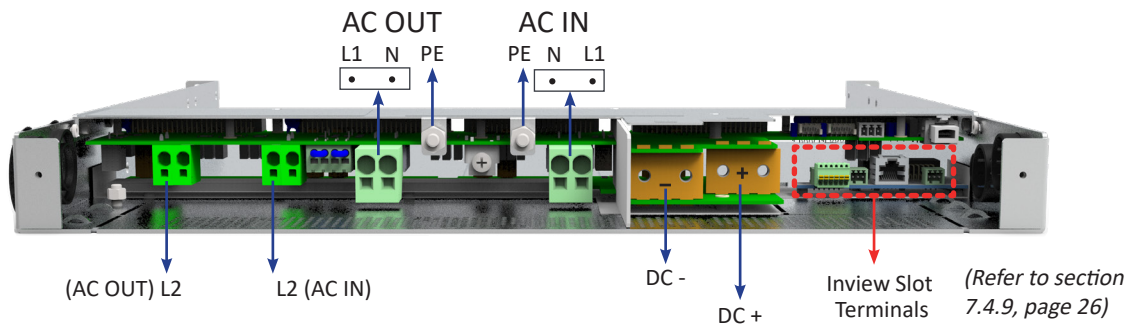

Sierra 10 - 48/120 - Shelf Rear Details

7.4.2.2 REG Version (No AC In)

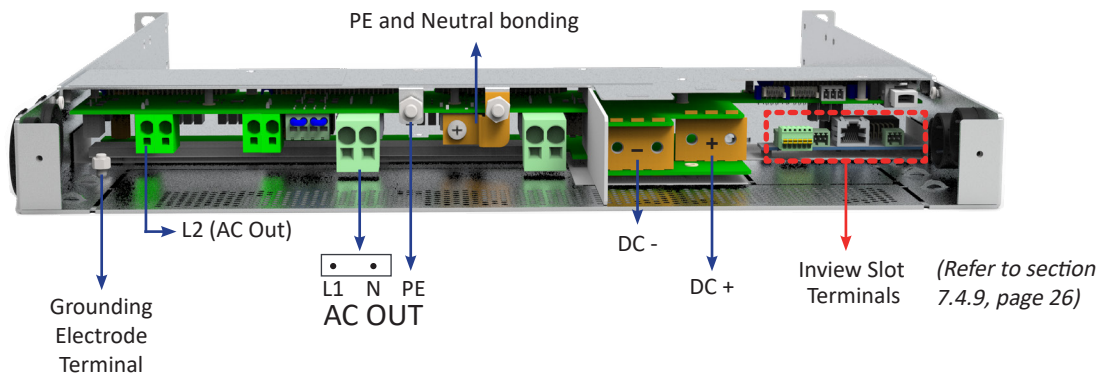

Sierra 10 - 48/120 - Shelf Rear Details - REG (No AC Input)

Note: In REG version, a copper plate is placed between PE and Neutral. Also, ground should be connected to Grounding electrode terminal using 10-24 inch nut of torque 3.2 to 4.8 ft-lb.

7.4.3 Single Phase Configuration - 120 Vac

Each shelf is designed with both Single-phase and Split-phase. If it is a single-phase, place the two jumpers (J1 & J2) and connect AC cables at AC IN 1 and AC OUT 1 terminals. A single-phase system is 120 Vac from L to N.

Input and output are the same, consisting of 2 wires + (PE) Ground.

Note: The jumper cable should be a minimum of 12 AWG.

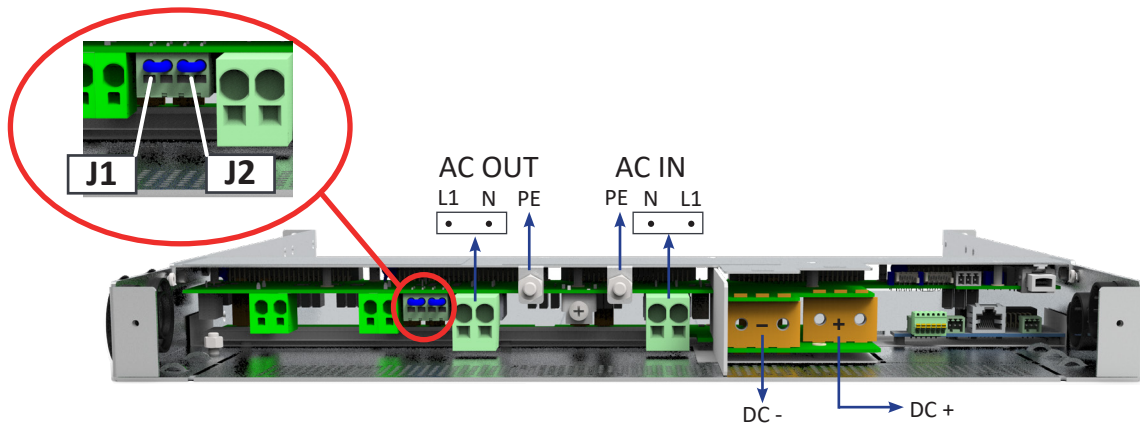

7.4.3.1 Single Phase Configurations with Inview Slot, S or X

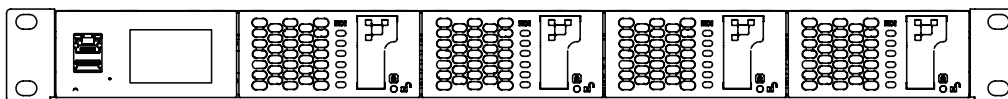

Single phase with Inview Slot - 4 kVA

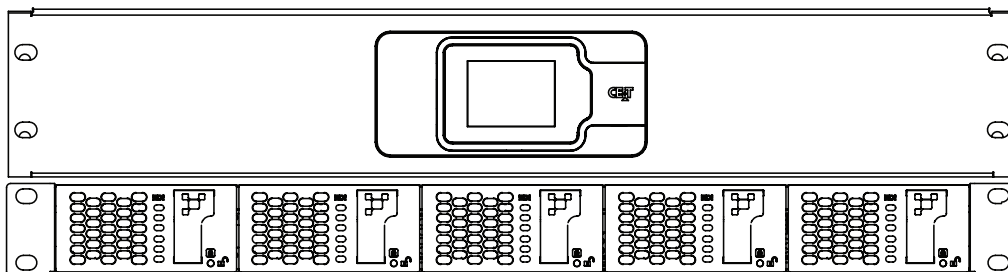

Single phase with Inview S - 5 KVA

7.4.4 Split Phase or Single Phase Configuration - 240 Vac

A split-phase system is 120 Vac from L to N, and 240 Vac from L1 to L2 and L1 and L2 are phase-shifted by 180 degrees.

A shelf can be configured as Split-phase. To do it, **remove the two jumpers** and connect AC cables in the terminals as per the below image.

Note: If the Split-phase is designed with two shelves, the **Jumpers (J1 and J2)** should be present on both shelves. For connection details, refer to sections 15.2.5, page 43 and 15.2.6, page 44. In each phase, the number of modules should be equal.

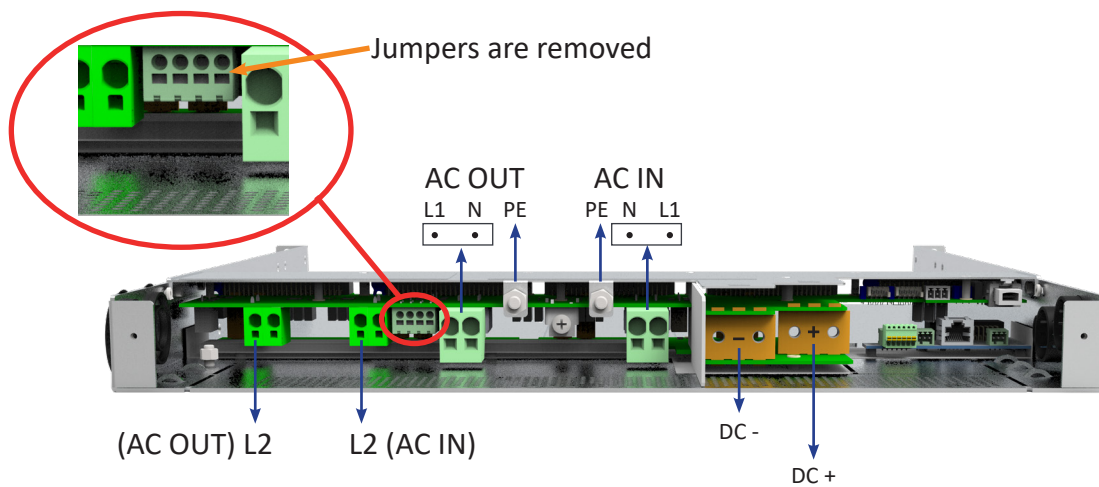

7.4.4.1 Split Phase Configurations with Inview Slot, S or X

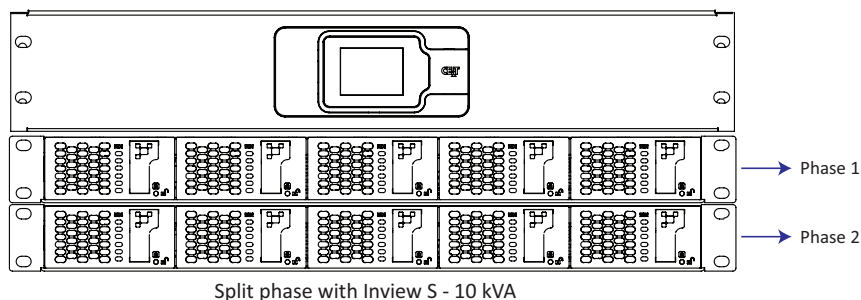
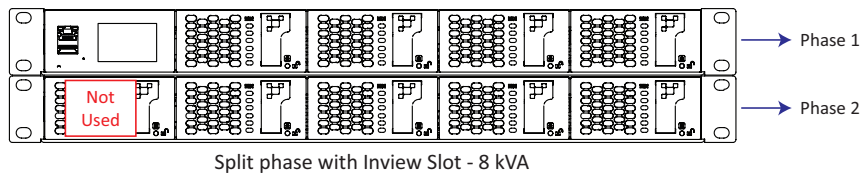
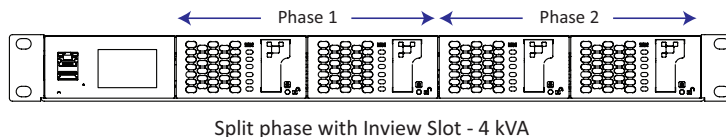

7.4.5 Three Phase Configuration - 208 Vac

Three-phase systems are 120 Vac L to N and 208 Vac from L1 to L2, L1 to L3, L2 to L3. Input and output are made upon four wires + (PE) Ground, “Y” or “Star” connection. All phases are phase shifted by 120 degrees one to the other.

Three-phase can be configured with three shelves as per in the below image. **CET Bus** and **Neutral** cables must be paralleled if it is multiple shelves.

Note: In each phase, the number of modules should be equal.

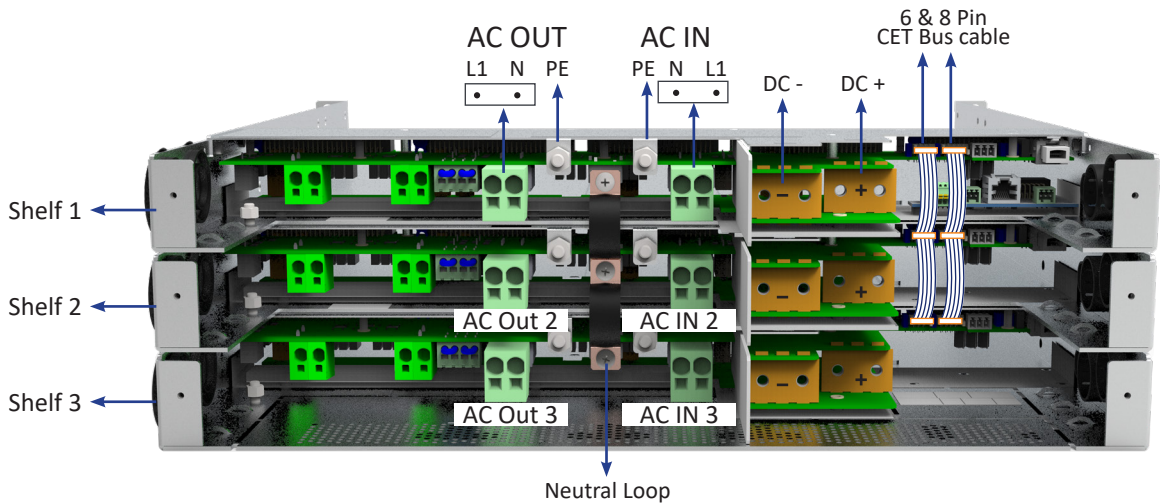

7.4.5.1 Three Phase Configuration with Inview Slot, S or X

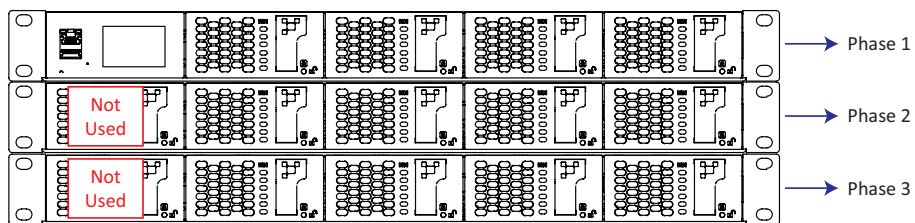

Three phase with Inview Slot - 12 kVA

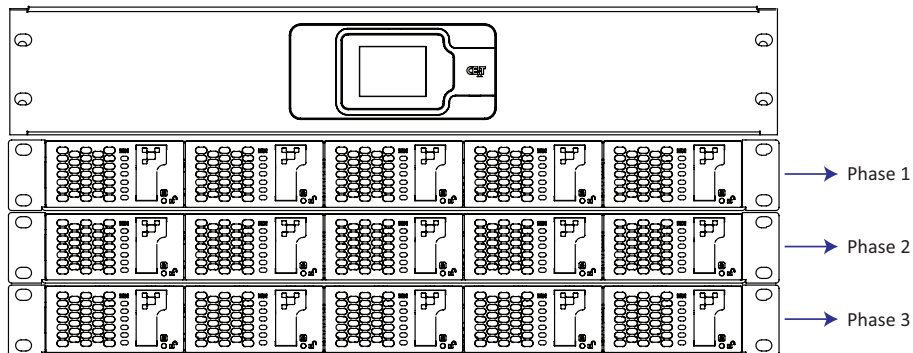

Three phase with Inview S - 15 kVA

7.4.6 AC Input and Output Connections

WARNING !!!

Recommendation of IEC 60364 4. 43

431.3 Disconnection and reconnection of the neutral conductor in multi-phase systems

Where disconnection of the neutral conductor is required, disconnection and reconnection shall be such that the neutral conductor shall not be disconnected before the line conductors and shall be reconnected at the same time as or before the line conductors.

RCD Recommendation

This equipment contains an EMI/EMC filter, which generates a leakage current below 3.5 mA per converter in conformity with the UL1778 safety standard. If an RCD device needs to be installed, it should be placed at the AC output of the equipment.

WARNING !!!

Input Neutral is required to operate the Converter, UPS

In TN-S System no 4 pole input switch or circuit breaker shall be used. If you have to use 4 pole protective device, be aware that the neutral against the ground is floating. The converter, UPS will operate without problem but you may infringe the local regulation.

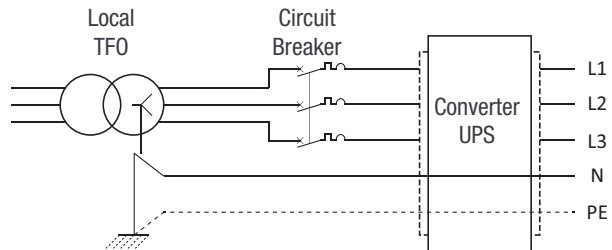

Model	Configuration	Maximum Capacity	Current @ 120 Vac	MCB per Shelf	Cable Minimum*
S71A33E0004SN000N001	Single-Phase 2 Wires (L-N)	4 kVA / 3.2 kW	37 A	50 A	4 AWG
S71A33E0005SN000W001		5 kVA / 4 kW	47 A	60 A	4 AWG
S71A63E0004SN000N001	Split-Phase 3 Wires (L1-L2-N)	4 kVA / 3.2 kW	19 A	25 A	10 AWG
S71A63E0008SN000N001		8 kVA / 6.4 kW	37 A	50 A	4 AWG
S71A63E0010SN000W001		10 kVA / 8 kW	47 A	60 A	4 AWG
S71A53E0012SN000N001	Three-Phase 4 Wires (L1-L2-L3-N)	12 kVA / 9.6 kW	37 A	50 A	4 AWG
S71A53E0015SN000W001		15 kVA / 12 kW	47 A	60 A	4 AWG

* One conductor / pole - 90°C

Note:

- The Icc value measured as 60 Arms per shelf with five modules.
- The current values are calculated based on correction factor of 75% with respect to ambient temperature of 40°C.
- EUT is suitable for Installation as part of Common Bonding Network (CBN) OR Isolated Bonding Network (IBN).

7.4.7 DC Connection

- One (1) common DC connection.
- Two holes of 1/4" hole with 0.75" between centre.
- It is mandatory to use only C-UL-US, or CSA listed Cable Lugs (Panduit: LCD2-14B-Q). Fix the lug with Pan Head 1/4-20 inch screw with torque 5.7 to 8.3 ft-lb

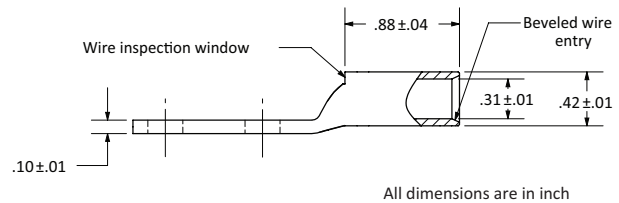
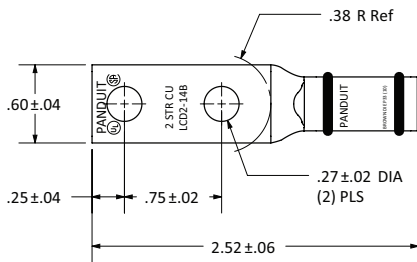

Model	Configuration	Maximum Capacity	Current @ 48 Vdc	MCB per Shelf	Cable Minimum
S71A33E0004SN000N001	Single-Phase 2 Wires (L-N)	4 kVA / 3.2 kW	74 A	100 A	3 AWG*
S71A33E0005SN000W001		5 kVA / 4 kW	93 A	125 A	2 AWG*
S71A63E0004SN000N001	Split-Phase 3 Wires (L1-L2-N)	4 kVA / 3.2 kW	74 A	100 A	3 AWG*
S71A63E0008SN000N001		8 kVA / 6.4 kW	2 x 74 A	2 x 100 A	3 AWG**
S71A63E0010SN000W001		10 kVA / 8 kW	2 x 93 A	2 x 125 A	2 AWG**
S71A53E0012SN000N001	Three-Phase 4 Wires (L1-L2-L3-N)	12 kVA / 9.6 kW	3 x 74 A	3 x 100 A	3 AWG**
S71A53E0015SN000W001		15 kVA / 12 kW	3 x 93 A	3 x 125 A	2 AWG*

* One conductor / pole - 90°C

** One conductor / pole - 90°C and One set of cables per shelf

Note:

- For each shelf, the DC breaker should be a separate branch protection (MCB) to distribute the DC from a Common Battery / Common DC BUS.
- The Inner hole diameter of the DC lug (two holes) should be 1/4", and it is recommended to use only with the supplied screws.
- EUT is suitable for Isolated DC Return (DC-I) or Common DC Return (DC-C).

7.4.8 Hardware Connections

Refer to the Inview User Manual for hardware connections between a Sierra shelf, an Inview controller and an optional Measure Box Battery.

7.4.9 Signalling

Each shelf comprises 8 and 6 pin connectors, Remote ON/OFF and a CE+T COM port for internal communication. The PCB at the bottom of the rear shelf is for Inview Slot. It can only be accessed if Inview Slot is connected to that shelf.

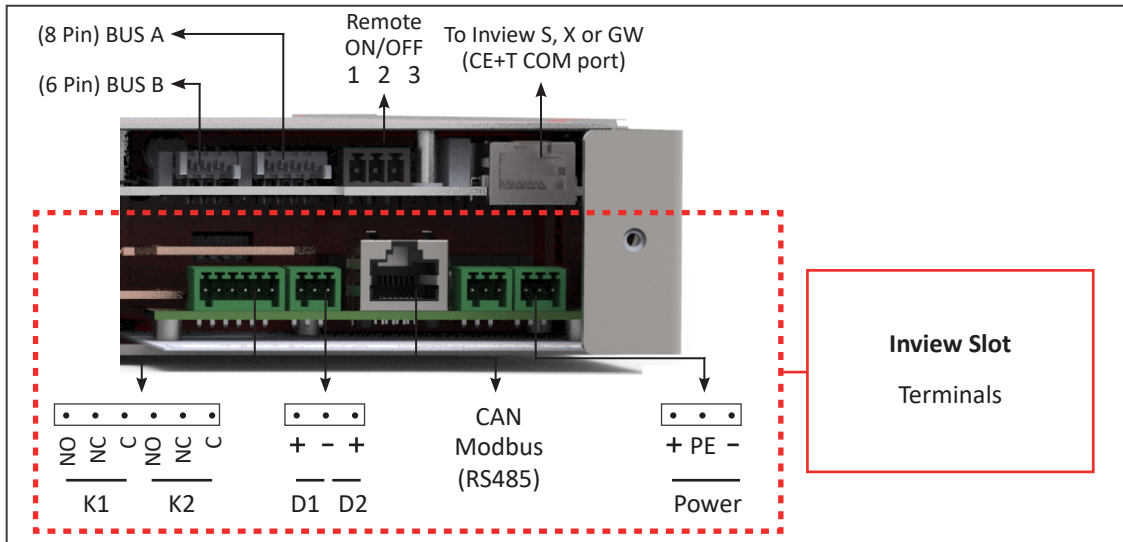

7.4.9.1 Remote ON/OFF

The shelf is by default equipped with a connection between pin 3 and 2. If remote ON/OFF is not used the strap shall remain in all connected shelves. Should the remote ON/OFF be used, all straps must be removed and in one (1) shelf replaced with a changeover contact or emergency button.

- The remote ON/OFF switch the output AC OFF.
- Input AC and input DC is not affected by the remote ON/OFF.
- The remote ON/OFF can be connected to any shelf.
- The remote ON/OFF requires changeover contacts, one input opens as the other close. If both transitions are not picked up the status is not changed.

Relay characteristics (Remote ON/OFF)

- Signal voltage +5 VDC (galvanic insulated)
- Max wire size 1 mm²

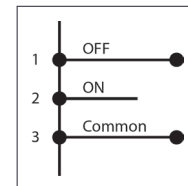

Functional table for remote ON/OFF function

#	Pin 1-3	Pin 2-3	Status	Indication
1	Open	Open	Normal operation	All (Green)
2	Closed	Open	OFF	AC output (OFF), AC Input (Green) & DC Input (Green)
3	Open	Closed	Normal operation	All (Green)
4	Closed	Closed	Normal operation	All (Green)

Warning! If remote ON/OFF is not used, pin 2 and 3 MUST be bridged together.

7.4.9.2 Internal bus (BUS A / BUS B)

- In a la carte system, Internal bus is pre installed and connected in series from the first shelf to last shelf.
- The internal bus comprises of 6 and 8 pin ribbon cables, and it is used to parallel if more than one shelf is present.
- If more than one shelf is ordered separately and installed in other cabinets, 6 and 8 pin connectors of each shelf should be looped with all the shelf using CAN bus cables.
- The internal bus connectors are sensitive and special caution should be taken during installation to keep them out of harms way.

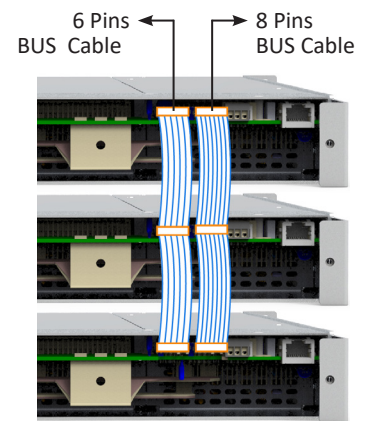

8. Replacement procedures

8.1 Module - Sierra 10

- The Sierra converter is hot swappable.
- When a new module is inserted in a live system it automatically adapts to a working set of parameters.
- When a new module is inserted in a live system it automatically assigns the next available address.

Caution: After removing a module from a slot in a live system, wait at least 60 seconds before inserting it into another slot; ensure that the LEDs are off and the fan is completely stopped.

8.1.1 Removal

Caution: When one or several converter modules is/are removed, possible to access the live parts. So, replace the module(s) with dummy modules without delay.

1. Insert a soft edged pin into the hole to unlock the latch. (Hole diameter is 3 mm)
2. Push the pin and simultaneously pull the module using front handle.
3. Remove the module from shelf and replace with a new module or dummy cover.

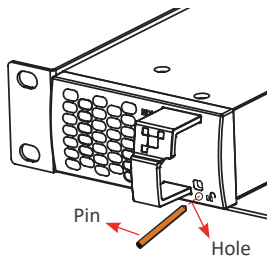

Insert the pin into the hole

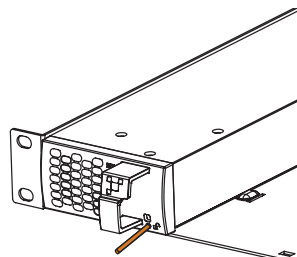

Push the pin and pull the module

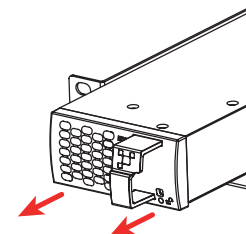

Remove the module from shelf

8.1.2 Inserting

1. Check module compatibility (DC Voltage!).
2. Place the module and slide into the shelf.
3. Push the module firmly using the front handle, until the module rear is connected correctly with shelf.
4. Make sure the bottom latch in the module is locked in the shelf.
5. The module will start up and take the first address available on the bus.

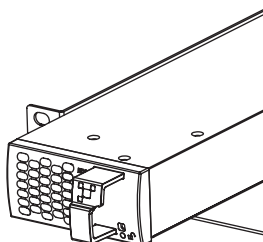

Place the module & slide into the shelf

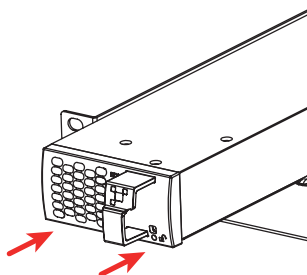

Push firmly until module is engaged

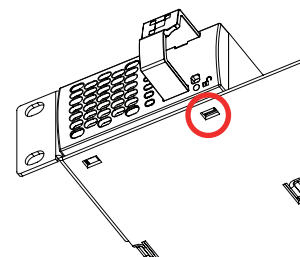

Make sure the latch is locked in the shelf

8.2 Controller - Inview Slot

8.2.1 Removal

1. Insert a soft edged pin into the hole to unlock the latch. (Hole diameter is 3 mm)
2. Gently push and press down the pin to unlock the latch and then remove the controller.

Warning: while removing the controller from the shelf, hold the top and bottom part of front plastic. Do not press on the touch screen.

3. Remove the controller from shelf and replace with a new unit or dummy cover.

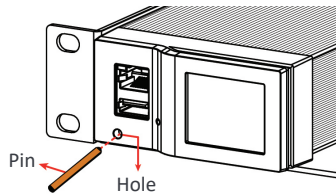

Insert the pin into the hole

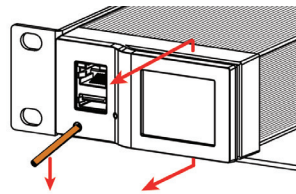

Push and press down the pin, and pull the unit

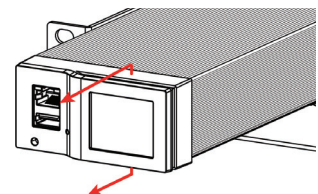

Remove the module from shelf

8.2.2 Inserting

1. Place the Inview Slot and slide into the shelf.
2. Push the unit firmly until the controller rear part is engaged correctly with shelf.

Warning: while inserting the controller into the shelf, push on the left side (ETH and USB port) of the controller. Do not press on the touch screen.

3. Make sure the latch is locked in the shelf.
4. The controller begins to start up and read the parameters from modules in the live system.

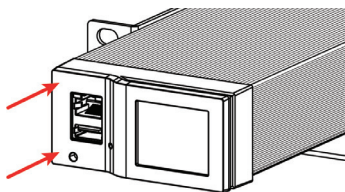

Place the module & slide into the shelf

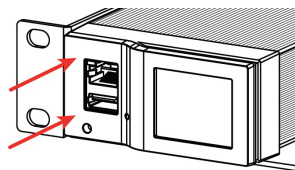

Push firmly until unit is engaged

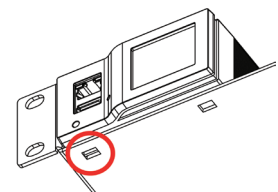

Make sure the latch is locked in the shelf

9. Manual By-Pass (Optional)

Manual By-Pass has to be operated by trained people only.

When system is in manual by-pass the load is subjected to mains voltage without active filtering. Output alarm is activated when system is in manual by-pass.

The Manual By-Pass cannot be operated remotely.

The Manual By-Pass can be integrated into the CE+T cabinet if requested at time of order. A Manual By-Pass purchased separately must comply with the instructions within section 9.2, page 30.

9.1 Pre-requisites

Commercial AC power must be present, and the converter must be synchronized with it, before operating MBP. The upstream commercial breaker must be correctly sized to accept the overload, and if the AC is supplied by a Gen-set, the minimal required power will be twice the nominal power of the converter.

The converter may be overloaded during the MBP procedure, depending on voltage network and output. Converter voltage setting: To reduce the impact of an overload, the converter power and current will be reduced from 150% to nominal value.

The by-pass switch disconnects all AC voltage on the shelves but has no effect on the DC feeding the converter and the remote alarm terminal.

It is requested in order to reduce the inrush current during manual by pass operation to adjust the converter AC output voltage to the same value as AC input voltage. If the difference between AC input and AC output voltage exceed 5 Vac, there is a risk of shutdown of converter due to high inrush current during the return to normal operation from Manual By Pass engaged.

9.2 MBP Auxiliary connection

If manual by pass (Single rotary switch) is installed in the system and its auxiliary should be wired as per the following:

Note: The below connection is for a sub-rack system, and auxiliary (Aux) number varies depending upon the MBP switch. So it is recommended to refer the technical sheet received along with the system.

- Connect Aux3 of MBP to Digital Input 01 of the controller. So that the controller gets information when MBP is engaged (The digital input terminal of Inview Slot is present at rear side of the shelf).
- Connect Aux1 and Aux2 of MBP to Remote ON/OFF terminal in the shelf where controller is installed.

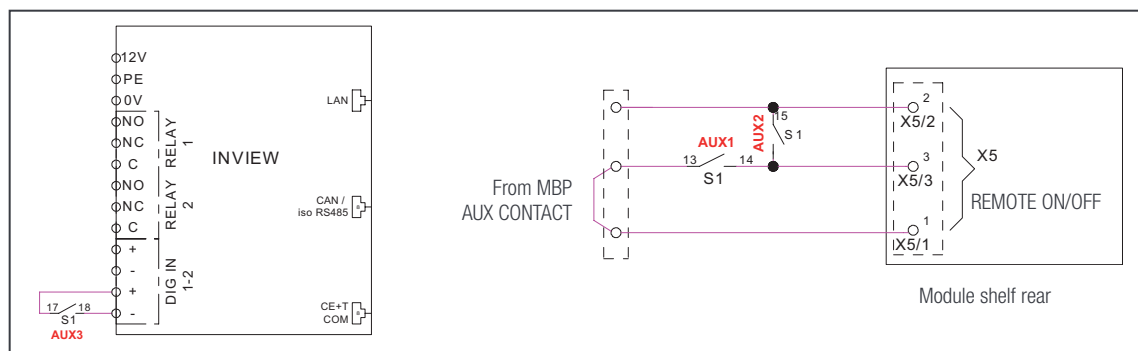

MBP auxiliary connection in Inview S

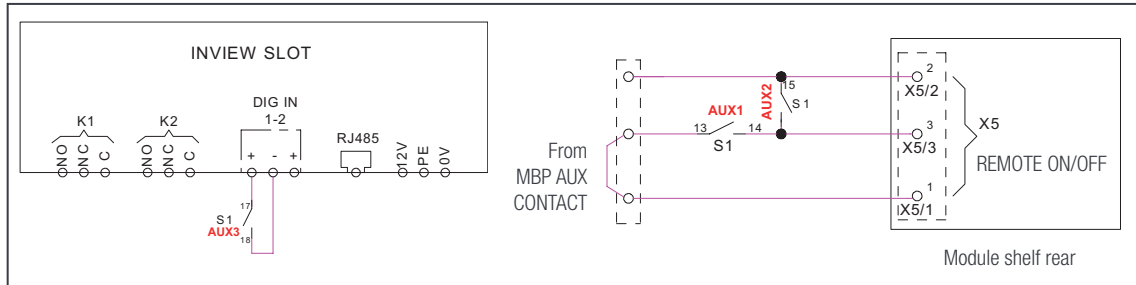

MBP auxiliary connection in Inview Slot

The Digital Input Mode must configure as below through Inview web Interface:

- In Advanced View, go to [Site > Configuration > Digital Input > D1 > CF501](#) and select “[convs1_ManulByPass](#)”

9.3 Manual By-Pass Operation

Manual Bypass operation creates a bypass from mains input via output AC distribution. Converter modules are bypassed and possible to disconnect without impacting the load.

Manual By-Pass operation is “Make before Break” logic.

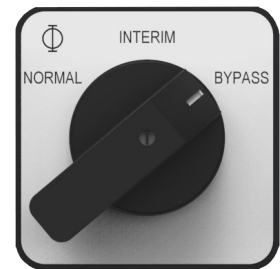

9.3.1 Normal to By-pass (Engage MBP)

1. Rotate the MBP Switch (S1) from **NORMAL** to **BYPASS**. **(Do not stop at INTERIM Position)**
2. Switch OFF the DC power and/or disconnect batteries.

Manual By-Pass puts the module in the OFF state but does not disconnect the DC. Make sure DC is disconnected before any intervention inside the system.

Warning: Risk of electric shock. Power will be available at AC Input terminal, AC Output terminal, DC Input terminal, and Surge Arresters.

9.3.2 By-pass to Normal (Disengage MBP)

1. Switch ON the DC power and/or connect batteries, and wait for module DC IN LED to turn green.
2. Rotate the MBP Switch (S1) from **BYPASS** to **INTERIM**.
(Wait until the modules turn on and synchronized, approximately 30-60 seconds).
3. Rotate the MBP Switch (S1) from **INTERIM** to **NORMAL**.

Warning: If ATS (Automatic Transfer Switch) is installed upstream to select AC source. Make sure that the ATS switch does not allow transfer between AC source out of sync. The maximum allowed phase shift is 10°.

10. Finishing

- Make sure that the sub-rack/cabinet is properly fixed to the cabinet/floor.
- Make sure that the sub-rack/cabinet is connected to Ground.
- Make sure that all DC and AC input breakers are switched OFF.
- Make sure that all cables are according to recommendations and local regulations.
- Make sure that all cables are strained relieved.
- Make sure that all breakers are according to recommendation and local regulations.
- Make sure that DC polarity is according to marking.
- Re tighten all electrical terminations.
- Make sure that no converter/controller positions are left open.
- Cover empty converter positions with dummy cover.
- Make sure that the Remote ON/OFF is appropriately wired according to local regulations.
- Make sure that the point of AC supply meets local regulations.

11. Commissioning

The DC breaker is a protection device. Modules are plugged in a system and DC breaker is then engaged. Please make sure the corresponding DC breaker is engaged in the ON position. Failure to observe this rules will result not to have all module operating when running on DC and have module failure when AC input recover from fault condition.

Installation and commissioning must be done and conducted by trained people fully authorized to act on installation.

It is prohibited to perform any isolation test without instruction from manufacturer.

Equipments are not covered by warranty if procedures are not respected.

The default frequency of Sierra 10 - 48/120 modules is 60 Hz. If the frequency of the grid is 50 Hz, the Sierra 10 - 48/120 modules does not start automatically. In such cases, use a battery or an external auxiliary power supply converter (AC to DC) to power up the Inview and change the default frequency of the Sierra 10 - 48/120 modules through Inview.

11.1 Check list

DATA	
Date	
Performed by	
Site	
System serial number	
Module serial numbers	
Inview Serial number	
ACTION	OK/ N.OK
Unplug all converters except one converter per phase (Just pull off the converter from the shelf, to interrupt electrical contacts)	
Check the commercial AC before closing the AC input breaker.	
Switch ON the commercial AC	
Check if converters are working (Green led)	
Check the DC power supply and switch ON the DC breakers	
Plug in all converters one by one	
Check output voltage (on bulk output or on breaker)	
Check if converters are working properly	
Check if system has no alarm (Disable the alarm if any)	
Read configuration file and review all parameters. Some parameters must be adapted according to the site (LVD, load on AC, AC threshold level)	
Switch OFF ACin and check if system is working on DC	
Switch ON ACin and check if system correctly transferred load on AC	
Switch OFF system and start on AC only	
Switch OFF system and start on DC only	
Check if display working properly (Inview)	
Check if TCPIP working properly (if this option is present)	
Test on load (if available)	
ALARM	
Switch ON AC input and DC input and check that no alarm are present	
Pull out one converter and check alarm according to redundancy	
Pull out two converters and check alarm according to redundancy	
Switch OFF AC input (commercial power failure) and check the alarm according to the configuration	
Switch OFF DC input (DC power failure) and check that the alarm according to the configuration	
Check the different digital input according to the configuration (when used)	

12. Trouble Shooting and Defective Situations Fixing

12.1 Trouble Shooting

Converter module does not power up:	Check AC input present and in range (AC breakers)
	Check DC input present and in range (DC breakers)
	Check that the converter is properly inserted
	Remove converter to verify that slot is not damaged, check connectors
	Check that module(s) is (are) in OFF state
	Check for loose terminations
	After a long storage period without power, the internal capacitors may be fully discharged. If the unit does not start at power-up, disconnect and reconnect the AC and/or DC power supply. Repeat 2 to 3 times.
Converter system does not start:	Check that Inview is present and properly connected
	Check remote ON/OFF terminal
	Check the configuration and setting
	Check threshold level
Converter only run on AC or DC:	Check AC input present and in range (AC breakers)
	Check DC input present and in range (DC breakers)
	Check the configuration and setting
	Check threshold level(s)
No output power	Check output breaker
All OK but I have alarm:	Check the type of event and log file in the controller
No alarm:	Check relay delay time of alarms in the controller
	Check configuration file

12.2 Defective Modules

- A repair request should follow the regular logistics chain:
End-user => Distributor => CE+T Power.
- Before returning a defective product, a RMA number must be requested through the <http://my.cet-power.com> extranet. Repair registering guidelines may be requested by email at tech.support@cetamerica.com.
- The RMA number should be mentioned on all shipping documents related to the repair.
- Be aware that products shipped back to CE+T Power without being registered first will not be treated with high priority.
- While returning the defective module, should mention all the details in the RMA document.

13. Maintenance

Maintenance shall only be performed by properly trained people.

13.1 Access Inview with Laptop

- Download system LOG FILE and save.
 - Analyze log file and correct errors.
- Download system CONFIGURATION FILE and save.
 - Check/correct configuration file according to operation conditions.
 - Check/correct alarm configuration.
- Check module internal temperature for deviation between modules.
 - Temperature deviation may indicate build up of dust. Clean the module by air suction blower or vacuum cleaner.
- Check module/system load.
- Check/Correct converter mapping (DC group/AC group/ Address).
- Change configuration file to validate that system operates on both supply sources.
- Check outgoing alarm, consult configuration file what actions will generate alarm.

13.2 Manual check

- Validate input voltage (AC input, DC input, AC output) with multi-meter.
- Replace dust filter.

13.3 Optional

- With an infrared camera check termination hot spots.
 - Tighten terminations.

14. Service

For Service

- Check Service Level Agreement (SLA) of your vendor. Most of the time they provide assistance on call with integrated service. If such SLA is in place, you must call their assistance first.
- If your vendor doesn't provide such assistance (*) you may contact CE+T by calling toll free Number **+1-855-669 - 4627(**)** or tech.support@cetamerica.com

Normal service hours are 8:00 AM to 5:00 PM Eastern Time, Monday through Friday, except closing periods for holidays or inclement weather.

Critical/emergency conditions by calling **+1-855-669-4627** or emailing tech.support@cetamerica.com

(*) CE+T will redirect your call to your vendor if he has such SLA in place.

(**) Valid in USA and Canada only.

(***) Messages that are not Major Incident or Emergency will be served at the next scheduled working day.

15. Appendix

15.1 Sierra 10 - 48/120 - Dimensions

15.1.1 Module

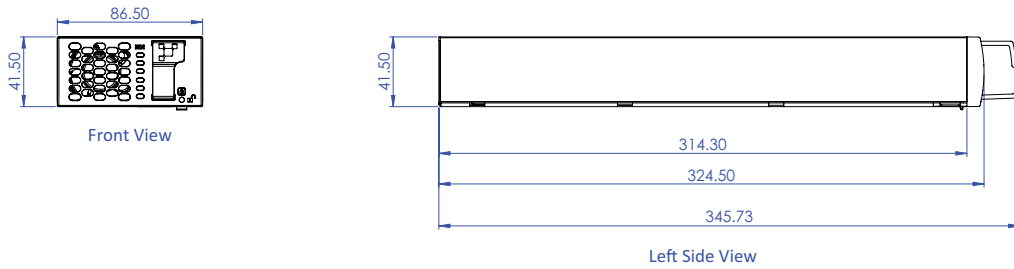

15.1.2 Shelf

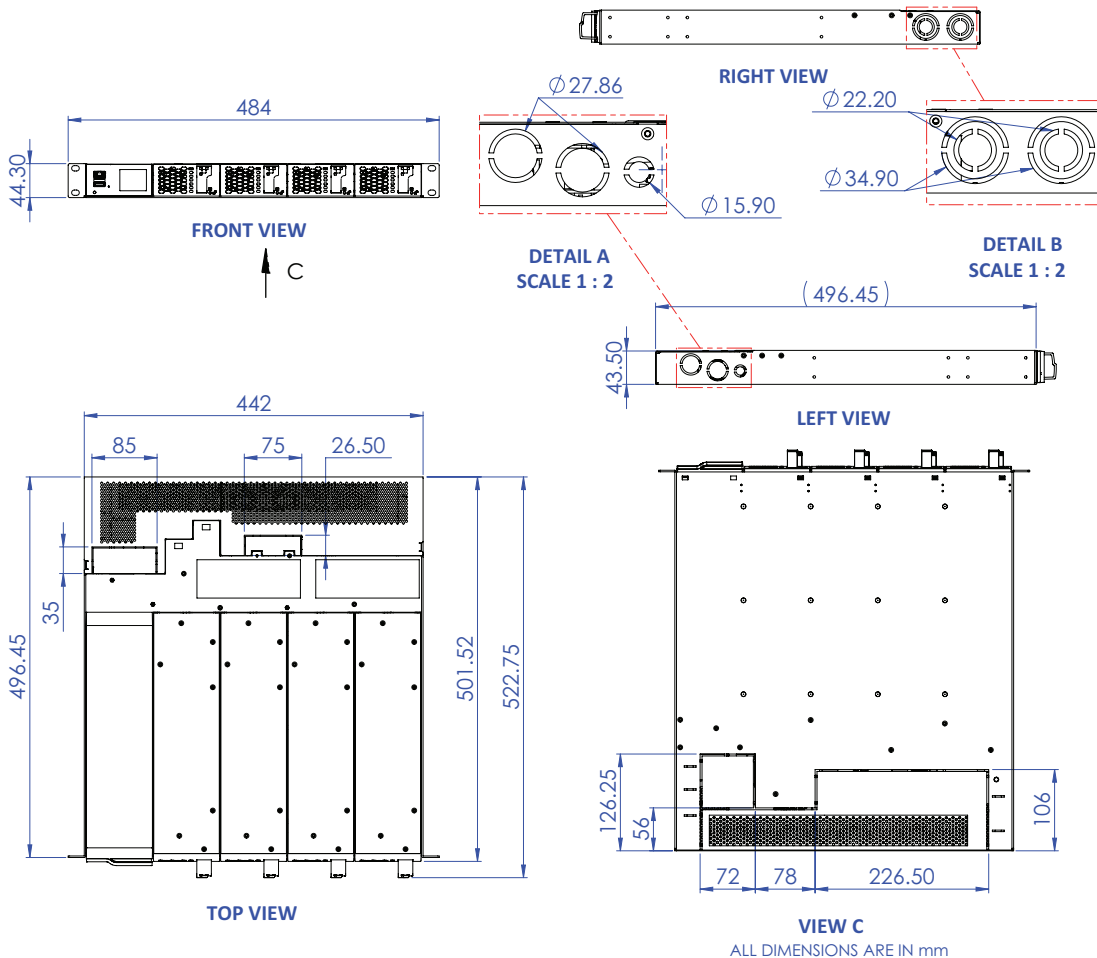

15.2 System Connections and Wiring diagrams

15.2.1 Single phase (L-N)

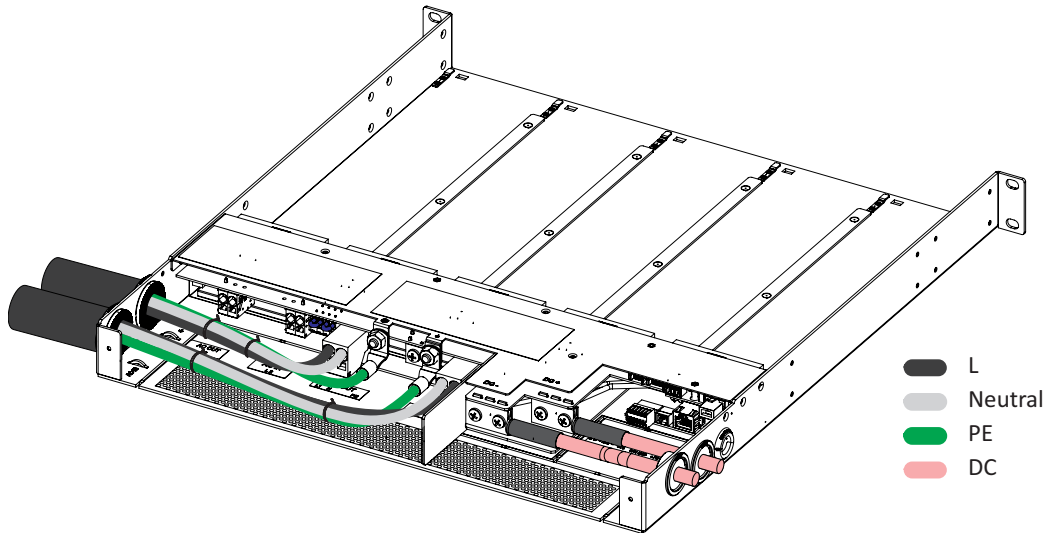

Single phase - Cable connections

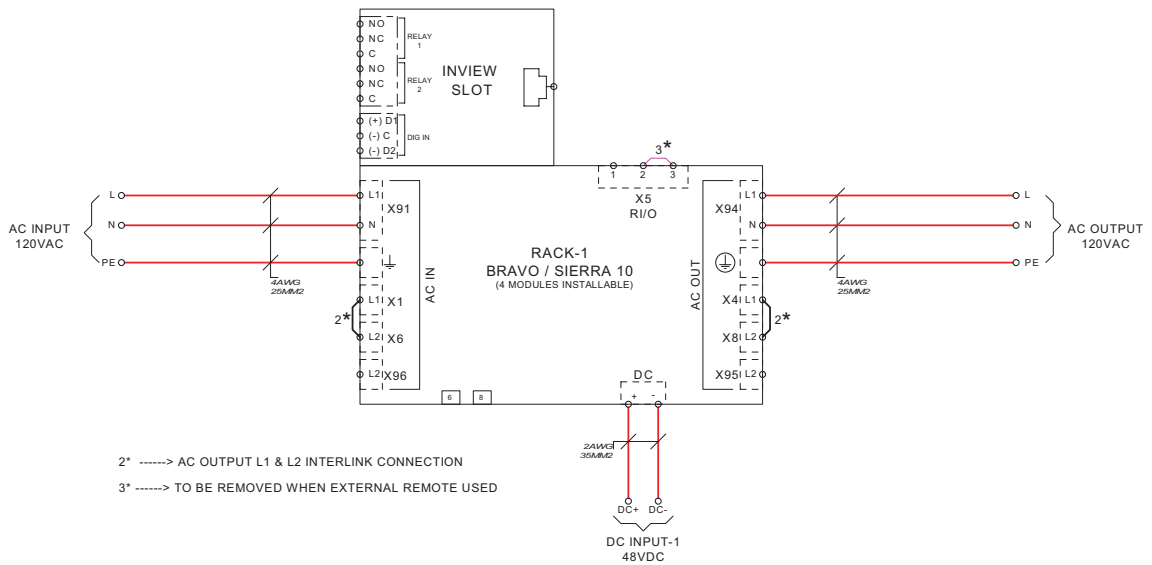

Single phase - Wiring diagram

15.2.2 Single phase (L-N) - REG

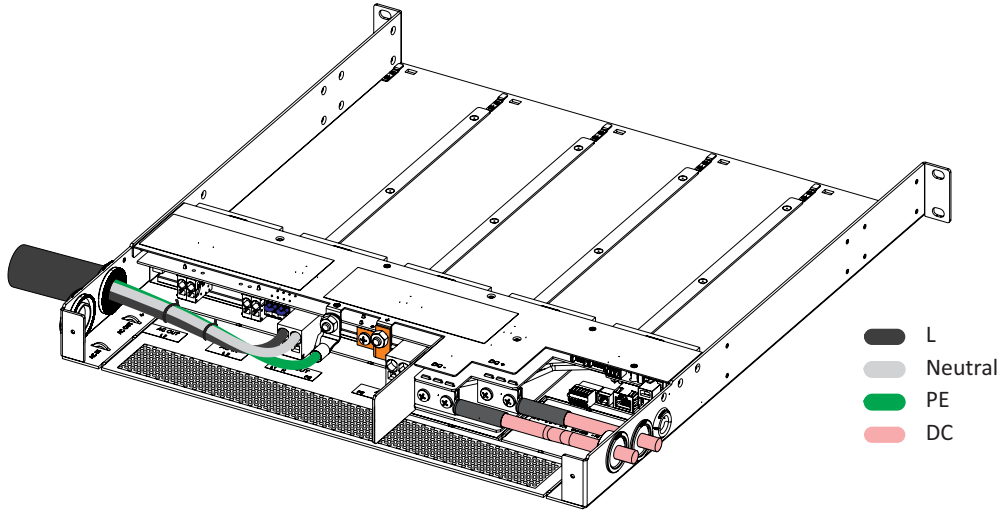

Single phase - REG- Cable connections

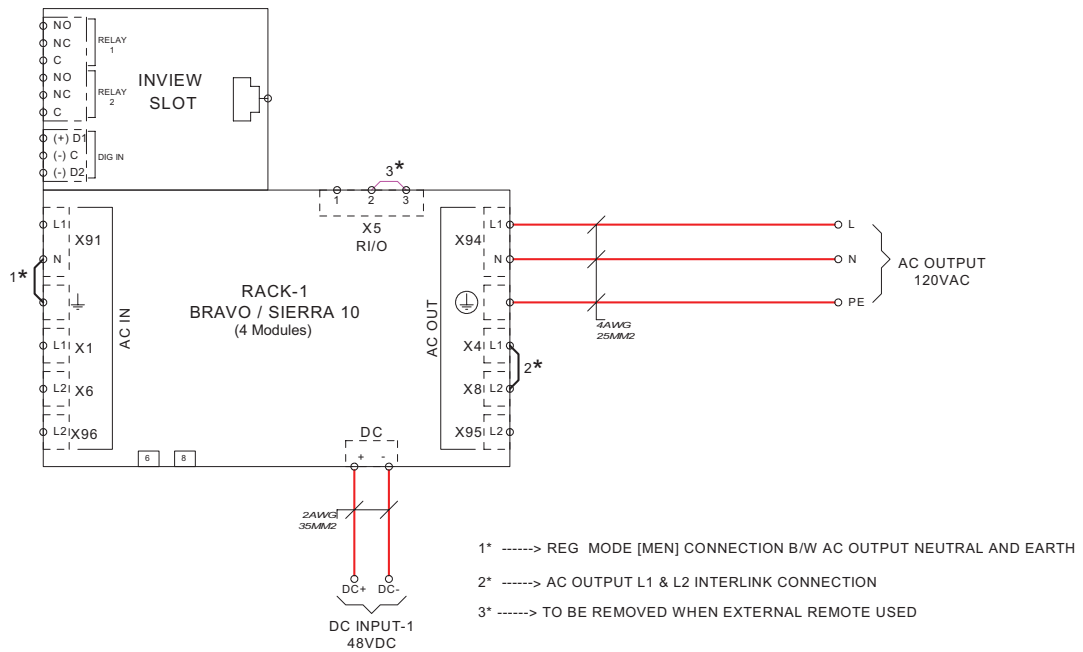

Single phase - REG - Wiring diagram

15.2.3 Single shelf - Split phase (L1-L2-N)

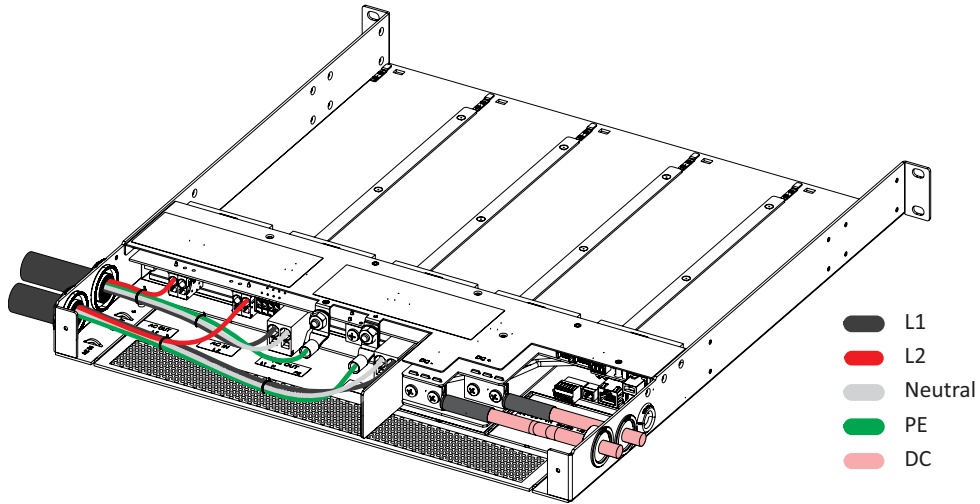

Split phase - Single shelf - Cable connections

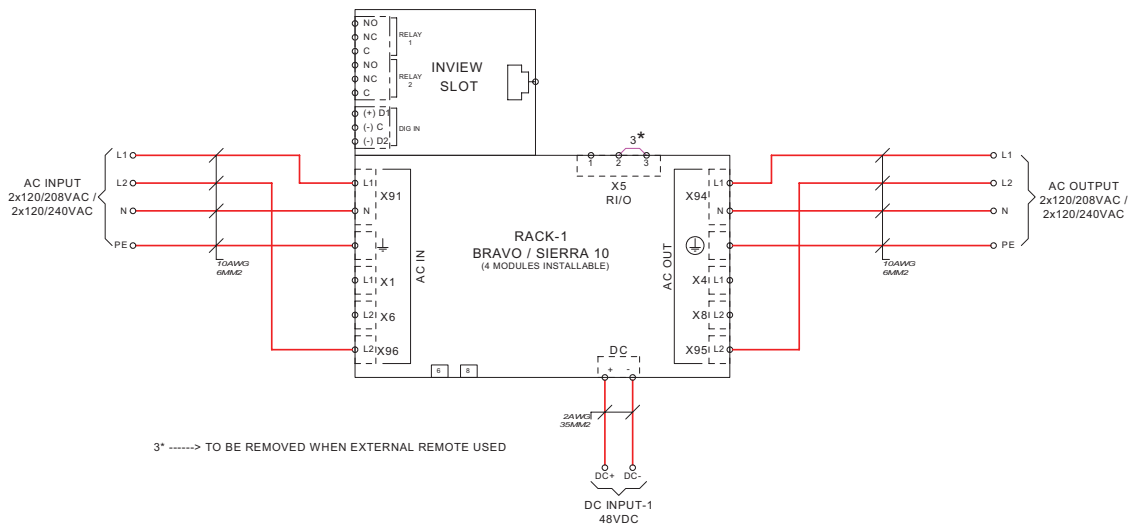

Split phase - Single shelf - Wiring diagram

15.2.4 Single shelf - Split phase (L1-L2-N) - REG

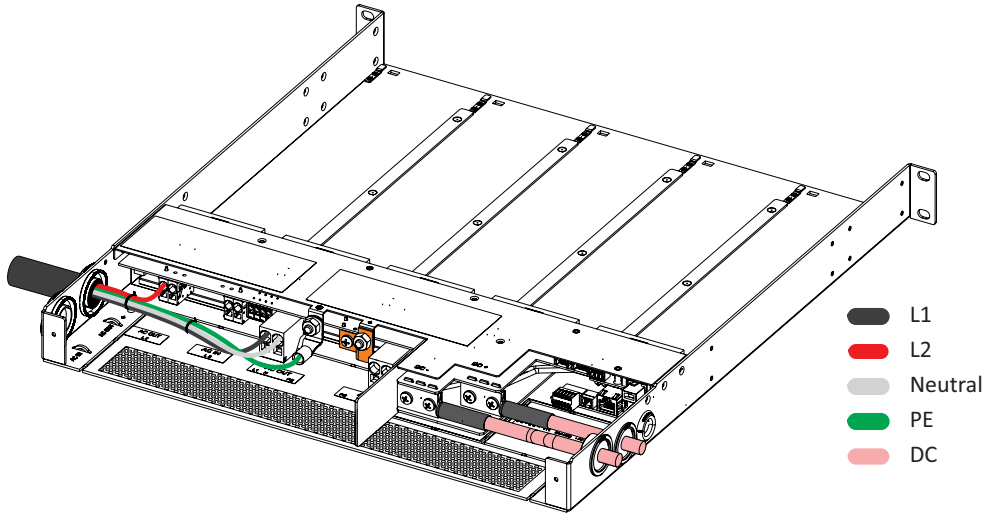

Single shelf - Split phase - REG - Cable connections

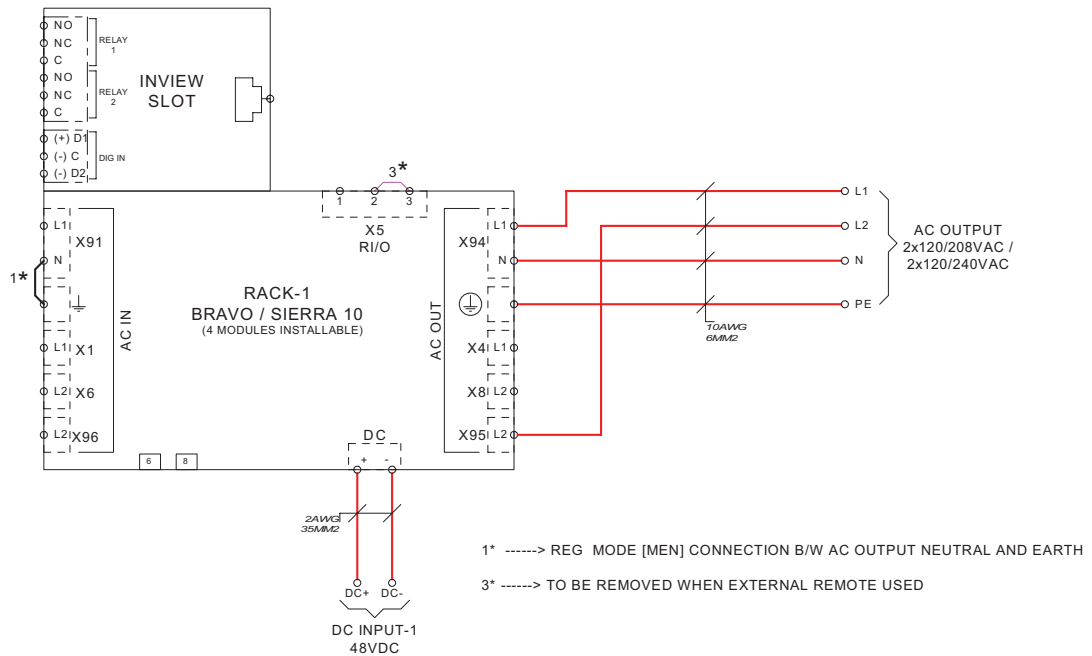

Single shelf - Split phase - REG - Wiring diagram

15.2.5 Two shelves - Split phase (L1-L2-N)

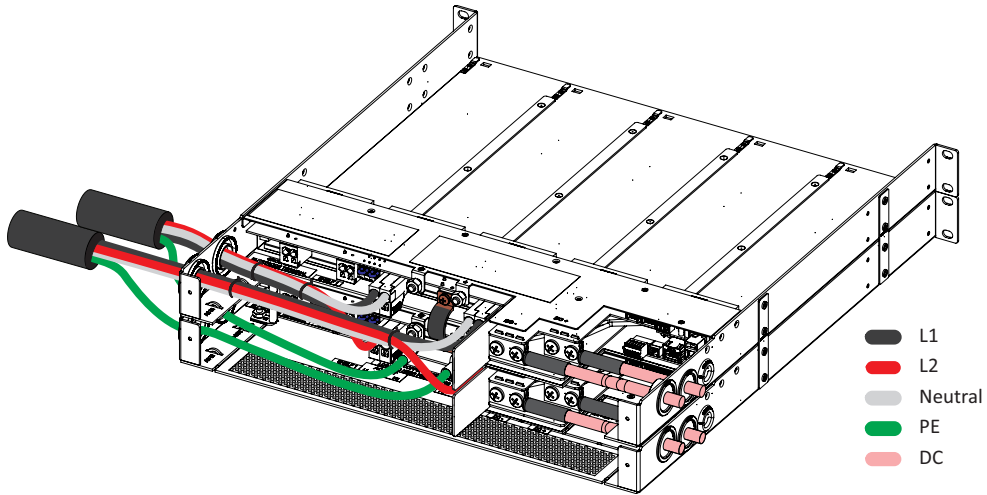

Split phase - Cable connections

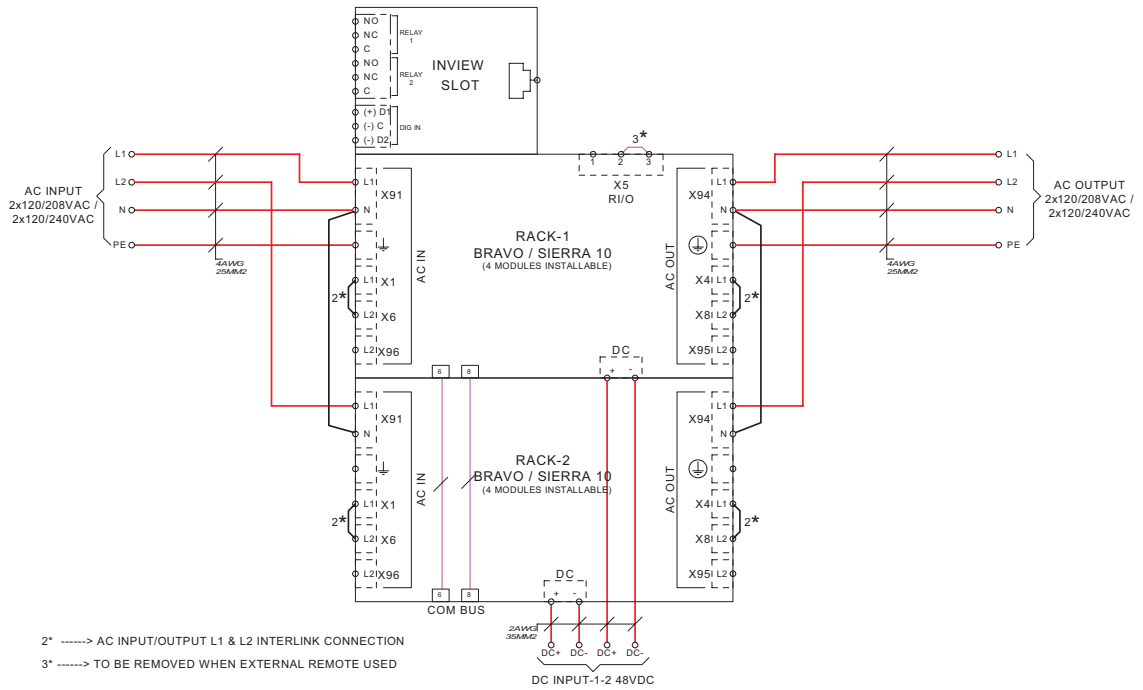

Split phase - Wiring diagram

15.2.6 Two shelves - Split phase (L1-L2-N) - REG

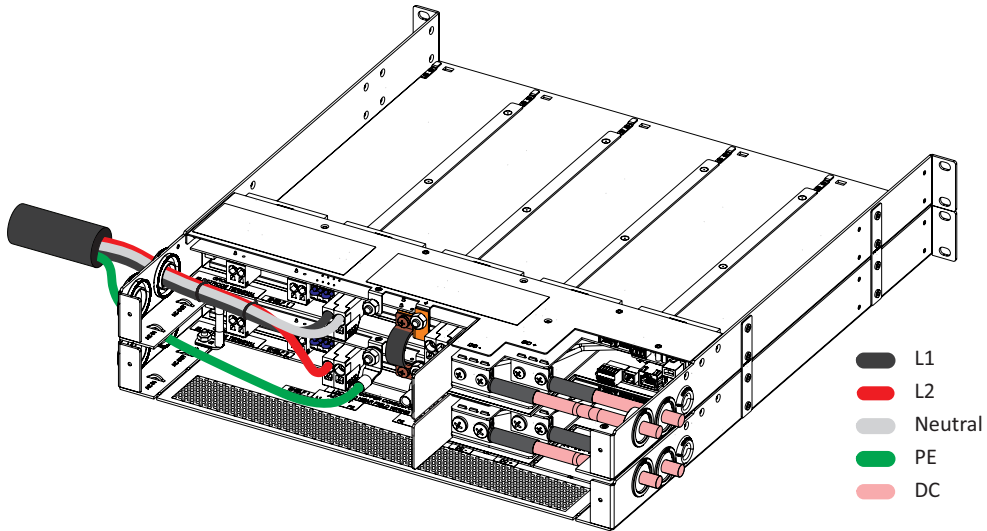

Split phase - REG - Cable connections

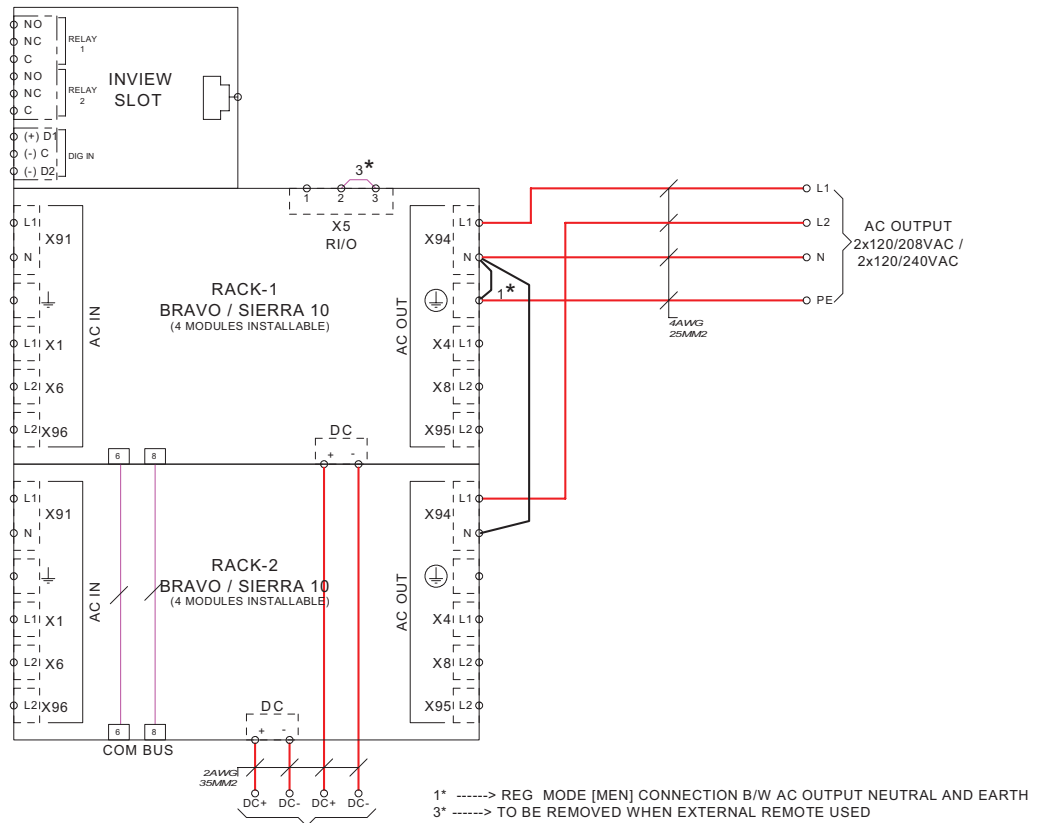

Split phase - REG - Wiring diagram

15.2.7 Three phase (L1-L2-L3-N)

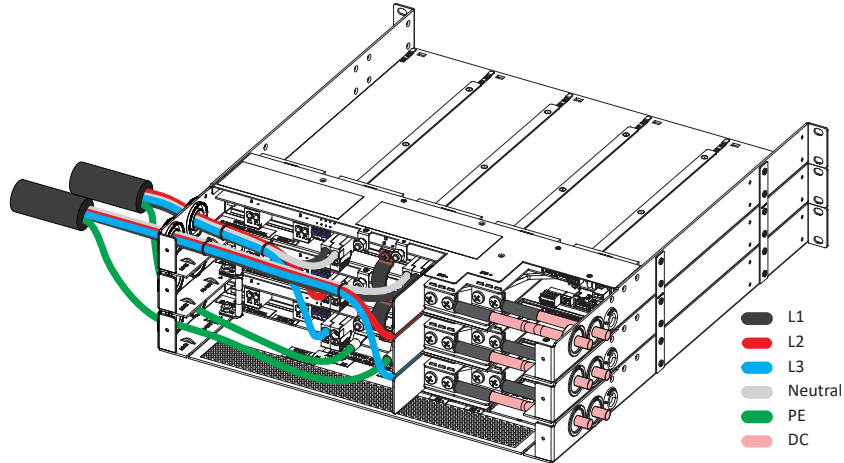

Three phase - Cable connections

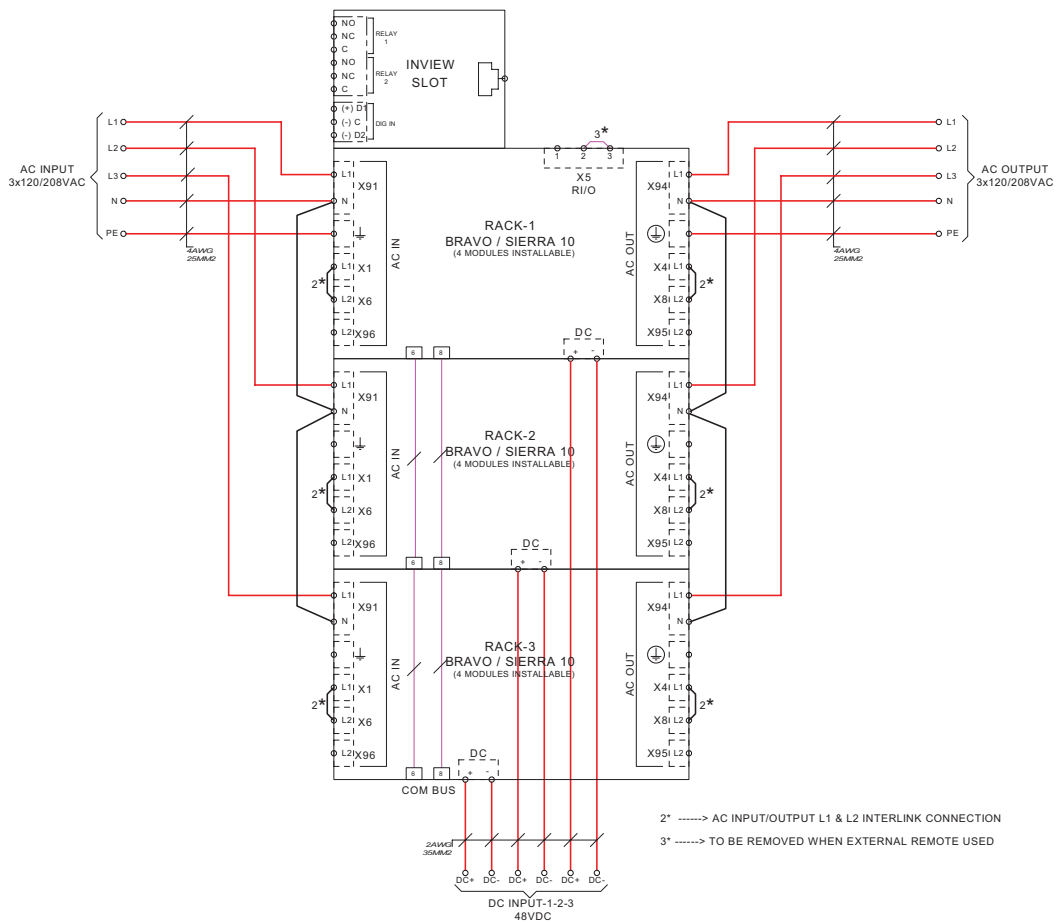

Three phase - Wiring diagram

15.2.8 Three phase (L1-L2-L3-N) - REG

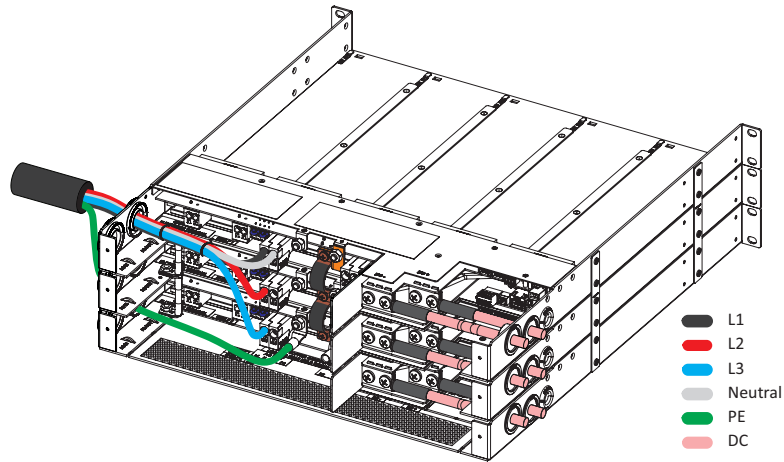

Three phase - REG - Cable connections

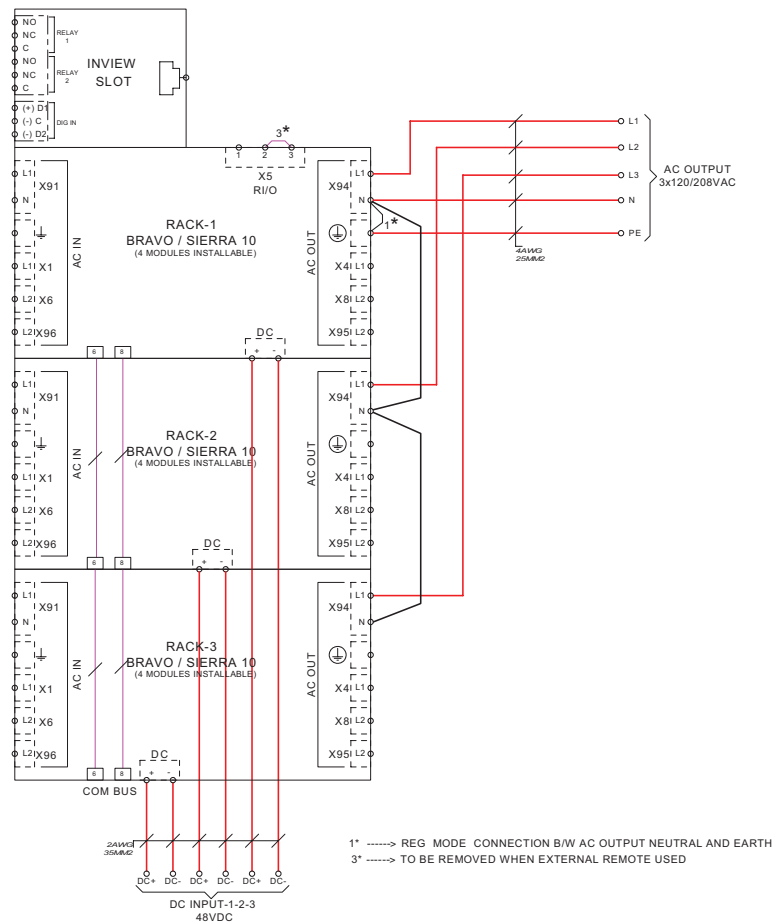

Three phase - REG - Wiring diagram

15.3 Modules - Parameter List

With Inview, you can access the modules' parameter list and descriptions. Refer to the Inview and Inview GW user manuals to access the Inview web interface.

Inview Slot, S and X - <https://datasheet.cet-power.com/CET - Monitoring - User Manual - Inview - EN.pdf>

Inview GW - <https://datasheet.cet-power.com/CET - Monitoring - User Manual - Inview GW - EN.pdf>

If you want to have an overview of standard systems' parameters, you can also view the parameters in our Monitoring Emulator - <https://www.cet-power.com/en/monitoring-emulator/>.

Do not hesitate to use the help buttons to get more information about the parameters.

